

STATUS OF PYRO-PROCESS FUEL CYCLE TECHNOLOGY DEVELOPMENT AT CRIEPI

Takeshi Yokoo and Tadashi Inoue

Central Research Institute of Electric Power Industry, Japan

Abstract

Recent results of CRIEPI's pyro-process fuel cycle technology developments are reported. On the actinides deposition into liquid cadmium cathode, a series of experiments are conducted using a small scale electro-refiner of about a hundred grams actinides inventory. The suitable condition for co-deposition of U and TRUs is investigated, by varying Pu/U ratio in the salt from ∞ to 1.7. The design considerations to realise better yields in injection casting are clarified by conducting 20 kg/batch scale tests using U-Zr. Some studies on the oxide dross formation due to the reaction between the molten fuel and crucible coating or casting mold are also conducted. Actinides should be recovered from the dross to achieve a very high recovery ratio. It is shown that $ZnCl_4$ is capable of chlorinating these actinides oxide. The obtained actinides chloride can be recycled into the electro-refining process.

Introduction

CRIEPI has been working on the technology development for a P&T system that is based on pyro-process recycling of metal fuel fast reactors. [1] Recent efforts are concentrated on the R&Ds of main processes such as electro-refining and fuel fabrication, in pursuit of higher actinides recovery.

Figure 1. The Electro-refining process (500üÄ)

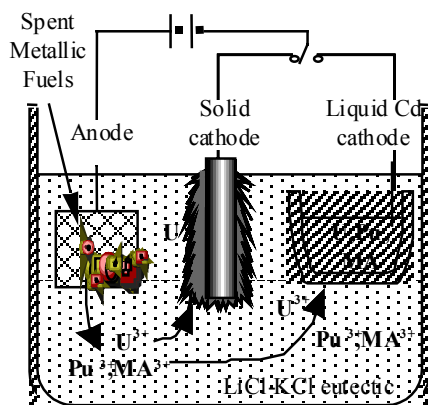

MA: minor actinides (Np, Am, Cm)

In the electro-refining process, chopped fuel pin segments are loaded into the anode basket and actinides are electro-transported to the cathode through the molten-salt bath (LiCl-KCl), as shown in Figure 1. It is suggested, based on large-scale experiments, that 10 kg or more U can be collected onto a solid cathode by an overnight electro-refiner operation. Anode/cathode module type electrode is being developed seeking much faster collecting rate. [2] To collect Pu, together with U and minor actinides (MAs), it is proposed to use liquid cadmium cathode, but R&D results are still limited and there is much to be learned before we can establish prototypic designs. In this paper, the results of small scale actinides electro-refining experiments are described. A small electro-refiner of about a hundred grams actinides (U, Pu, Am) inventory is used. And, as an effort to find suitable conditions for co-deposition of U and TRUs at a better current density, actinides are collected into liquid cadmium cathode varying Pu/U ratio in the salt from 12 to 1.7. This series of experiments are conducted as a joint programme with JAERI.

Thousands of metal fuel slugs were fabricated by injection casting at ANL for EBR-II. [3] In injection casting, molten fuel alloy is injected into quartz molds by de-pressurising/ pressurising the furnace, as shown in Figure 2. We have been conducting a series of 20 kg/batch scale tests using U-Zr, to clarify the design and operational considerations needed to achieve better yields. The oxide dross formation due to the reaction between the molten fuel and crucible coating or casting mold is also studied. The results of these tests are described in this paper. These studies are conducted as a part of the nuclear research programme of MEXT. [4]

In addition to injection casting, there can be many sources of actinides oxides, or oxychlorides formation in the actual pyro-process plant. The amount may become more than a per cent of the total mass flow. Actinides should be recovered from these oxides to achieve a high enough recovery ratio. Rather than reducing the actinides into metal, it is proposed to chlorinate them and bring the chloride back into the electro-refiner. ZnCl₄ is selected as the chlorination material and investigated experimentally, using U and Pu and oxide. [5]

Figure 2. Injection casting process

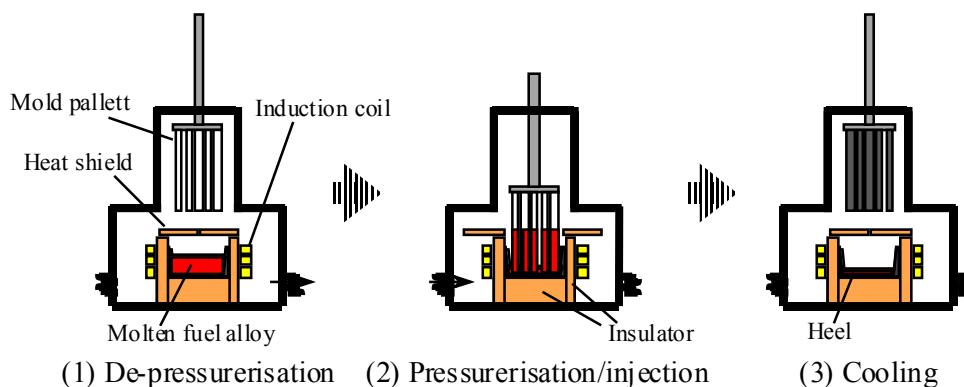

Electro-refining

Experimental

The electro-refining experiments are carried out at 500°C, in a high purity argon atmosphere glove box, where both oxygen and moisture levels are kept less than two ppm. Figure 3 shows the apparatus. The inner diameter and the depth of the steel container for the salt are 124 mm and 120 mm, respectively. The salt is LiCl-KCl eutectic and the amount of about 1 200 g is loaded, forming a layer of 60 mm depth. At the bottom of the container, about 1 400 g of liquid cadmium pool (16 mm depth) is placed, which has an actinides inventory of 2~3 weight per cent and acts as the anode. The cathode crucible shown in Figure 4 is made of aluminium nitride. Its inner wall is slightly tapered and the diameter is 40 mm at the bottom. It contains 120 g of liquid cadmium (12 mm depth). Salt, Cd pool and cathode Cd are stirred with AlN stirrer at 40 rpm.

Figure 3. Schematic view of electro-refining apparatus

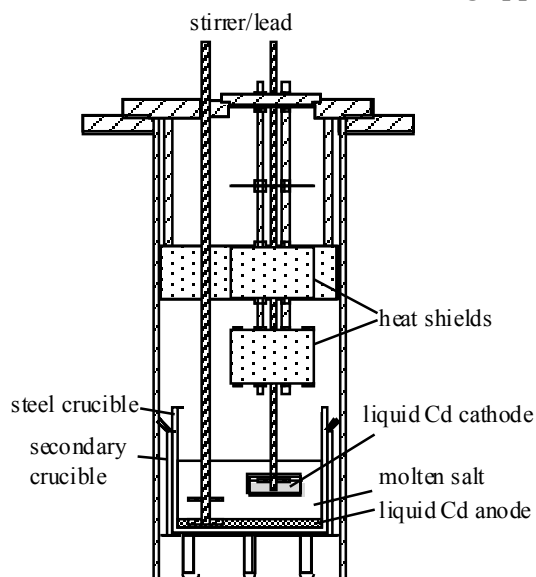

The Pu content in the salt at the initiation of each run is adjusted by either one of the following procedures. At the beginning of the experiment, PuN is put into the salt and converted to PuCl₃ by adding CdCl₂ ($2\text{PuN} + 3\text{CdCl}_2 \rightarrow 2\text{PuCl}_3 + 3\text{Cd} + \text{N}_2\uparrow$). Then some of the Pu is reduced from the salt into anode Cd pool by adding Cd-Li. When the Pu deposition into the Cd cathode is obtained, Pu is recycled by conducting anodic dissolution using the cathode Cd ingot as the anode. U is also recycled or added by anodic dissolution method. The Pu used in this experiment is reactor grade and has about 2% Am content due to the decay of ²⁴¹Pu. Each run is conducted at a constant current. The U and Pu concentration of the salt is analysed by ICP-AES and the cathode deposits are analysed by EPMA. Am is analysed by detecting the gamma emission with a germanium detector.

Results and discussions

A series of electro-deposition runs are conducted. Only Pu and associating Am are in the system at first, and U is added and increased gradually. The results are summarised in Table 1. The Pu content in the salt is set to be about 5 weight per cent throughout the series, due to the facility regulation on the Pu inventory. More than 10 weight per cent of actinides are successfully deposited in the cathode Cd in all the runs except LCC-25, which is conducted without cathode stirring and the resulted in some deposition outside the cathode Cd. These results suggest that the liquid cadmium cathode can be reasonably compact since actinides are collected into the cathode well exceeding the solubility limit. Plutonium and Am form MCd₆ type compound in the cathode after Pu has reached the solubility limit. The separation factor, Am/Pu, is found to be 0.7~0.8.

Figure 4. **Liquid Cd cathode crucible and stirrer**



Uranium can be collected together with Pu and Am. Although the actual situation during the operation is not fully understood yet, MCd₁₁ type compound and U are observed in the cathode ingot in addition to MCd₆, as shown in Figure 5. When the initial Pu content in the salt is well larger than U, i.e. Pu/U > 4.0, the separation factor (U/Pu) is 1~2. These results indicate that both U and Pu are continued to be collected past the solubility limit. In the case of LCC-33 where the initial Pu/U is < 2.0, however, the separation factor is 10.0. It is because only U is collected after the cathode cadmium is the cathode Cd is saturated, as shown in Figure 6. This result suggests that the balance between the deposition rate and the mixing of the cathode content should be carefully taken into account in the liquid cadmium cathode design. There may be a limit to the current density when the U content in the salt is large, even if a good cathode mixing is provided. Detailed investigations of the reactions that occur at the surface of the cathode cadmium, and the MCd_x compounds formation are needed to find the reasonably achievable collection rate.

Table 1. Results of liquid cadmium experiments

Test	Concentration in			Current (mA)	Ampere- hours (A-h)	Content in Cd		SF (U/Pu)	Current efficiency (%)	Comments
	Pu	U	Pu/U			Pu	U			
	(wt%)	(wt%)	ratio			(wt%)	(wt%)			
LCC-15	4.6	0	–	300-250	5.4	11.1	0	–	93.1	Am followed Pu in product. SF(Am/Pu)=0.74.
LCC-18	4.5	0	–	350-300	5.3	11.4	0	–	98.0	A larger impeller was employed.
LCC-20	4.4	0.36	12.2	300	5.3	9.1	1.3	1.6	92.0	The product ingot had a knob. MCd6 phase was observed.
LCC-23	5.0	0.67	7.4	300	5.3	9.3	1.8	1.3	92.8	Salt was distributed in the product ingot.
LCC-25	5.0	0.62	8.0	300	5.1	7.9	1.2	1.2	79.9	No stirring. Some deposit on the impeller.
LCC-28	4.7	1.1	4.4	300	5.3	8.6	3.4	1.7	93.3	MCd11 and MCd6 phases were observed. SF(Am/Pu)=0.78.
LCC-30	4.8	1.1	4.3	300-250	5.3	7.1	3.3	2.0	93.2	The crucible was broken when the product ingot was removed.
LCC-33	4.5	2.6	1.7	300	5.2	1.8	9.0	10.0	99.0	After HM in the cathode Cd exceeded the solubility limit, only U was collected.

Figure 5. Backscattering electron image of a liquid cadmium cathode ingot

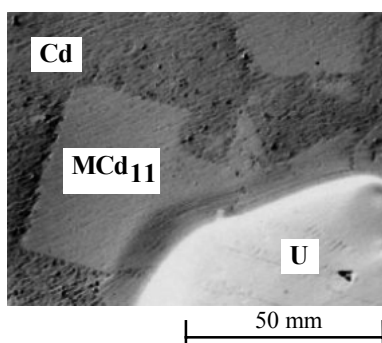

Injection casting

Casting equipment

The test equipment is designed and fabricated based on the information of the injection casting furnace design developed by ANL for the Fuel Cycle Facility (FCF). As shown in Figure 7, it has about 700 mm outer diameter and 2 700 mm height. The crucible is made of graphite and can be heated up to 1 580°C with a no water cooling type induction coil of 30 kW output. The inner wall of the crucible is coated with Y₂O₃ powder before each operation to prevent the reaction between molten

fuel alloy and the crucible. The used material is U-10wt%Zr and the maximum batch size is about 20 kg. To simulate the prototypic geometry specifications for commercial fuel fabrication, quartz mold of 6 mm inner diameter and 500 mm length is used. The inner wall of the mold is coated with ZrO₂ powder, and 50~100 molds are set on the pallet for one batch. Both ends are cut after casting and slugs of 400 mm are obtained for the examination. For the composition measurement, samples are taken and ICP-MS is carried out.

Figure 6. History of Pu and U deposition in cathode

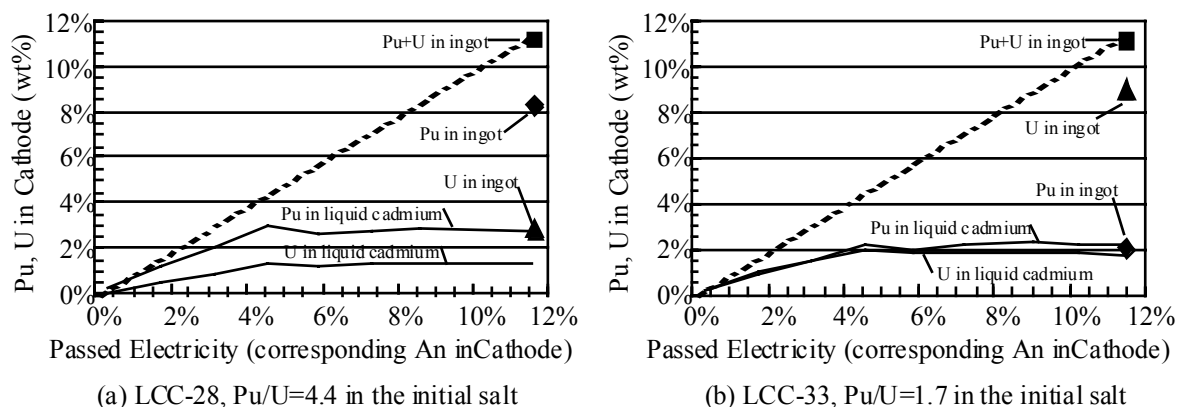
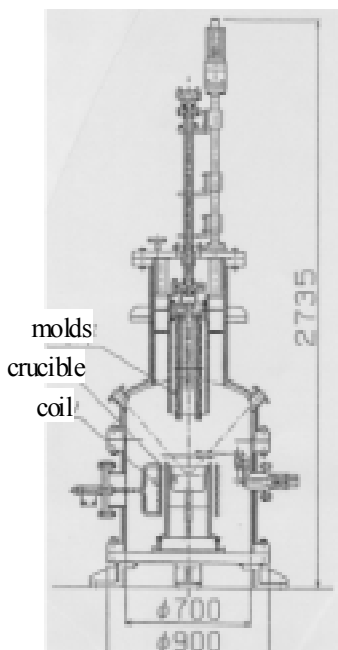

Figure 7. Schematic view of the injection casting equipment



Results and discussions

As summarised in Table 2, six runs are conducted. Loading patterns of the materials, heating time for the alloy and molds, pressurisation rate, and other parameters are adjusted to obtain good products. As the results, it is confirmed that most of the following performance parameters can be satisfied, even when the heel (left over alloy from the casting) from previous runs is used as a part of the feed material.

Table 2. Summary of injection casting runs

Test	objective	batch size (kg)	mold dia. (mm)
Run1	Induction coil is tested	12	6.0 ± 0.2
Run2	Design parameters check.		6.0 ± 0.1
Run3	Heel is fed.		
Run4	Larger batch test.	20	6.0 +0.0, -0.1
Run5	Heel is fed.		6.0 +0.1, -0.0
Run6	Better yield is pursued.		

Zr content variation $\leq \pm 1.0\%$.

Impurity (total of oxygen, carbon, nitrogen and silicon) $< 2000\text{ppm}$.

Density $15.8 +0.3, -0.5 \text{ g/cc}$.

Diameter variation $\leq \pm 0.05 \text{ mm}$ (average), $\leq \pm 0.1 \text{ mm}$ (local).

Effective slug length $> 400 \text{ mm}$.

Ratio of cast/loaded material $> 70\%$.

The qualified yield is more than 80% of the slug product, as is shown in Figure 8. Further improvement of the mold size precision, or the technique of the mold coating is needed to achieve higher yield.

Figure 8. Variation of the slug diameter

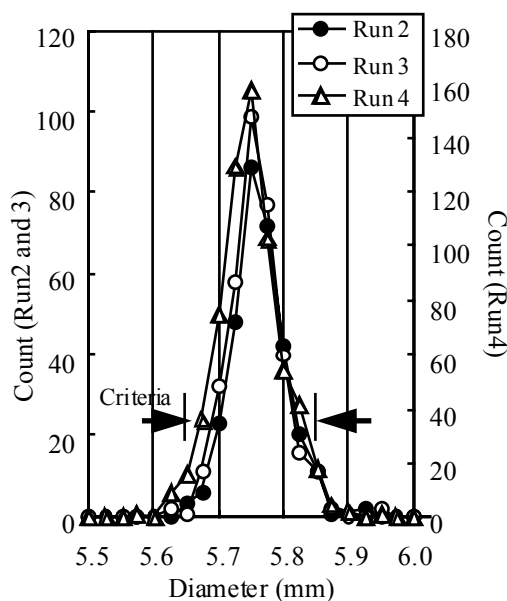

When retrieved, the heel is partly covered with oxide dross which is formed by the reaction between the alloy and coating material. But, as is shown in Figure 9, it is found that the dross can be peeled off the alloy relatively easily. The amount of the actinides included in the dross is calculated to be less than only 0.3% of the charged material. Another source of actinides oxide formation is the alloy adhesion on to the mold outer surface, which is shown in Figure 10. It is calculated about 0.6~0.8% of the charged actinides go here. These are not negligible values. To achieve a high actinides recovery ratio in terms of P&T goals, both process improvements to reduce the oxide formation and the treatment to recover the actinides from the oxide are needed.

Figure 9. Heel ingot from the injection casting and the peeled off dross



Figure 10. Fuel alloy adhesion at the bottom of the molds



Chlorination of actinides oxide

Background

As described above, considerable amount of actinide oxides can be formed in the actual pyro-process plant which may have various paths for the introduction of oxygen or moisture impurity. Those oxides should not go into the waste stream if a high actinides recovery ratio is pursued. Reduction by lithium or chlorination by Cl_2 gas are effective in recovering the actinides from the oxides, but, to treat either media, additional processes are required. In comparison, a chlorination method using ZrCl_4 appears promising, since it has a high reactivity with oxygen, and it can be compatible with the main process considering that zirconium is one of the major fuel components.

The Gibbs free energy changes (ΔG) in reactions expected for the ZrCl_4 chlorination process are calculated using the thermodynamic database. Table 3 shows ΔG obtained on condition that temperature is 500°C and oxide, chloride, oxychloride and metal are in their standard states. Uranium and plutonium in the trivalent state are stable in the LiCl-KCl eutectic system. Zirconium metal is needed to be used as a reductant when UO_2 and PuO_2 are to be chlorinated as in the reaction (a) and (d) of Table 3. If no reductant is added in the system, UO_2 may be converted into UCl_4 or UOCl_2 by ZrCl_4 . Rare-earth oxides and oxychlorides could be converted into trichlorides. It is suggested that uranium should be the most difficult element to chlorinate among the actinides and rare-earth fission products. In practice, the ZrCl_4 chlorination occurs in a molten LiCl-KCl eutectic bath, so the activity coefficients of the metal chlorides in the salt have to be taken into consideration.

Experimental

Uranium and plutonium oxides are reacted with ZrCl_4 in a molten LiCl-KCl eutectic bath at 500°C . All of the molten-salt experiments are conducted in a high-purity argon atmosphere glove box. The salt samples are dissolved in water and filtrated. Then, the concentrations of uranium, plutonium and zirconium in the solutions are determined by ICP-AES.

Table 3. ΔG in reactions expected for the $ZrCl_4$ chlorination process at 500°C

Reaction				ΔG (kcal/mol-O)
(a)	UO_2	+ 3/4 $ZrCl_4$	+ 1/4 $Zr \rightarrow$	$UCl_3 + ZrO_2$ -13.5
(b)	UO_2	+ $ZrCl_4$	\rightarrow	$UCl_4 + ZrO_2$ - 1.9
(c)	UO_2	+ 1/2 $ZrCl_4$	\rightarrow	$UOCl_2 + 1/2 ZrO_2$ - 2.9
(d)	PuO_2	+ 3/4 $ZrCl_4$	+ 1/4 $Zr \rightarrow$	$PuCl_3 + ZrO_2$ -29.4
(e)	$PuOCl_2$	+ 1/2 $ZrCl_4$	\rightarrow	$PuCl_3 + 1/2 ZrO_2$ -16.2
(f)	Y_2O_3	+ 3/2 $ZrCl_4$	\rightarrow	$2 YCl_3 + 3/2 ZrO_2$ -17.0
(g)	La_2O_3	+ 3/2 $ZrCl_4$	\rightarrow	$2 LaCl_3 + 3/2 ZrO_2$ -35.7
(h)	CeO_2	+ 3/4 $ZrCl_4$	+ 1/4 $Zr \rightarrow$	$CeCl_3 + ZrO_2$ -36.3
(i)	Nd_2O_3	+ 3/2 $ZrCl_4$	\rightarrow	$2 NdCl_3 + 3/2 ZrO_2$ -28.6
(j)	$NdOCl$	+ 1/2 $ZrCl_4$	\rightarrow	$NdCl_3 + 1/2 ZrO_2$ -17.8

To avoid vaporisation of $ZrCl_4$, which sublimes above 300°C, LiCl-KCl- $ZrCl_4$ mixtures are prepared by heating a sealed quartz tube containing LiCl-KCl eutectic (59:41mol%) and $ZrCl_4$ (purity 99.9%) up to 550°C. Once $ZrCl_4$ dissolves into a molten LiCl-KCl eutectic, little $ZrCl_4$ escapes from the salt as vapour.

Chlorination tests for UO_2 are carried out both in the presence and in the absence of zirconium metal reductant. In the first case, an alumina crucible containing LiCl-KCl eutectic (8.51g), LiCl-KCl-29wt% $ZrCl_4$ (0.150g) and UO_2 (0.099g) is heated up to 500°C. The molten-salt is stirred with a zirconium metal wire. The salt becomes dark wine red, which suggests trivalent uranium should exist. After a salt sample was taken, 1.00g of LiCl-KCl-29wt% $ZrCl_4$ is added into the salt. In the second case, LiCl-KCl eutectic (8.49g), LiCl-KCl-5.6wt% $ZrCl_4$ (2.82g) and UO_2 (0.190g) are loaded in a Pyrex test tube and melted at 500°C. The molten-salt is stirred with a quartz rod. The salt becomes yellow green, which suggests tetravalent uranium should exist. After 4 hours, a salt sample is taken out, when the precipitate of UO_2 remained.

In the chlorination of PuO_2 , an alumina crucible containing LiCl-KCl eutectic (22.966g), LiCl-KCl-6.2wt% $ZrCl_4$ (1.895g) and PuO_2 (0.101g) is heated up to 500°C. The molten-salt is stirred with a zirconium metal wire. The salt becomes blue, which suggests trivalent plutonium should exist.

Results and discussions

The results of the UO_2 test conducted in the presence of zirconium metal are shown in Figure 11. The metal contents of the salt phase are plotted against the amount of $ZrCl_4$ added into the salt. The mass balance calculation suggests that the following reactions should progress.

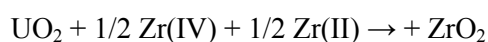
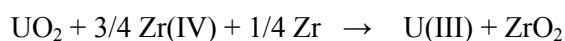

It is obvious that UO_2 is completely chlorinated by adding an excess of $ZrCl_4$. Time dependence of the uranium concentration in the salt phase is investigated after the second $ZrCl_4$ addition. Within 3 hours, the reaction seems to be finished. In the UO_2 test conducted in the absence of zirconium metal, no more than 37% of UO_2 is chlorinated and dissolves into the salt phase with 79% of $ZrCl_4$ solute remaining after 4 hours have passed. As $UOCl_2$ is insoluble in molten chlorides, UCl_4 could be yielded in the test.

The results of the PuO₂ test are shown in Figure 12. In this case, excessive is added and PuO₂ is fully chlorinated after 3 hours. The mass balance calculation suggests that the following reactions should progress.

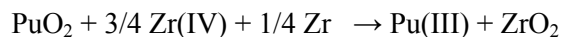

Figure 11. Amount of U and Zr in the salt phase as a function of the amount of ZrCl₄ added

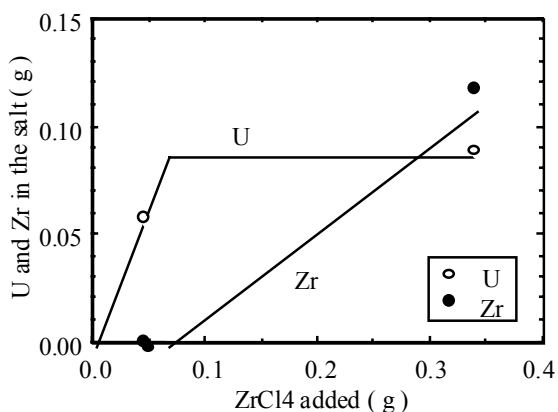
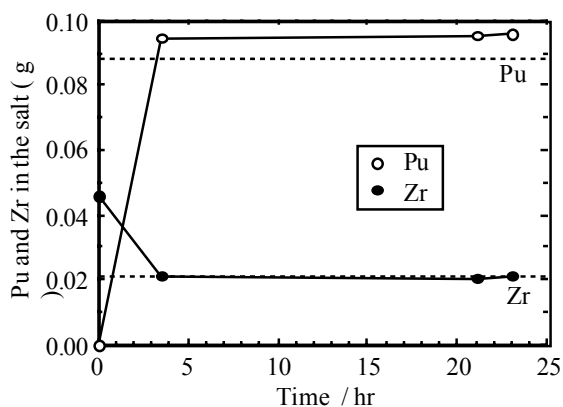

Figure 12. Change in the amount of Pu and Zr dissolved in the salt after the salt melted at 500 uA



Conclusions

Recent results of CRIEPI's pyro-process fuel cycle technology developments in pursuit of higher actinides recovery are reported.

On the actinides deposition into liquid cadmium cathode, a series of experiments are conducted using a small scale electro-refiner, in an effort to investigate the suitable condition for co-deposition of U and TRUs at a better current density. Pu/U ratio in the salt is varied from ∞ to 1.7 and it is shown that U can be collected together with Pu and Am. More than 10 weight per cent of actinides are successfully deposited in the cathode forming compounds with Cd, which indicates that the liquid cadmium cathode can be reasonably compact. When the U content is relatively high (Pu/U < 2.0), U is preferably collected after the cathode Cd is saturated. This result suggests that the balance between the deposition rate and the mixing of the cathode content should be carefully taken into account in the liquid cadmium cathode design.

The design considerations to realise better yields in injection casting are clarified by conducting 20 kg/batch scale tests using U-Zr. It is shown that most of the specifications such as the uniformity of slug diameter and density can be satisfied. Some studies on the oxide dross formation due to the reaction between the molten fuel and crucible coating or casting mold are also conducted and it is suggested that more than negligible amount of oxide may be formed.

It is shown that uranium and plutonium oxides are completely chlorinated with ZrCl₄ in a LiCl-KCl eutectic bath at 500°C. These results suggest that the chlorination using ZrCl₄ is promising as the method for the recovery of the actinides from oxides formed in various points of the pyro-process, for the purpose of achieving a very high recovery ratio.

REFERENCES

- [1] T. Inoue *et al.* (1991), *Nucl. Technol.*, 93, 206.
- [2] R.W. Benedict, H.F. McFarlane and K.M. Goff (2001), *Electrometallurgical Treatment of Sodium-bonded Spent Nuclear Fuel*, Proc. of GLOBAL.
- [3] L.C. Walters, B.R. Seidel and J.H. Kittel (1984), *Nucl. Technol.*, 65, 179.
- [4] T. Ogata *et al.* (2002), Fall Meeting of the AESJ, E-17.
- [5] Y. Sakamura, T. Inoue and H. Moriyama (2001), *Chlorination of Uranium and Rare-earth Oxides by Use of $ZrCl_4$ in Molten LiCl-KCl*, Proc. of 6th International Symposium on Molten-salt Chemistry and Technology, p.292, Oct. 2001 Shanghai.