

Experimental Neutron Cross Section Measurements in the Fast Range

Donald L. Smith

Argonne National Laboratory (retired)

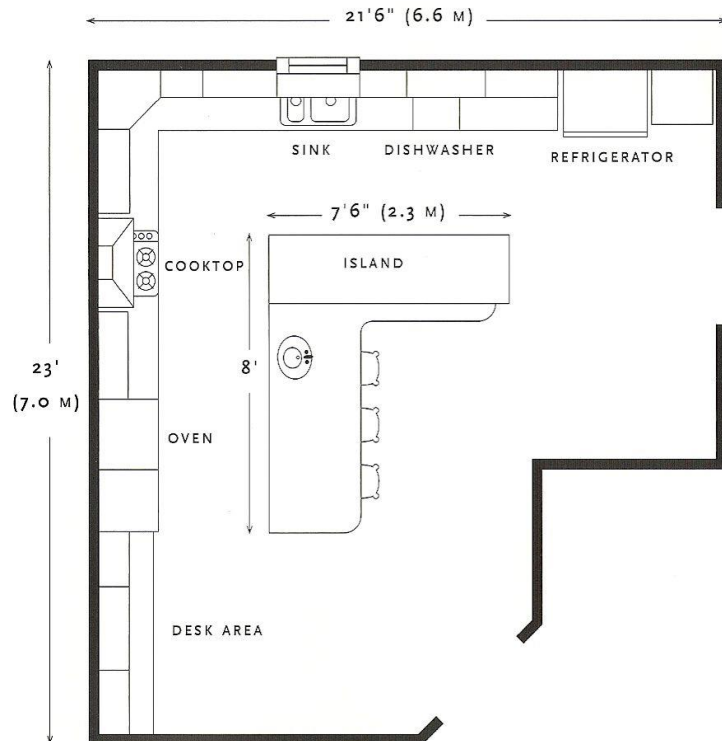

Data User View of an
"Experiment Setup"
(A simplistic diagram)



Data Compiler / Evaluator View of an
"Experiment Setup"
(Detailed rendition but very tidy)



Experimenter View of an
"Experiment Setup"
(Cluttered and disorganized)



*“ ... Every **experiment** is like landing a jet fighter plane on an aircraft carrier ... essentially it’s a **controlled crash**. You feel lucky each time it’s accomplished without a serious mishap ...”*

--- Alan B. Smith

Experiments can be **messy** and **difficult** so the overall **quality** of archived cross-section data tends to **reflect** this **reality** ...

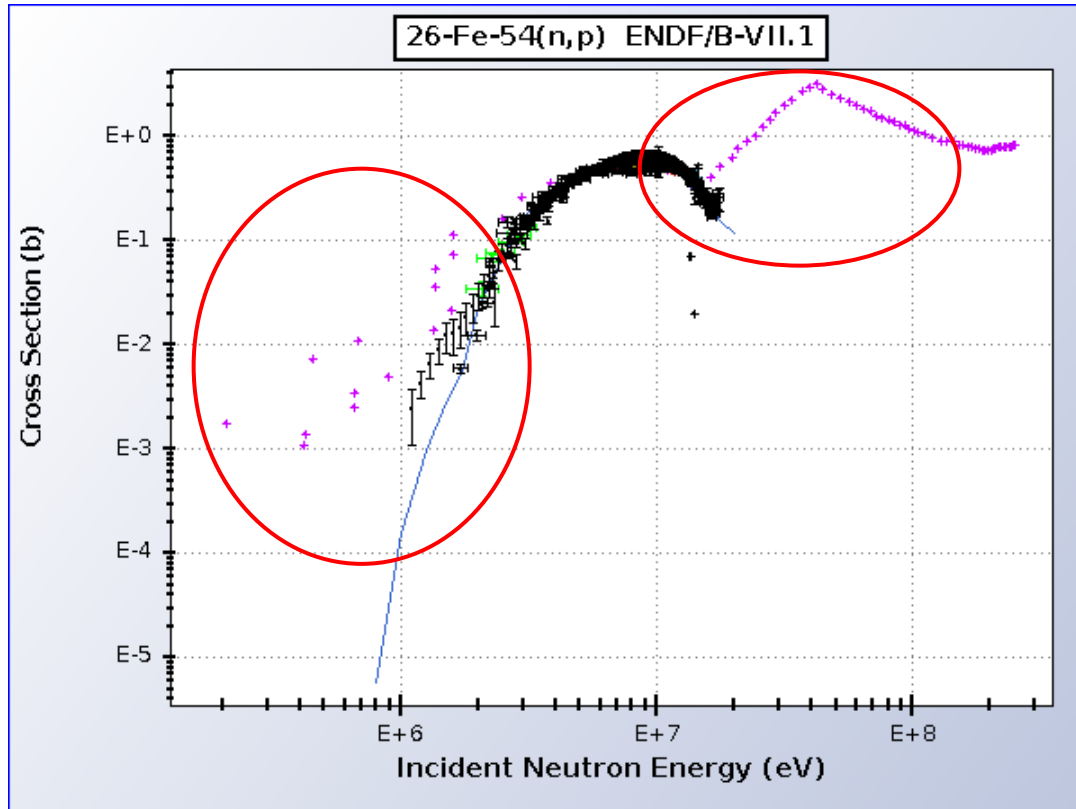

- Obvious energy-scale issues
- Physically unrealistic shapes

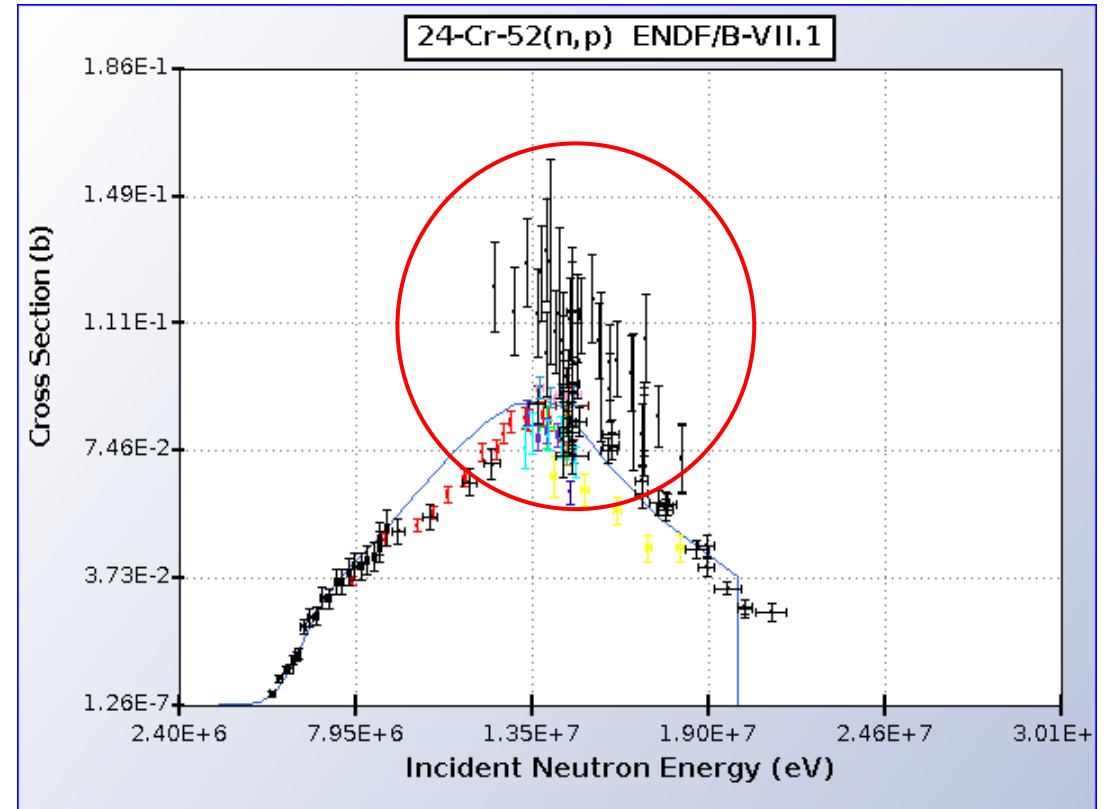

- Obviously discrepant data
- Over- or under-estimated errors

The **goals** of WPEC Subgroup 50 are **ambitious** ...

*“... This subgroup aims to **develop** an automatically and unambiguously readable differential experimental data format and **generate** from accordingly updated EXFOR files a more comprehensive and curated experimental reaction database. ...”*

--- WPEC sub-group proposal (14 April 2020)

Considering the **difficulty** of producing **trustworthy** experimental **data**, how can this **reality** be **reconciled** with the **SG50 goal** of **automating** with **confidence** the processes of **retrieving data** and **employing** these values **directly** for applications with little or no human intervention? This a **fundamental question** that SG50 needs to address.

In my opinion, **investigation** of **automated** data **retrieval** procedures is a **worthy endeavor** to be pursued, but **without sacrificing** ongoing efforts to **improve** the overall **quality** of the **nuclear database** that is employed for application purposes.

We need to acknowledge an **inconvenient truth** ...

Experimenters **rarely** can **measure directly** those particular physical parameters that **they** actually **desire** to determine. Therefore, these quantities must be **derived** from the measured results using data-analysis **models** of the **experiments** that can be rather **simplistic**. This is an issue especially when interpreting data from **older experiments**.

It would be nice if all experiments were this “perfect” ...

Thin Spherical
Sample Shell

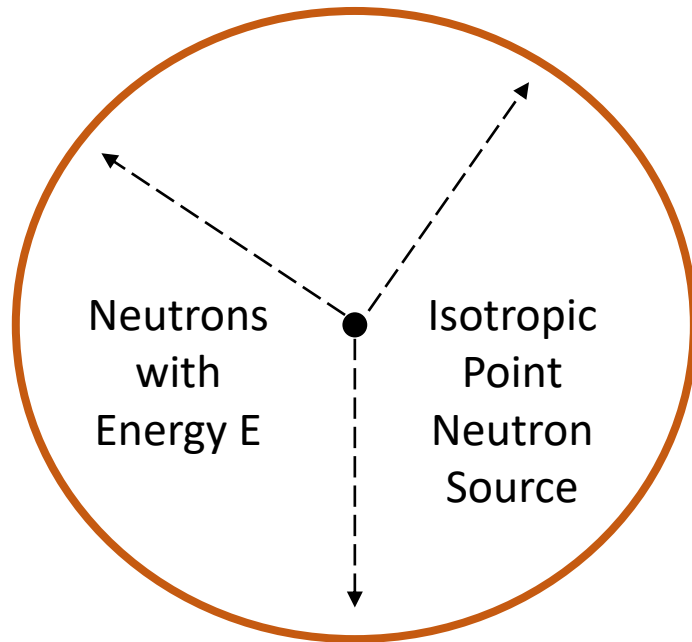

$$Y = N \Phi(E) \sigma(E)$$

Y = Total reaction yield in the sample

N = Number of applicable sample atoms

$\Phi(E)$ = Monoenergetic total neutron fluence

$\sigma(E)$ = Monoenergetic reaction cross section

... This **ideal situation** is **not achievable** in practice for many reasons. Some of these are mentioned in this presentation.

A **more realistic** but still idealized experimental configuration to consider for discussion purposes ...

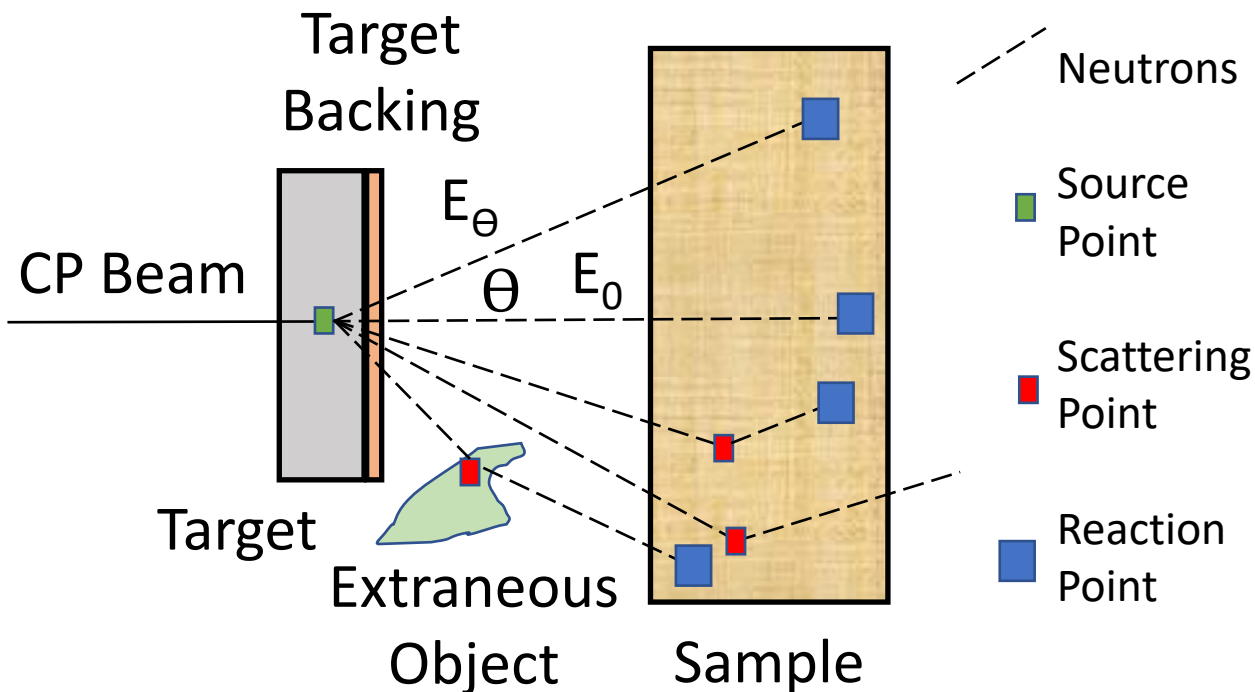

NOTE: Neutron activation cross-section measurements are used to illustrate the points mentioned in this presentation.

Some Complications to Consider

- CP energy loss in the target
- Neutrons are NOT monoenergetic
- Neutrons produced in the backing
- Neutron scattering in the sample, target, extraneous objects, etc.
- Kinematics ($E_0 > E_\theta$)
- Neutron source production and scattering are rarely isotropic
- Energy-resolution effects
- Energy-scale determination issues

➔ A number of **corrections** to raw data are inevitably needed in order to derive **desired results**.

Two widely-used CP-induced neutron source reactions ...

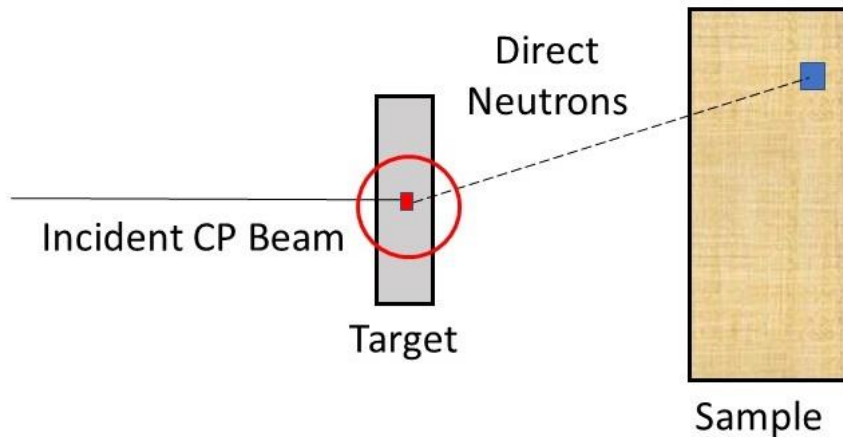

Lithium Source (${}^7\text{Li} + \text{p} \rightarrow \text{n}$)

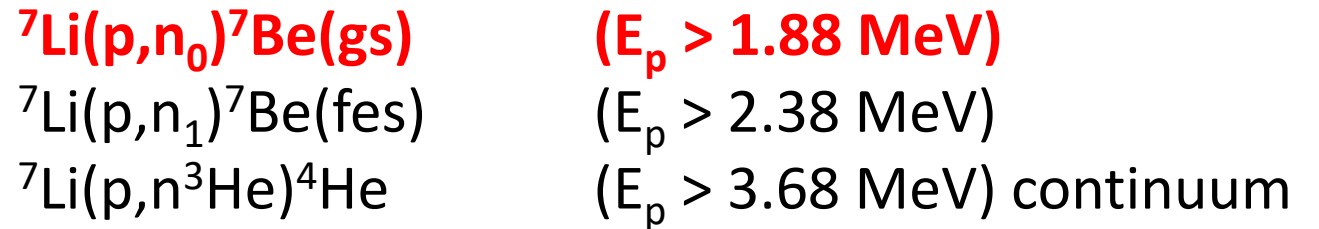

Report ANL/NDM-53 (1980)

Deuterium Source (${}^2\text{H} + \text{d} \rightarrow \text{n}$)

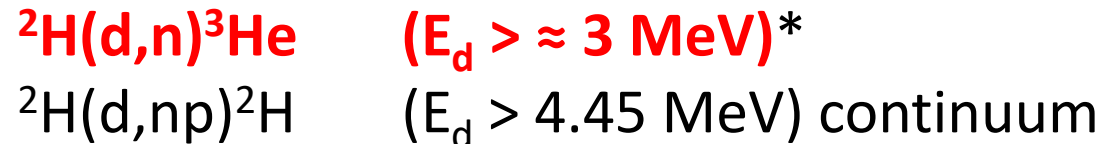

*Although this reaction has a positive Q-value, the neutron yield from this source is effectively negligible below 3 MeV.

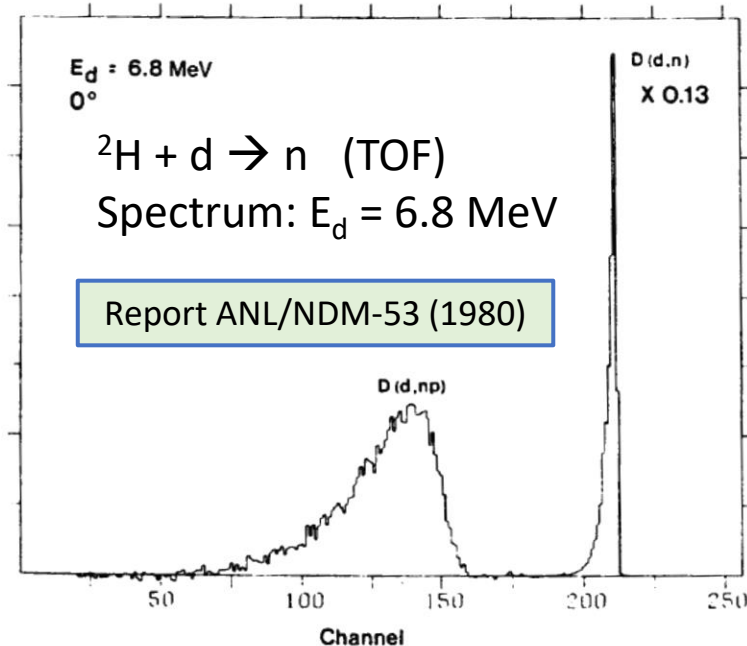

Usable **ranges** for common CP-induced so-called “**monoenergetic**” neutron source reactions ...

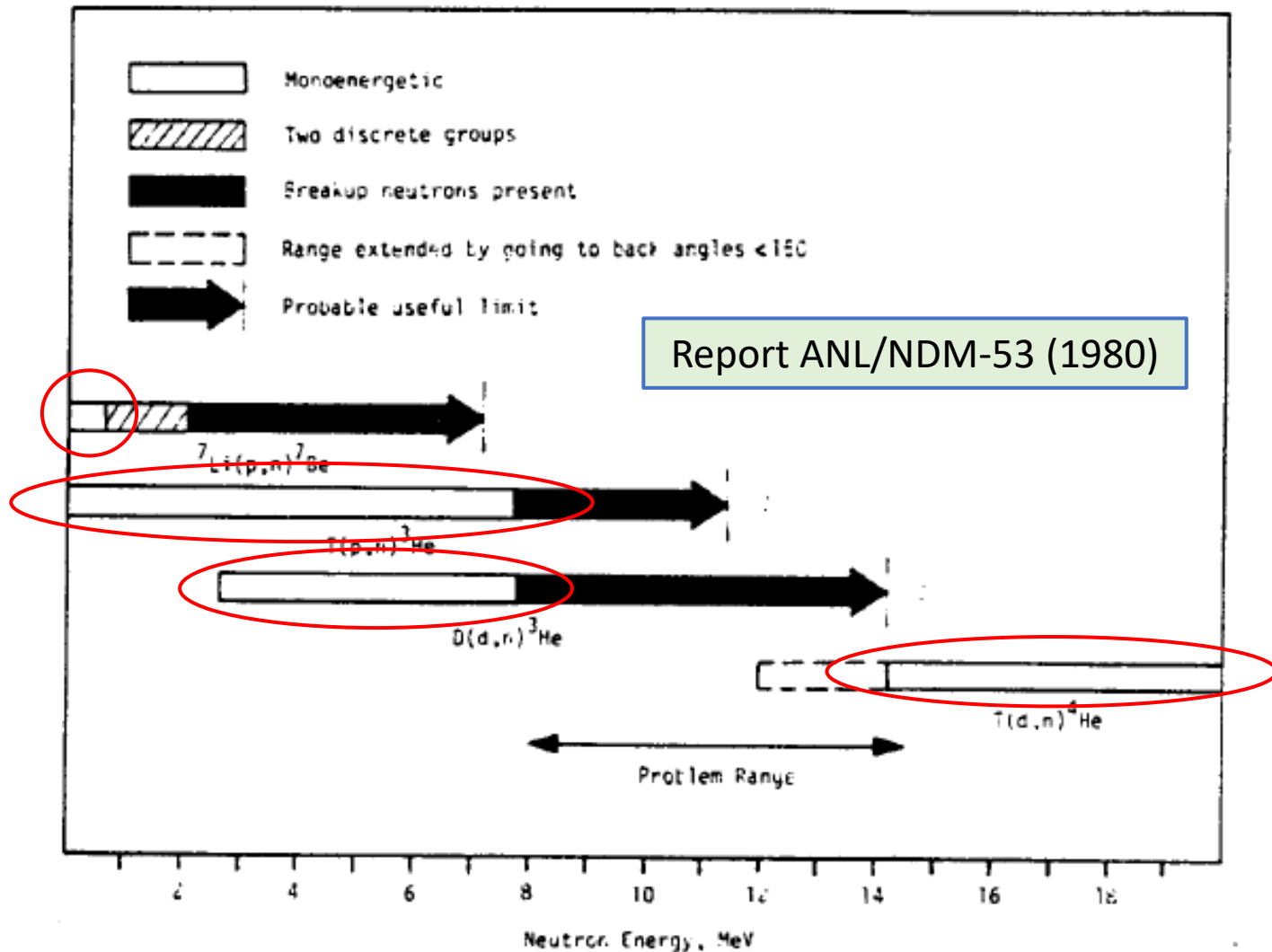

- The **energy ranges** where neutrons are inherently **monoenergetic** are **limited**.
- But, useful energy ranges can be **extended** if experimental **techniques** are employed and appropriate **corrections** are applied to the data.

Correcting measured reaction yields for secondary neutrons ...

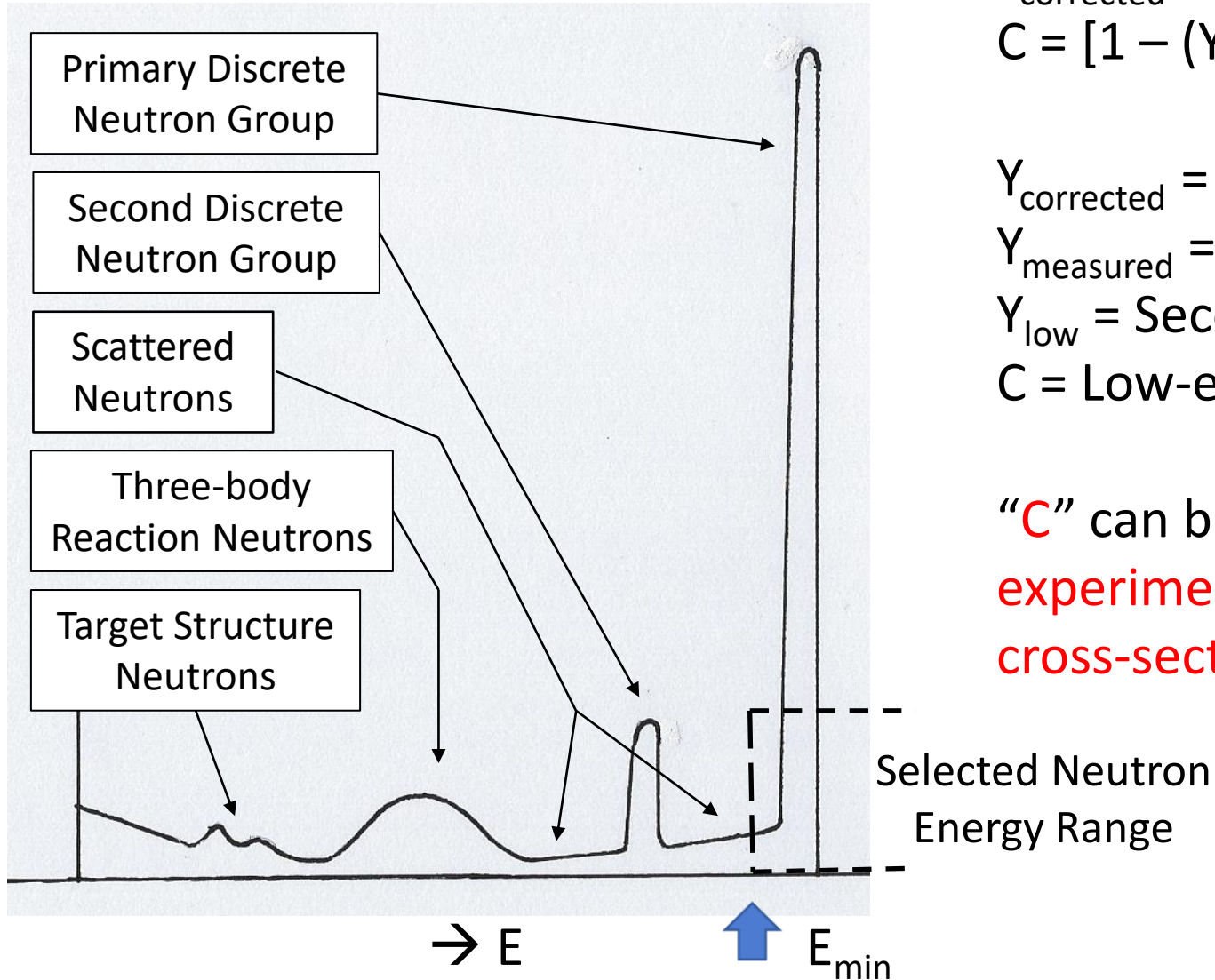

$$Y_{\text{corrected}} = Y_{\text{measured}} - Y_{\text{low}} = C Y_{\text{measured}}$$
$$C = [1 - (Y_{\text{low}} / Y_{\text{measured}})] < 1 \quad (\text{always})$$

$Y_{\text{corrected}}$ = Primary-group reaction yield

Y_{measured} = Total measured reaction yield

Y_{low} = Secondary-neutron reaction yield ($E < E_{\min}$)

C = Low-energy neutron correction factor

“ C ” can be calculated by **Monte-Carlo** using **experiment models** in combination with **estimated cross-sections** and neutron **spectrum shapes**.

If “ C ” is significantly < 1 , **uncertainties** in this correction factor can be **large**.

Sample **activity** measurements also require **corrections** ...

Report ANL/NDM-14 (1975)

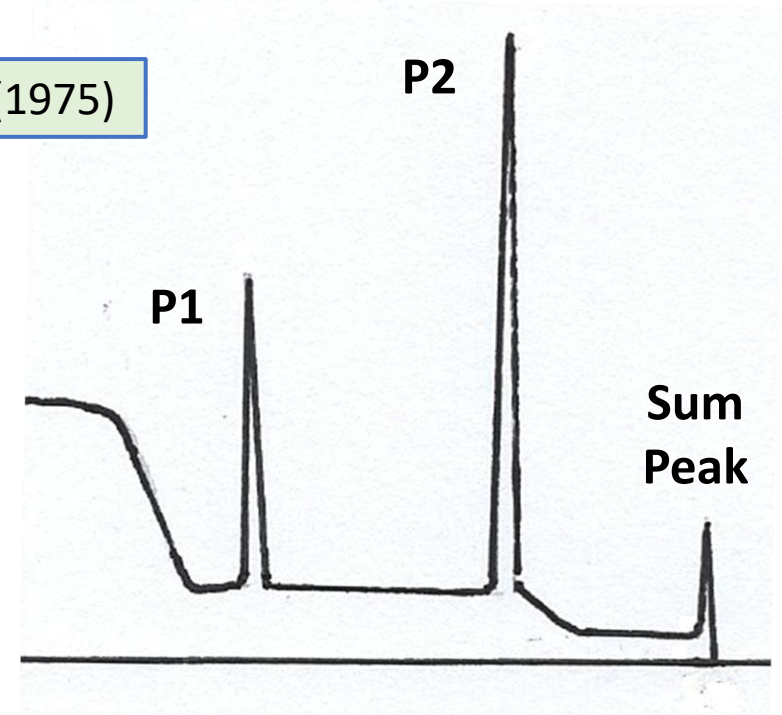
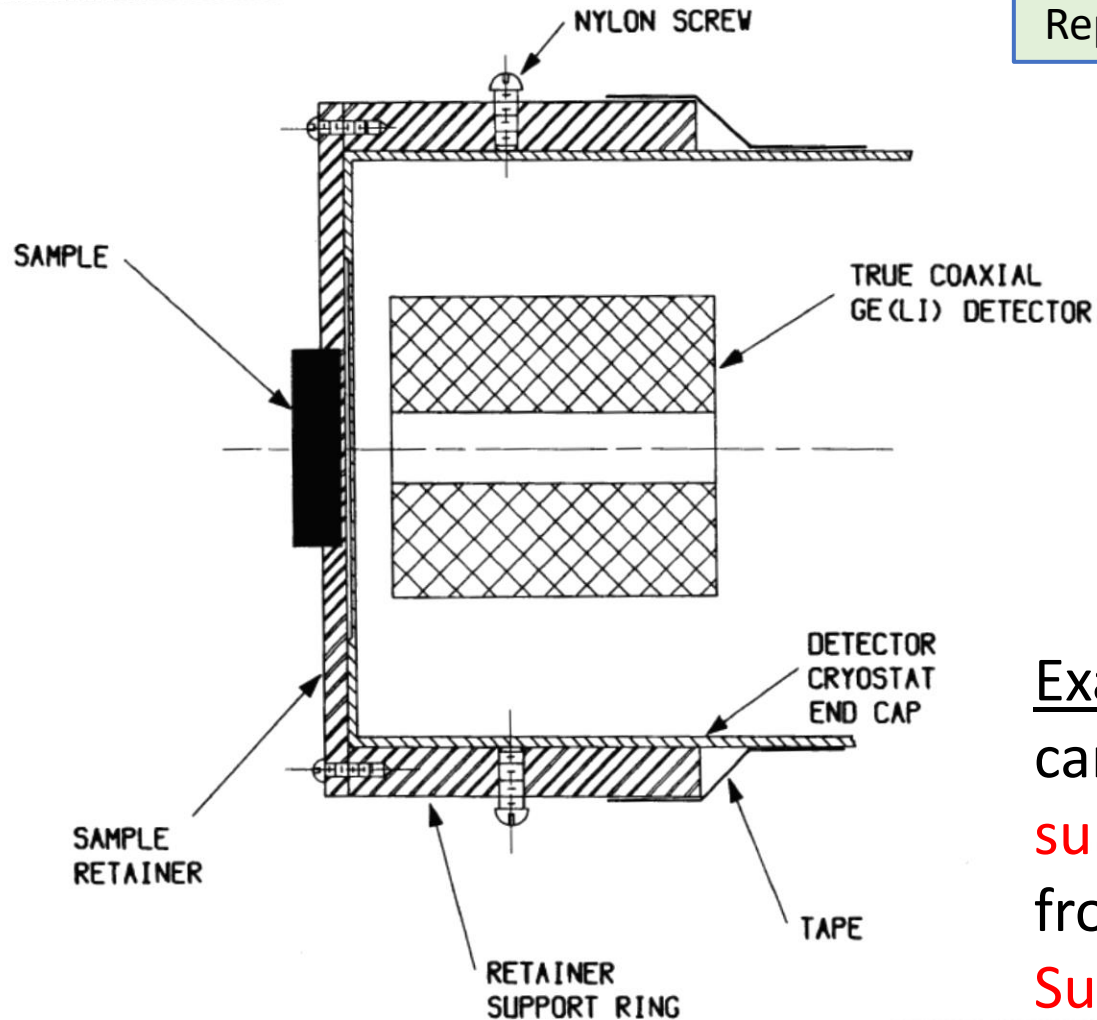

Example: **Gamma-ray** counting in **close geometries** can alter the effective detector **calibration** due to **sum-coincidence** effects that “subtract” counts from FE peaks P1 and P2 and “deposit” them in a **Sum Peak** and the **Continuum** part of the spectrum.

Data **analysis** involves **estimating** and **applying** many such **corrections** to measured values in order to derive **quantitative results** that approach as closely as possible the **true values** of those **physical quantities** needed for applications ...

- It's **impossible** to achieve this **ideal** situation **entirely**, but with careful attention to experimental details it should be possible to approach **close enough** in most instances.
- The **archived data** for applications should reflect the **best** achievable **quality standards**. **Otherwise**, their **automatic retrieval** and **direct use** in applications may be **risky**.

Question: How can it be **established** whether **particular** sets of archived **data** are sufficiently **trustworthy** to be **retrieved automatically** and used in **applications**?

Even with **attention** to the **details** and **corrections** mentioned here, it **cannot be guaranteed** that archived **experimental data** will necessarily be sufficiently **reliable**. **Unrecognized disruptions** can **affect** experimental **outcomes** ...

- Oversights
- Carelessness
- Blunders

So, **automated** nuclear **data retrieval** should incorporate **algorithms** that can **screen** for the presence of seriously **flawed data** ... This should benefit from using Artificial Intelligence (**AI**) and Machine Learning (**ML**) procedures.

Oversights

Report ANL/NDM-12 (1975)

SHADOW
BAR

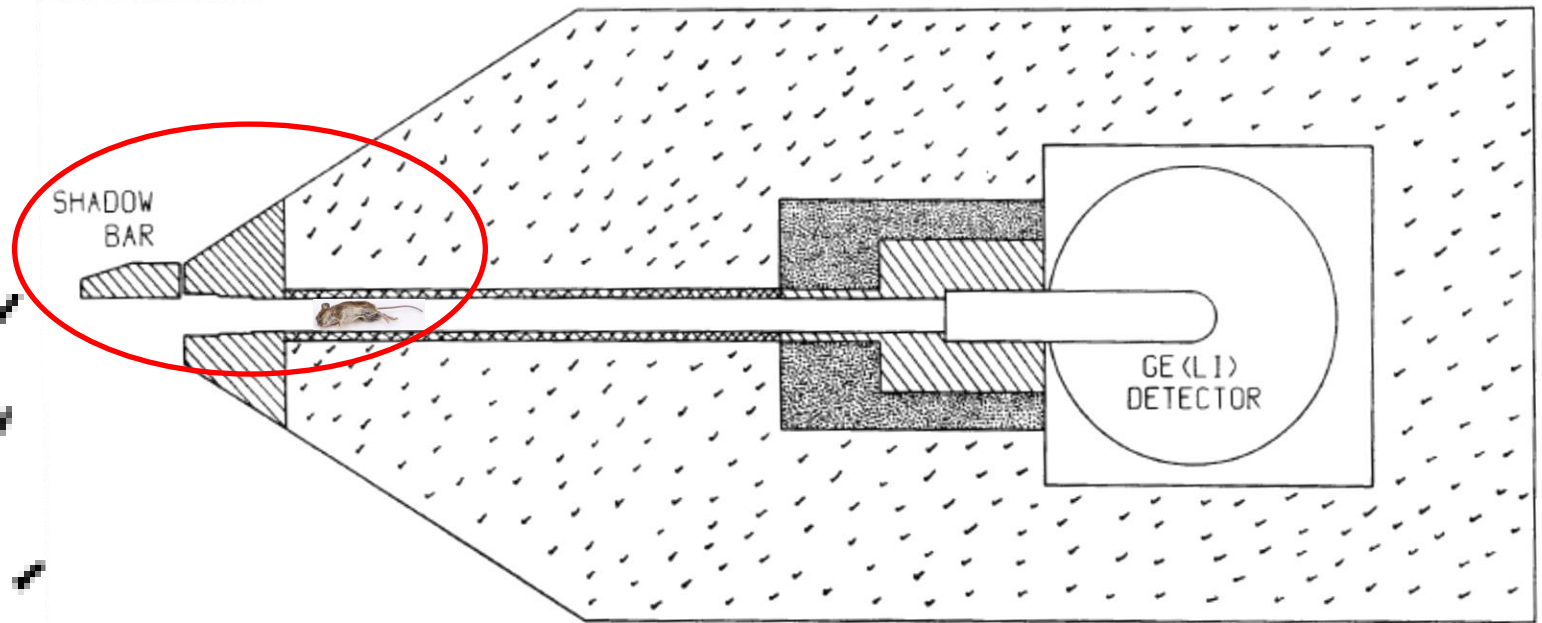
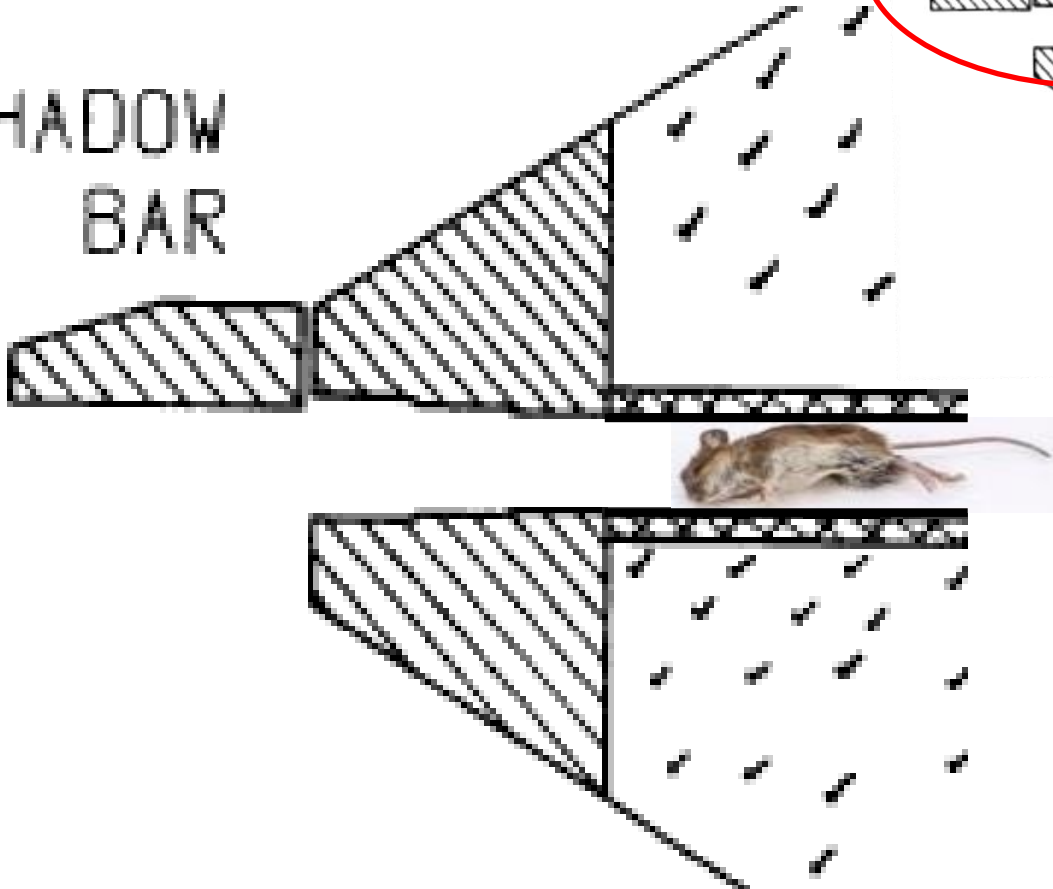

Obstructions in collimator systems (e.g., the **dead mouse**) can lead to **systematic biases** in the recorded **data** that may not be apparent. Such data usually are very **difficult** to **correct**.

Carelessness

Data Set *	Date	Sample	Start Irradiation	Stop Irradiation	Start Count	Stop Count
A-01	03/15/77	Ti-06	09:12	10:15	10:32	10:53
A-02	03/15/77	?	11:08	12:16	13:04	13:22
A-03	03/15/77	Ti-17	14:02	15:25	15:30	15:44
A-04	03/15/77	Ti-18	16:20	?	17:40	17:59
A-05	03/15/77	Ti-03	18:13	19:37	?	21:07

* Hypothetical data

Only **two** out of **five** data sets are **usable** because of **failures** to **record** information in the **logbook**. This can happen during marathon late-night measurement sessions when **scientists** and their support **staff** are **tired**.

Blunders

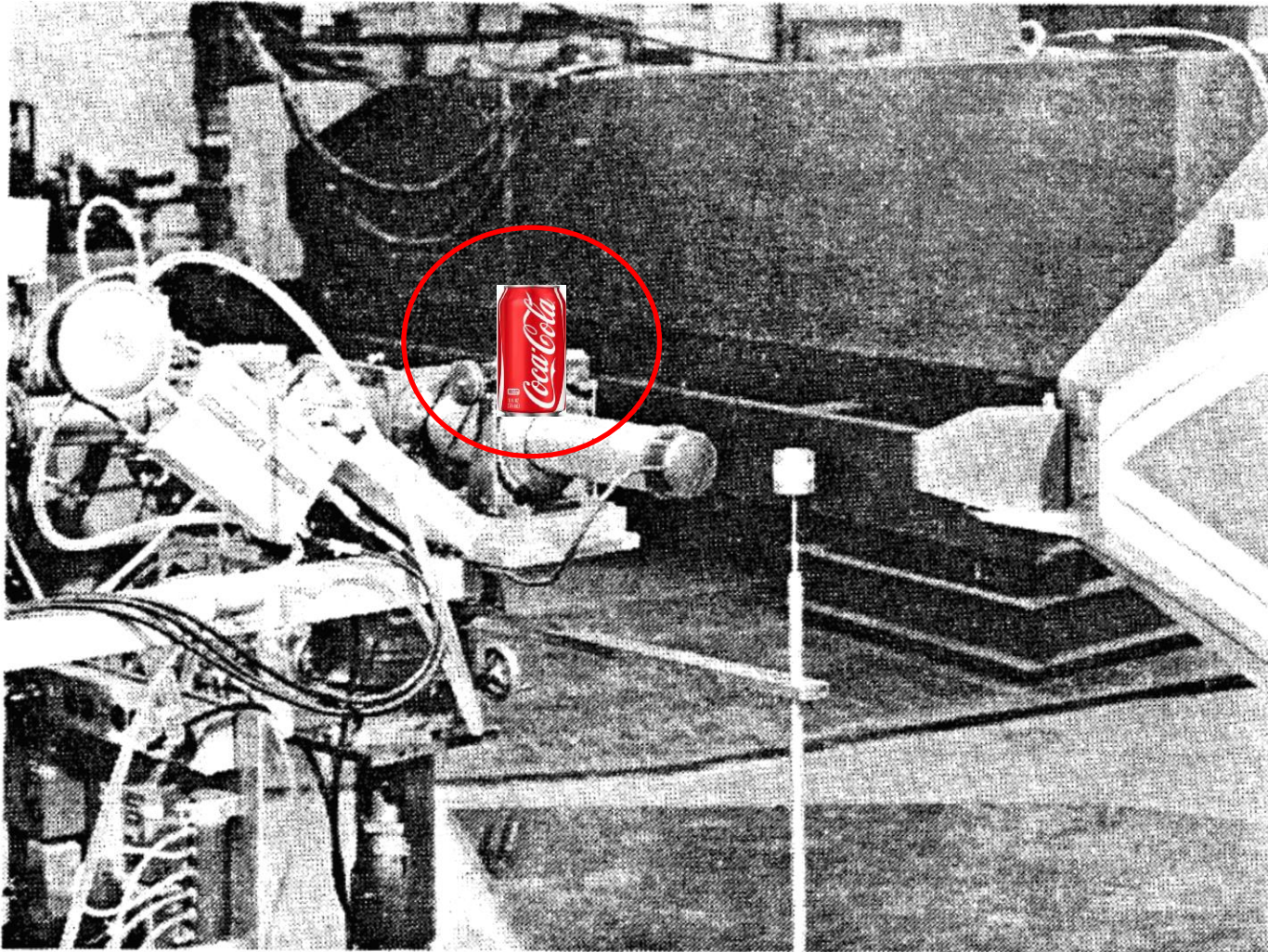

Report ANL/NDM-53 (1980)

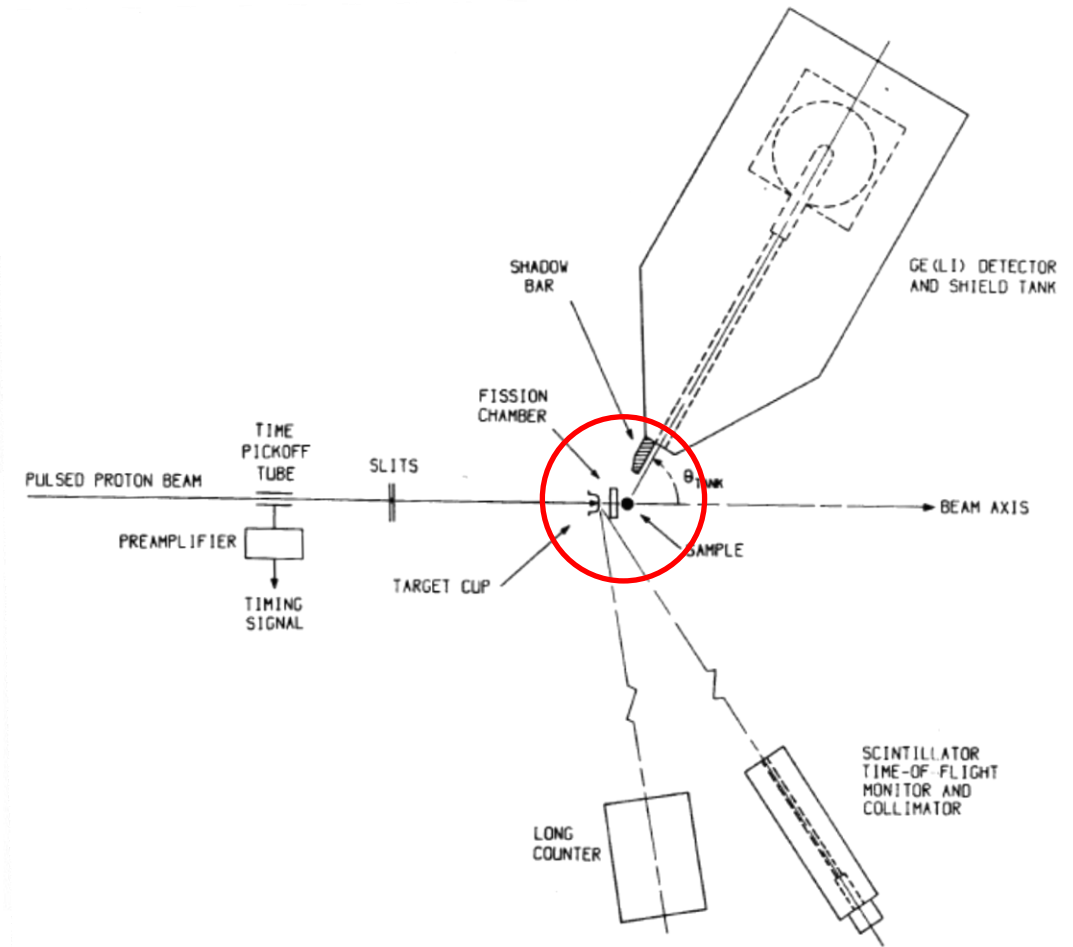

Extraneous objects left amid the apparatus can alter neutron spectra in hard-to-detect ways.

Measurements



+



Analyses → Archived Data

Quality governs performance ...



Archived
Nuclear Data
Retrieval



G I G O

Application
Performance

?



?



Summary

- Full **confidence** in the use of **automated** data **retrieval** procedures will depend strongly on possessing a nuclear database of **good quality** and **consistency** within the uncertainties.
- Continued **expenditure** of **human labor** will be needed to **improve** the **reliability** of available **nuclear data** ... combined with investigation of procedures to **automatically retrieve** these data efficiently for use in **nuclear applications**.
- Artificial Intelligence (**AI**) and Machine Learning (**ML**) tools can be used to **identify** **bad experimental data** that result from **flaws** in the **measurements** (oversights, carelessness, and blunders) and/or ensuing **data analyses**.

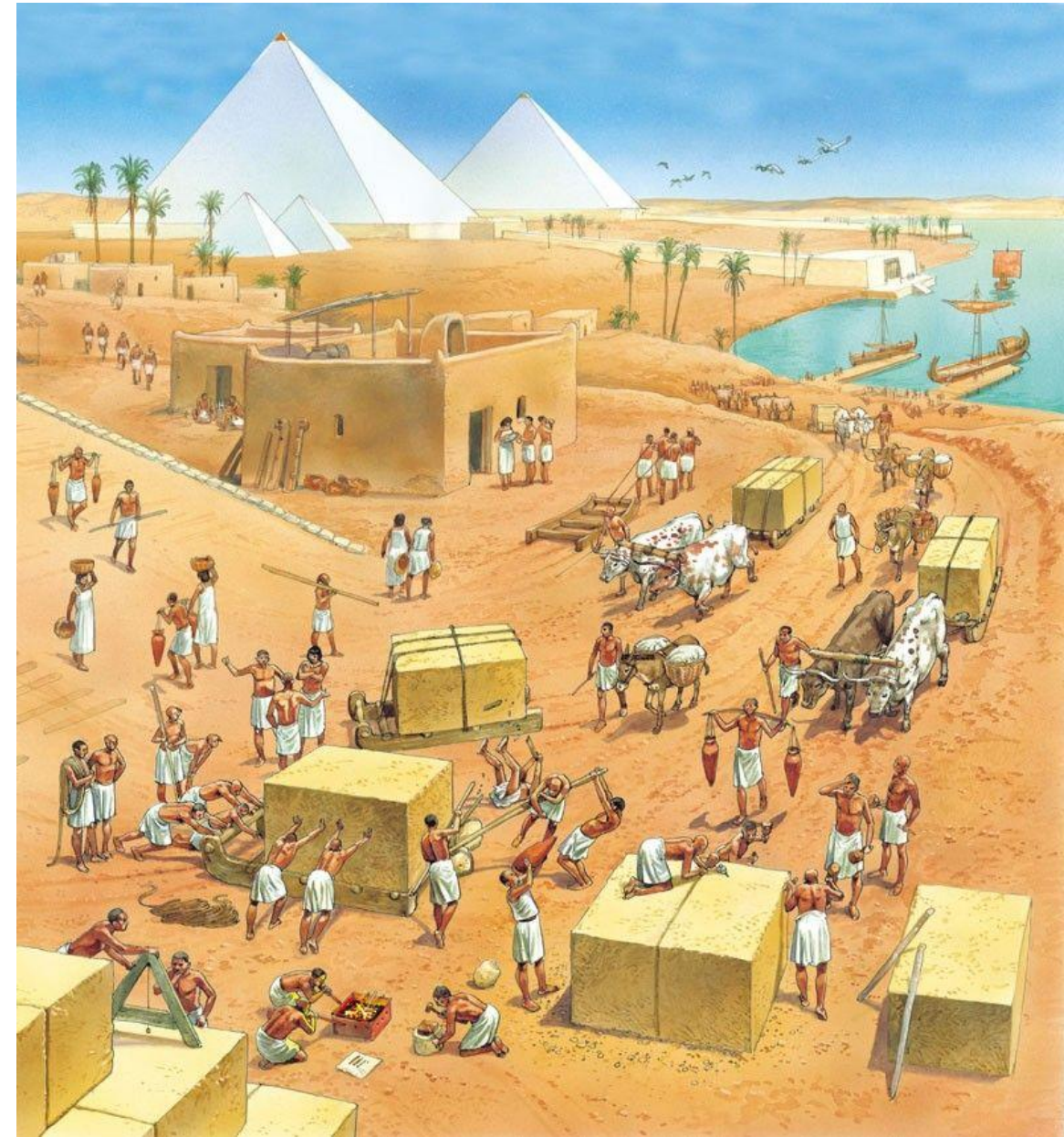

A final thought ...

- A directory of cross-section data in **EXFOR format** found at the NNDC website includes **Internet links** to **references** (where available). However, some of these might **not be** easily **accessible** or provide **useful** added **information** for evaluation and application purposes.

```
Quantity: [CS] Cross section 1 +iX4X4+X4± T4Cov 1987 S.M.Qaim+ 1.00e7 1.05e7 2 + J,NSE,96,52,1987 22049004 1987QA01
2) (26-FE-54 (N,A) 24-CR-51, , SIG) / (26-FE-56 (N,P) 25-MN-56, , SIG) C4: MF= MT=
Quantity: [CS] Cross section 2 +iX4X4+X4± T4Cov 1979 A.Paulsen+ 6.41e6 1.40e7 9 + J,NSE,72,(1),113,7910 21309004 #2:1979pazn
3) (26-FE-54 (N,P) 25-MN-54, , SIG) / (26-FE-56 (N,P) 25-MN-56, , SIG) C4: MF= MT=
Quantity: [CS] Cross section 3E+iX4X4+X4± T4Cov 1979 A.Paulsen+ 6.41e6 1.40e7 9 + J,NSE,72,(1),113,7910 21309003 #2:1979pazn
```

- It also would be valuable if a **capability** could be **introduced** to specify **links** to archived **photos**, **audio clips**, or **video clips** for the **individual experiments**. This would provide extra **qualitative information** that might **benefit** data **evaluators** and data **users**.

- The **technologies** and **storage capabilities** to handle such added information do **exist** ... For example, video platforms like **YouTube** might be employed. A **challenge** would be to get the **original researchers** to **generate** these **extra materials** and then agree to **disseminate** them. **Propriety** rights would need to be **protected**.



The End