



Validation of nuclear data against accelerator experiments in SINBAD

Yurdunaz Çelik
Alexey Stankovskiy
Gert Van den Eynde

ycelik@sckcen.be
SCK•CEN, Mol, Belgium

MYRRHA-project: an Accelerator Driven System

- MYRRHA – An Accelerator Driven System
 - Demonstrate the ADS concept at pre-industrial scale
 - Can operate in critical and sub-critical modes
 - Demonstrate transmutation
 - Fast neutron source → multipurpose and flexible irradiation facility

Target	
<i>main reaction</i>	spallation
<i>output</i>	$2 \cdot 10^{17}$ n/s
<i>material</i>	LBE (coolant)

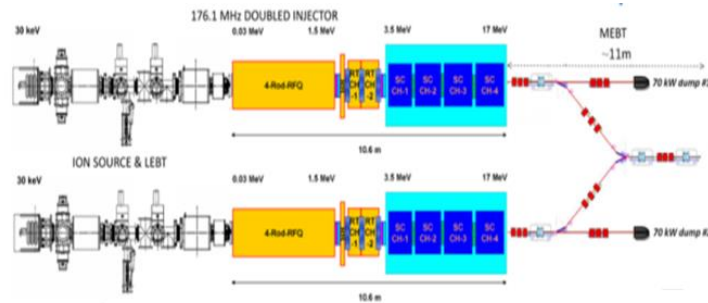

Accelerator	
<i>particles</i>	protons
<i>beam energy</i>	600 MeV
<i>beam current</i>	2 - 4 mA

Reactor	
<i>power</i>	60 to 70 MW _{th}
<i>k_{eff}</i>	0.95
<i>spectrum</i>	fast
<i>coolant</i>	LBE

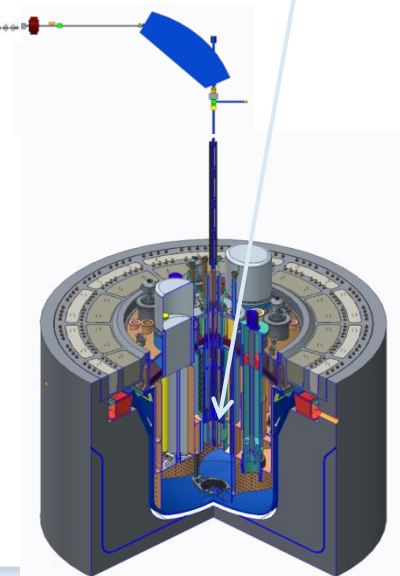

Experimental benchmarks in SINBAD

3 experiments are relevant to benchmark our codes for shielding calculations of 100 MeV accelerator and target stations:

- SINBAD-52P (NEA-1552/34)
- SINBAD-75P (NEA-1552/31)
- SINBAD-65P (NEA-1552/08)

Experimental benchmarks in SINBAD

SCK & JAEA collaboration to validate Mcnp6.2, Phits codes, and nuclear data using SINBAD experiments

SINBAD abstract No.	Facility	Source	Shielding materials	outputs
NEA-1552/34	Cyclotron of the Institute of Nuclear Study at the University of Tokyo	Neutrons and photons at 0 degree produced by 52-MeV proton on a thick graphite	graphite, water, concrete, iron	neutron and photon energy spectra behind shieldings
NEA-1552/03	AVF cyclotron of the TIARA facility in JAERI	Neutrons at 0 degree produced by 43- and 68- MeV proton on a lithium	concrete, iron	neutron energy spectra behind shieldings
NEA-1552/23	KEK Spallation Neutron Source Facility (KENS)	Neutrons at 0 degree produced by 500- MeV proton on a thick tungsten	concrete	reaction rate at each depth in concrete
NEA-1552/15	Cyclotron in the Swiss Institute for Nuclear Research (SIN)	590-MeV proton	lead	neutron energy spectrum
NEA-1552/38	Intense spallation neutron source facility, ISIS, of the Rutherford Appleton Laboratory (RAL)	Neutrons at 90 degrees produced by 800- MeV proton on a thick tantal	iron+concrete	reaction rate at each depth in iron+concrete

Sinbad-experiment: 52 MeV p + C

Transmitted neutron spectra measurement

Impact of proton induced libraries

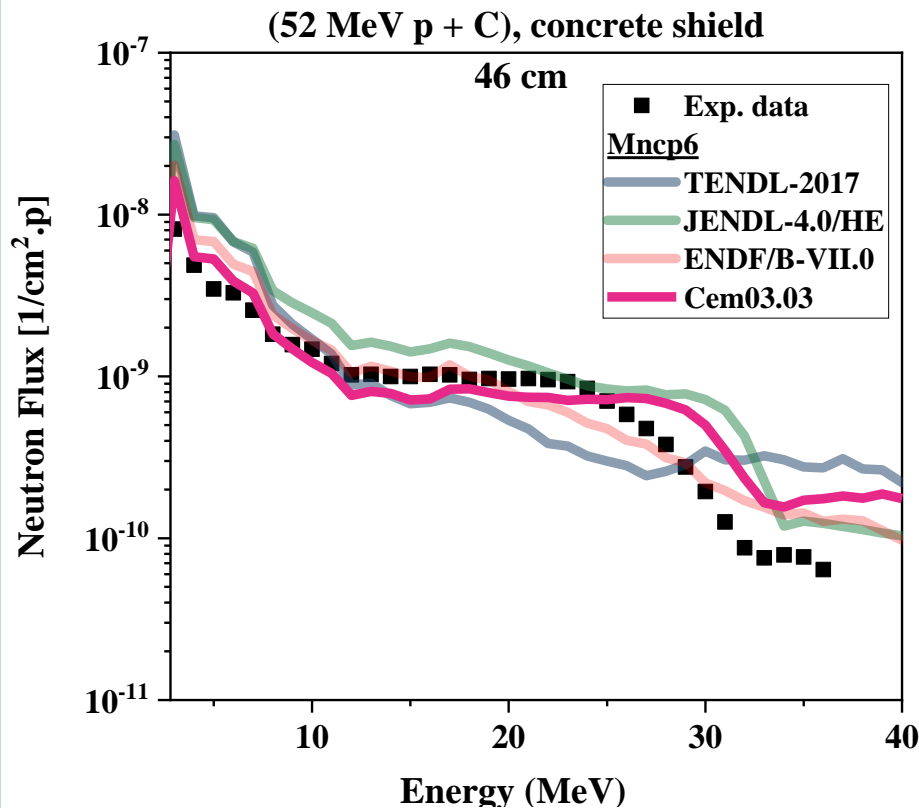

neutron: Jeff-3.3

Impact of neutron induced libraries

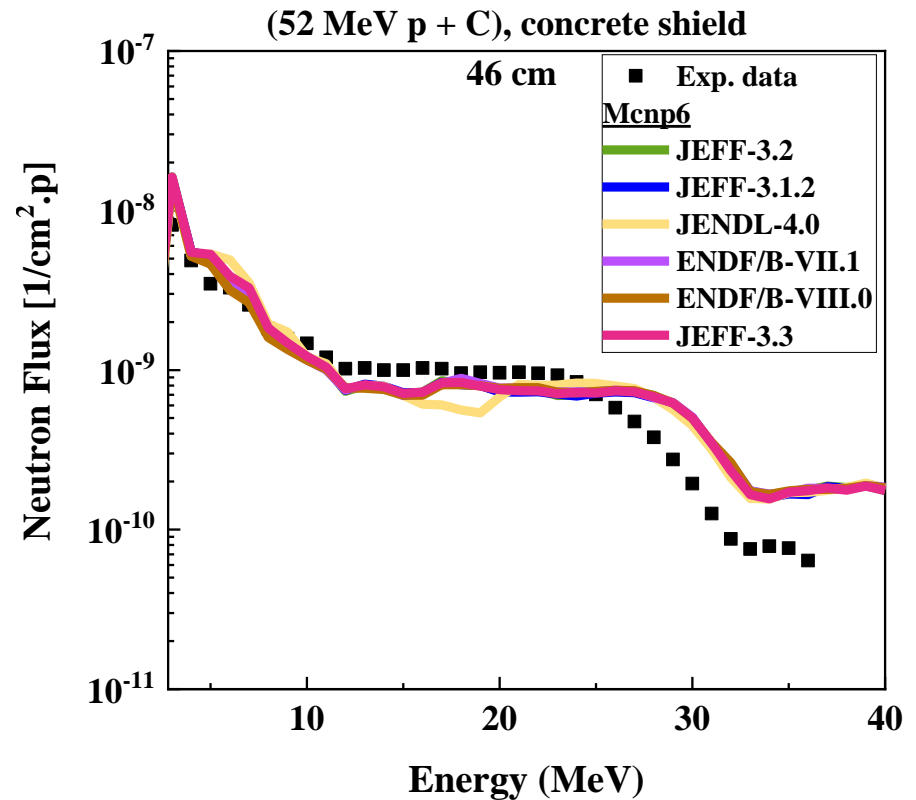

proton: Cem03.03

Sensitivity to neutron library is low

Sinbad-experiment: $Tiara=48\text{ MeV p} + 7\text{Li}$ Transmitted neutron spectra measurement

Impact of proton induced libraries

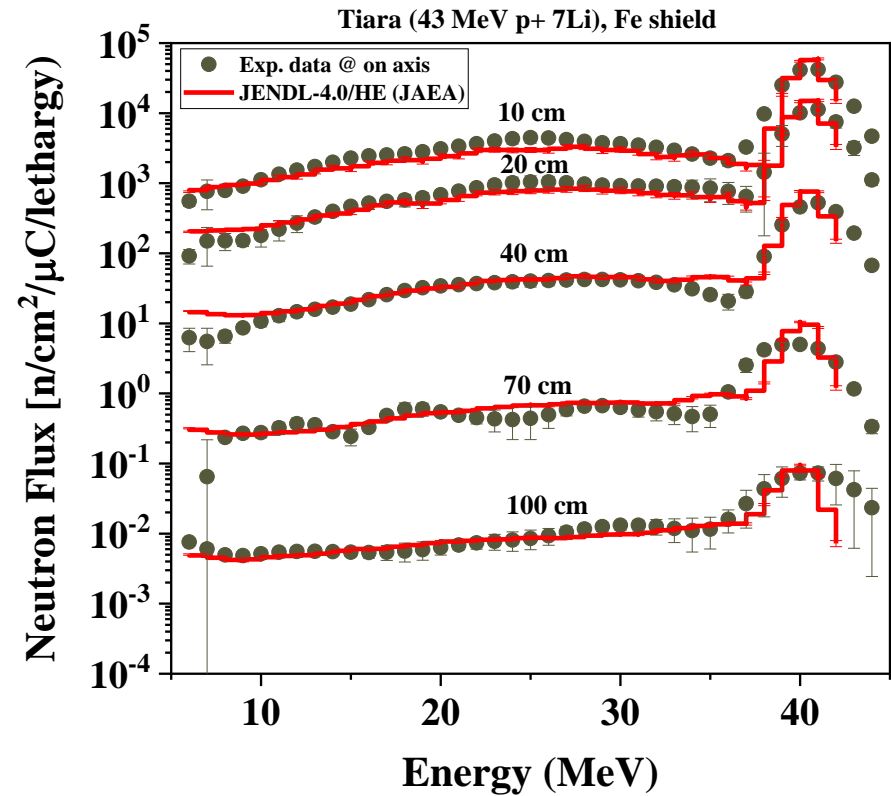
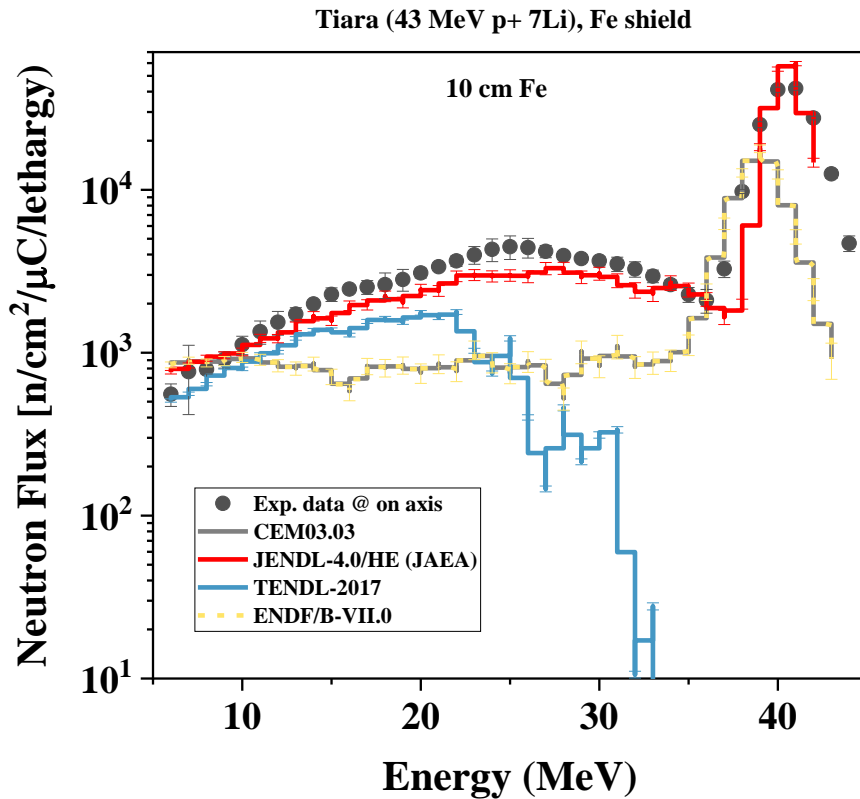

neutron:Jendl-4.0/HE

Proton data determines the shape of transmitted neutron spectra

Sinbad-experiment: $A_{vf}=75$ MeV p + Cu

Neutron yield measurement

Impact of proton induced libraries

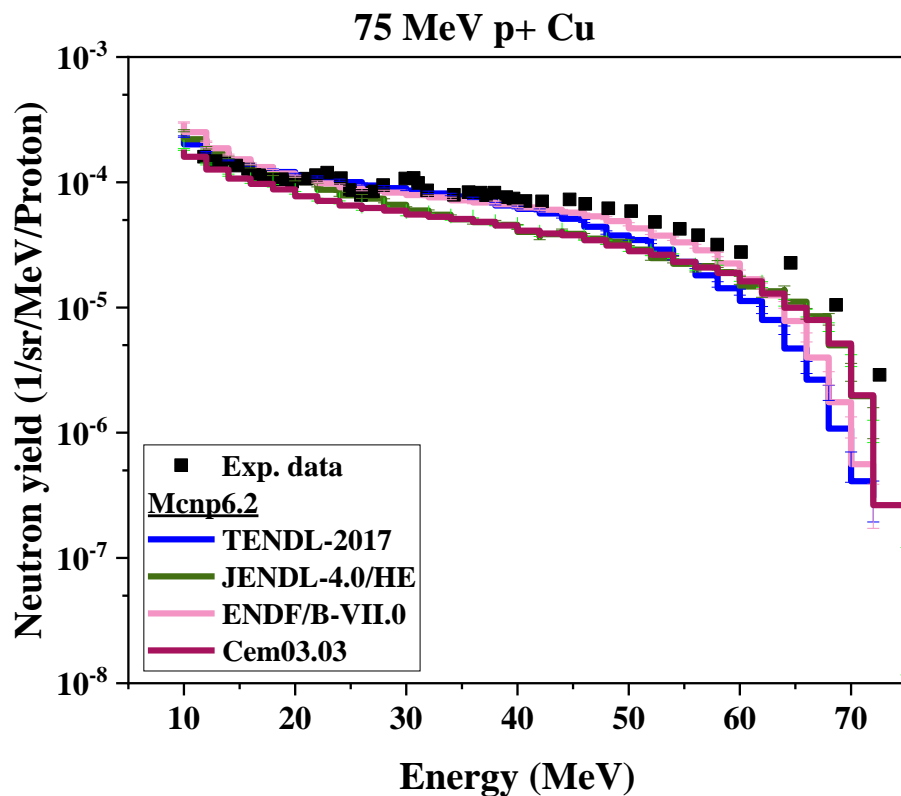

neutron: Jeff-3.3

Impact of neutron induced libraries

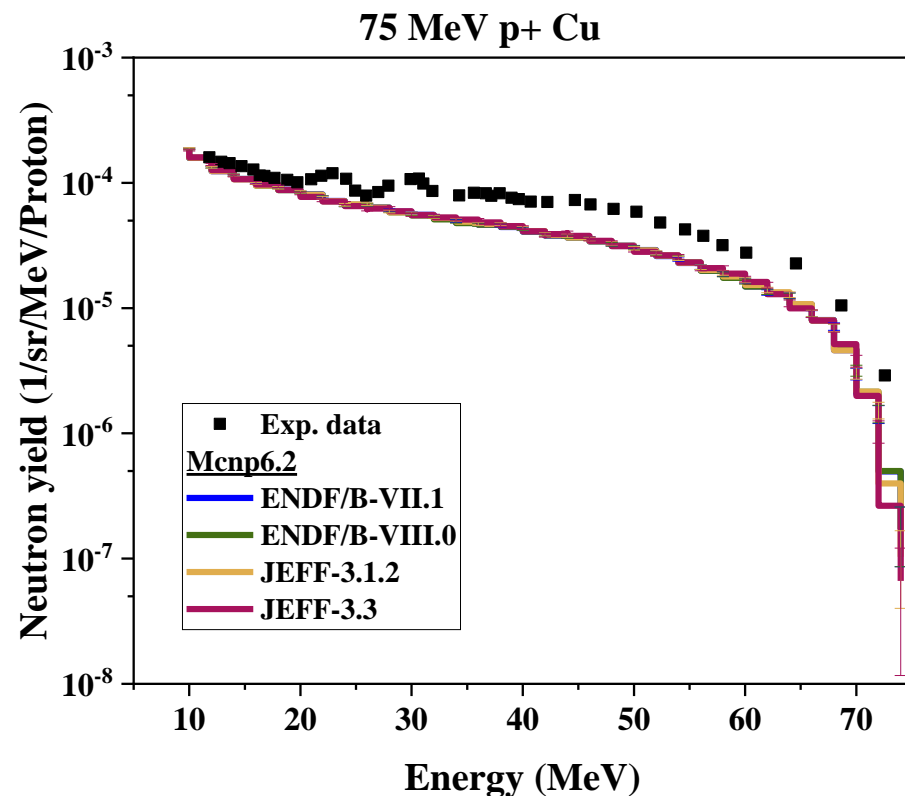

proton: Cem03.03

Conclusions

- The quality of experimental data is questionable. Uncertainties for the experiments should be provided in the SINBAD database. The quality of documentation of the experiments should be increased.
- There is no nuclear data or physics model accurately represent the experimental data of all considered experiments.
- Proton induced libraries are responsible for the production and spectra of the neutrons emitted from target materials.
- Neutron libraries reflect the flux profile determined by proton data/physics models.
- High quality proton induced library is required. Light-Z targets (Li, C) are more difficult to deal with and deserve special attention.
- More experiments at different energies and different target materials are necessary.



Copyright © 2018 - SCK•CEN

PLEASE NOTE!

This presentation contains data, information and formats for dedicated use ONLY and may not be copied, distributed or cited without the explicit permission of the SCK•CEN. If this has been obtained, please reference it as a “personal communication. By courtesy of SCK•CEN”.

SCK•CEN

Studiecentrum voor Kernenergie
Centre d'Etude de l'Energie Nucléaire
Belgian Nuclear Research Centre

Stichting van Openbaar Nut
Fondation d'Utilité Publique
Foundation of Public Utility

Registered Office: Avenue Herrmann-Debrouxlaan 40 – BE-1160 BRUSSELS
Operational Office: Boeretang 200 – BE-2400 MOL