



GOBIERNO  
DE ESPAÑA

MINISTERIO  
DE CIENCIA, INNOVACIÓN  
Y UNIVERSIDADES

**Ciemat**

Centro de Investigaciones  
Energéticas, Medioambientales  
y Tecnológicas



POLITÉCNICA

UNIVERSIDAD  
POLITÉCNICA  
DE MADRID

# Status on MYRRHA, ESFR, ASTRID and ALFRED

P. Romojaró<sup>1</sup>, N. García-Herranz<sup>2</sup>, A. Martínez<sup>2</sup>, A. Jiménez-Carrascosa<sup>2</sup>,  
F. Álvarez-Velarde<sup>1</sup> and O. Cabellos<sup>2</sup>

[pablo.romojaró@ciemat.es](mailto:pablo.romojaró@ciemat.es)

(1) Centro de Investigaciones Energéticas, Medioambientales y Tecnológicas (CIEMAT)

(2) Universidad Politécnica de Madrid (UPM)



- Provide R-Z models by next meeting:
  - MYRRHA
  - ESFR
  - ASTRID
  - ALFRED
- List of recommended integral parameters, associated sensitivities and uncertainty analyses
- Verify interest of adding the low Na void ASTRID-like systems provided by F. Gabrielli
- Look at the SFR-UAM benchmarks to determine if they should be included in the TAR exercise



- Provide R-Z models by next meeting:
  - **MYRRHA** (sent to M. Fleming)
  - **ESFR** (pending)
  - **ASTRID** (sent to M. Fleming)
  - **ALFRED** (developed by ENEA – see G. Grasso's presentation)
- **List of recommended integral parameters, associated sensitivities and uncertainty analyses**
- **Verify interest of adding the low Na void ASTRID-like systems provided by F. Gabrielli**
- **Look at the SFR-UAM benchmarks to determine if they should be included in the TAR exercise**



- R-Z model developed
- **Based on MYRRHA v1.6 (2014) Critical core only**  
at BOL
- Dimensions and materials provided in an Excel spreadsheet
- **Sent to M. Fleming (8/11/2019)**

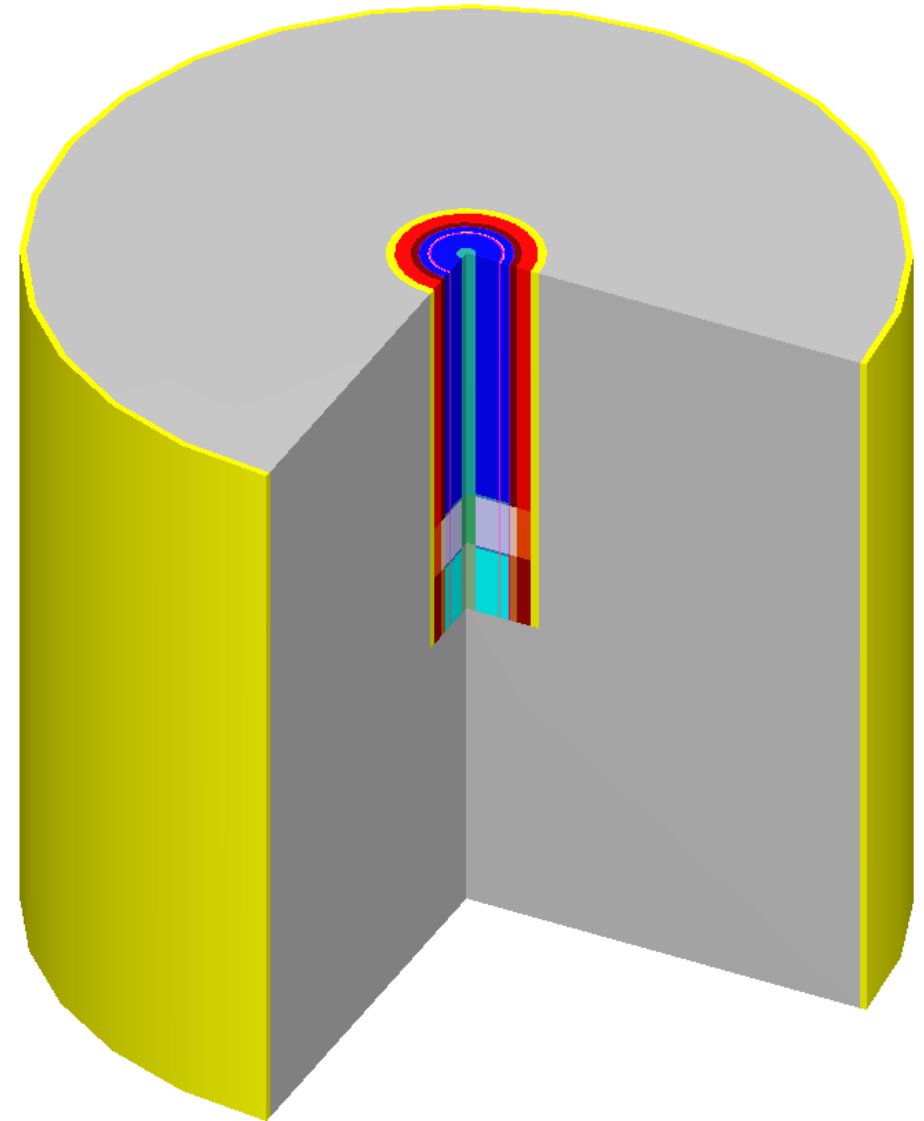



- **S/U analyses performed** with **SUMMON** and **JEFF-3.3** for  $k_{eff}$ ,  $\beta_{eff}$ ,  $\Lambda_{eff}$ , Doppler, voiding and CR worth
  - Homogenised on FA level model used

MYRRHA – $k_{eff}$ ISC (%/%)		
Quantity		JEFF-3.3
$^{239}\text{Pu}$	$\nu$	$0.696 \pm 2.9 \cdot 10^{-6}$
$^{239}\text{Pu}$	(n,f)	$0.482 \pm 2.9 \cdot 10^{-6}$
$^{238}\text{U}$	(n, $\gamma$ )	$-0.112 \pm 3.7 \cdot 10^{-7}$
$^{241}\text{Pu}$	$\nu$	$0.091 \pm 4.5 \cdot 10^{-7}$
$^{240}\text{Pu}$	$\nu$	$0.081 \pm 4.5 \cdot 10^{-7}$
$^{238}\text{U}$	$\nu$	$0.070 \pm 6.1 \cdot 10^{-7}$
$^{241}\text{Pu}$	(n,f)	$0.064 \pm 4.6 \cdot 10^{-7}$
$^{240}\text{Pu}$	(n,f)	$0.055 \pm 4.6 \cdot 10^{-7}$
$^{239}\text{Pu}$	(n, $\gamma$ )	$-0.053 \pm 3.1 \cdot 10^{-7}$
$^{209}\text{Bi}$	(n,n)	$0.052 \pm 1.1 \cdot 10^{-5}$

MYRRHA - JEFF-3.3			
Quantity		$\Delta k_{eff}/k_{eff}$ (%)	
$^{240}\text{Pu}$	(n,f)	$^{240}\text{Pu}$	(n,f) $0.543 \pm 7.3 \cdot 10^{-7}$
$^{240}\text{Pu}$	(n,f)	$^{240}\text{Pu}$	(n, $\gamma$ ) $-0.420 \pm 1.4 \cdot 10^{-7}$
$^{239}\text{Pu}$	$\nu_p$	$^{239}\text{Pu}$	$\nu_p$ $0.321 \pm 1.1 \cdot 10^{-7}$
$^{239}\text{Pu}$	(n,f)	$^{239}\text{Pu}$	(n,f) $0.295 \pm 2.6 \cdot 10^{-7}$
$^{239}\text{Pu}$	$\chi$	$^{239}\text{Pu}$	$\chi$ $0.261 \pm 2.0 \cdot 10^{-6}$
$^{240}\text{Pu}$	(n, $\gamma$ )	$^{240}\text{Pu}$	(n, $\gamma$ ) $0.197 \pm 2.3 \cdot 10^{-8}$
$^{239}\text{Pu}$	(n,f)	$^{239}\text{Pu}$	(n, $\gamma$ ) $0.174 \pm 4.3 \cdot 10^{-8}$
$^{238}\text{U}$	(n, $\gamma$ )	$^{238}\text{U}$	(n, $\gamma$ ) $0.167 \pm 3.6 \cdot 10^{-8}$
$^{239}\text{Pu}$	(n, $\gamma$ )	$^{239}\text{Pu}$	(n, $\gamma$ ) $0.151 \pm 6.7 \cdot 10^{-8}$
$^{238}\text{U}$	(n,n')	$^{238}\text{U}$	(n,f) $-0.138 \pm 5.6 \cdot 10^{-7}$
<b>Total uncertainty in <math>k_{eff}</math></b>		<b><math>0.772 \pm 3.7 \cdot 10^{-6}</math></b>	



- **S/U analyses performed** with **SUMMON** and **JEFF-3.3** for  $k_{eff}$ ,  $\beta_{eff}$ ,  $\Lambda_{eff}$ , Doppler, voiding and CR worth
  - Homogenised on FA level model used

MYRRHA – $k_{eff}$ ISC (%/%)		
Quantity		JEFF-3.3
$^{239}\text{Pu}$	$\nu$	$0.696 \pm 2.9 \cdot 10^{-6}$
$^{239}\text{Pu}$	(n,f)	$0.482 \pm 2.9 \cdot 10^{-6}$
$^{238}\text{U}$	(n, $\gamma$ )	$-0.112 \pm 3.7 \cdot 10^{-7}$
$^{241}\text{Pu}$	$\nu$	$0.091 \pm 4.5 \cdot 10^{-7}$
$^{240}\text{Pu}$	$\nu$	$0.081 \pm 4.5 \cdot 10^{-7}$
$^{238}\text{U}$	$\nu$	$0.070 \pm 6.1 \cdot 10^{-7}$
$^{241}\text{Pu}$	(n,f)	$0.064 \pm 4.6 \cdot 10^{-7}$
$^{240}\text{Pu}$	(n,f)	$0.055 \pm 4.6 \cdot 10^{-7}$
$^{239}\text{Pu}$	(n, $\gamma$ )	$-0.053 \pm 3.1 \cdot 10^{-7}$
$^{209}\text{Bi}$	(n,n)	$0.052 \pm 1.1 \cdot 10^{-5}$

MYRRHA - JEFF-3.3			
Quantity		$\Delta k_{eff}/k_{eff}$ (%)	
$^{240}\text{Pu}$	(n,f)	$^{240}\text{Pu}$	(n,f) $0.543 \pm 7.5 \cdot 10^{-7}$
$^{240}\text{Pu}$	(n,f)	$^{240}\text{Pu}$	(n, $\gamma$ ) $-0.420 \pm 1.4 \cdot 10^{-7}$
$^{239}\text{Pu}$	$\nu_p$	$^{239}\text{Pu}$	$\nu_p$ $0.321 \pm 1.1 \cdot 10^{-7}$
$^{239}\text{Pu}$	(n,f)	$^{239}\text{Pu}$	(n,f) $0.295 \pm 2.6 \cdot 10^{-7}$
$^{239}\text{Pu}$	$\chi$	$^{239}\text{Pu}$	$\chi$ $0.261 \pm 2.0 \cdot 10^{-6}$
$^{240}\text{Pu}$	(n, $\gamma$ )	$^{240}\text{Pu}$	(n, $\gamma$ ) $0.197 \pm 2.3 \cdot 10^{-8}$
$^{239}\text{Pu}$	(n,f)	$^{239}\text{Pu}$	(n, $\gamma$ ) $0.174 \pm 4.3 \cdot 10^{-8}$
$^{238}\text{U}$	(n, $\gamma$ )	$^{238}\text{U}$	(n, $\gamma$ ) $0.167 \pm 3.6 \cdot 10^{-8}$
$^{239}\text{Pu}$	(n, $\gamma$ )	$^{239}\text{Pu}$	(n, $\gamma$ ) $0.151 \pm 6.7 \cdot 10^{-8}$
$^{238}\text{U}$	(n,n')	$^{238}\text{U}$	(n,f) $-0.138 \pm 5.6 \cdot 10^{-7}$
<b>Total uncertainty in <math>k_{eff}</math></b>		<b><math>0.772 \pm 3.7 \cdot 10^{-6}</math></b>	

Sensitivities and uncertainties are being converted to SG33 format



- R-Z model developed
- **Based on WPRS SFR-UAM**
- Dimensions and materials provided in an Excel spreadsheet
- **Sent to M. Fleming (21/11/2019)**

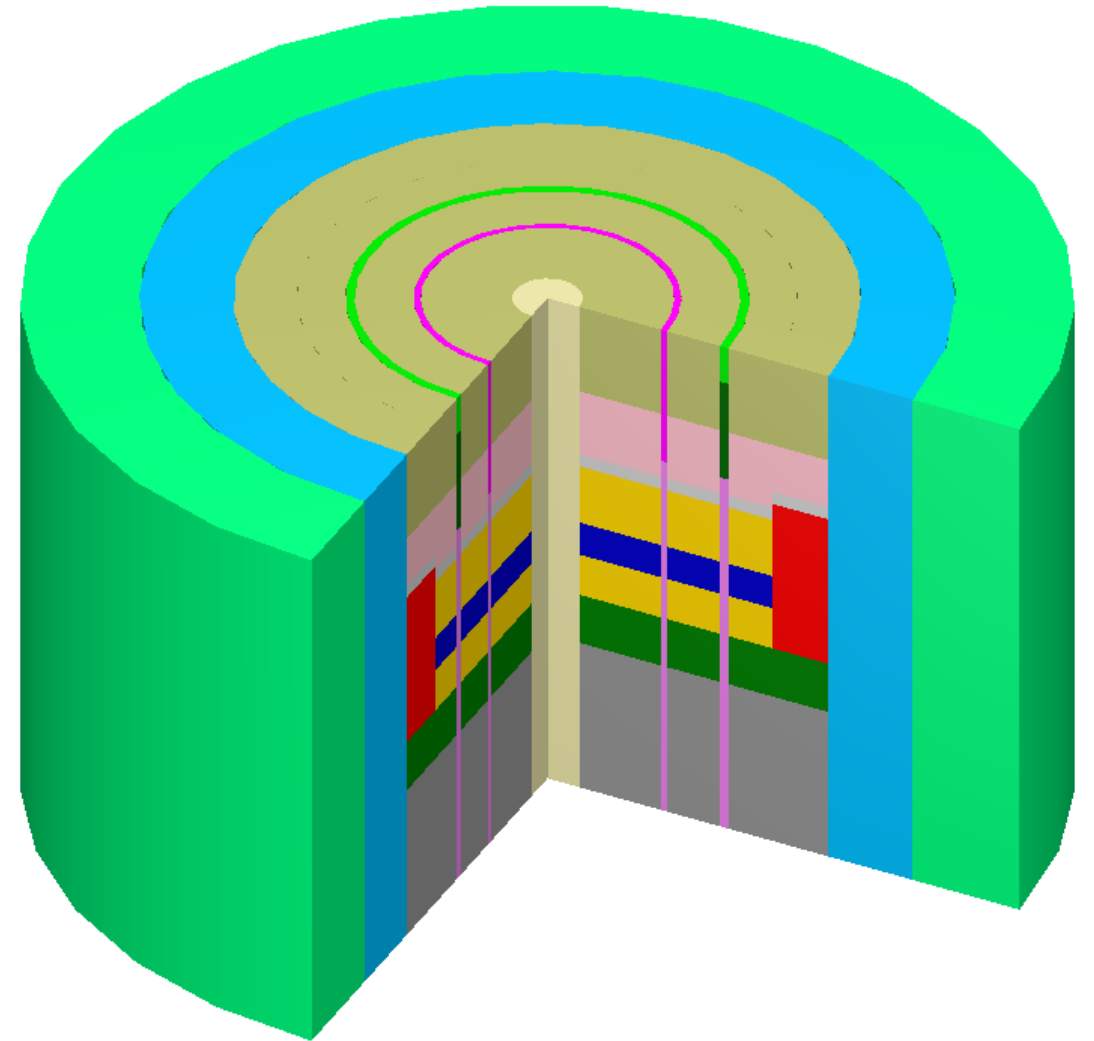



- **S/U analyses performed** with SCALE6.1.3 and ENDF/B-VII.0 for  $k_{eff}$  and 7 voiding scenarios

$k_{eff}$  integrated sensitivity coefficients  $\left( \frac{\Delta k/k}{\Delta \Sigma/\Sigma} \right)$

	Heterogeneous	Homogeneous	R-Z
$^{239}\text{Pu}$ nubar	6.71E-01±7E-6	6.73E-01±7E-6	6.72E-01±7E-6
$^{239}\text{Pu}$ fission	4.90E-01±3E-5	4.93E-01±3E-5	4.90E-01±3E-5
$^{238}\text{U}$ (n,γ)	-2.01E-01±4E-5	-2.01E-01±3E-5	-2.01E-01±3E-5
$^{238}\text{U}$ nubar	1.19E-01±3E-6	1.17E-01±3E-6	1.17E-01±3E-6
$^{241}\text{Pu}$ nubar	9.30E-02±1E-6	9.36E-02±1E-6	9.34E-02±1E-6
$^{240}\text{Pu}$ nubar	7.29E-02±1E-6	7.26E-02±1E-6	7.33E-02±1E-6
$^{238}\text{U}$ fission	7.22E-02±1E-5	7.12E-02±1E-5	7.01E-02±1E-5
$^{241}\text{Pu}$ fission	6.83E-02±5E-6	6.91E-02±5E-6	6.86E-02±5E-6
$^{238}\text{U}$ (n,n')	-5.89E-02±1E-4	-5.75E-02±1E-4	-6.00E-02±1E-4
$^{239}\text{Pu}$ (n,γ)	-4.92E-02±9E-6	-4.88E-02±9E-6	-4.81E-02±9E-6
$^{16}\text{O}$ elastic	-4.43E-02±8E-4	-4.34E-02±7E-4	-4.79E-02±8E-4
$^{23}\text{Na}$ elastic	1.02E-02±3E-4	5.50E-03±3E-4	4.12E-03±3E-4
$^{56}\text{Fe}$ (n,n')	-1.92E-02±6E-5	-2.07E-02±5E-5	-2.06E-02±5E-5



- **S/U analyses performed** with SCALE6.1.3 and ENDF/B-VII.0 for  $k_{eff}$  and 7 voiding scenarios

$k_{eff}$  integrated sensitivity coefficients  $\left(\frac{\Delta k/k}{\Delta \Sigma/\Sigma}\right)$

	Heterogeneous	Homogeneous	R-Z
$^{239}\text{Pu}$ nubar	6.71E-01±7E-6	6.73E-01±7E-6	6.72E-01±7E-6
$^{239}\text{Pu}$ fission	4.90E-01±3E-5	4.93E-01±3E-5	4.90E-01±3E-5
$^{238}\text{U}$ (n,γ)	-2.01E-01±4E-5	-2.01E-01±3E-5	-2.01E-01±3E-5
$^{238}\text{U}$ nubar	1.19E-01±3E-6	1.17E-01±3E-6	1.17E-01±3E-6
$^{241}\text{Pu}$ nubar	9.30E-02+1E-6	9.36E-02+1E-6	9.34E-02+1E-6
Differences <3% except for Na and Fe ( ~50% in Na ~ 7% in Fe)			
$^{238}\text{U}$ fission	7.22E-02±1E-5	7.12E-02±1E-5	7.01E-02±1E-5
$^{241}\text{Pu}$ fission	6.83E-02±5E-6	6.91E-02±5E-6	6.86E-02±5E-6
$^{238}\text{U}$ (n,n')	-5.89E-02±1E-4	-5.75E-02±1E-4	-6.00E-02±1E-4
$^{239}\text{Pu}$ (n,γ)	-4.92E-02±9E-6	-4.88E-02±9E-6	-4.81E-02±9E-6
$^{16}\text{O}$ elastic	-4.43E-02±8E-4	-4.34E-02±7E-4	-4.79E-02±8E-4
$^{23}\text{Na}$ elastic	1.02E-02+3E-4	5.50E-03+3E-4	4.12E-03+3E-4
$^{56}\text{Fe}$ (n,n')	-1.92E-02±6E-5	-2.07E-02±5E-5	-2.06E-02±5E-5



- Sensitivities of Na void worth for voiding scenarios for heterogenous model

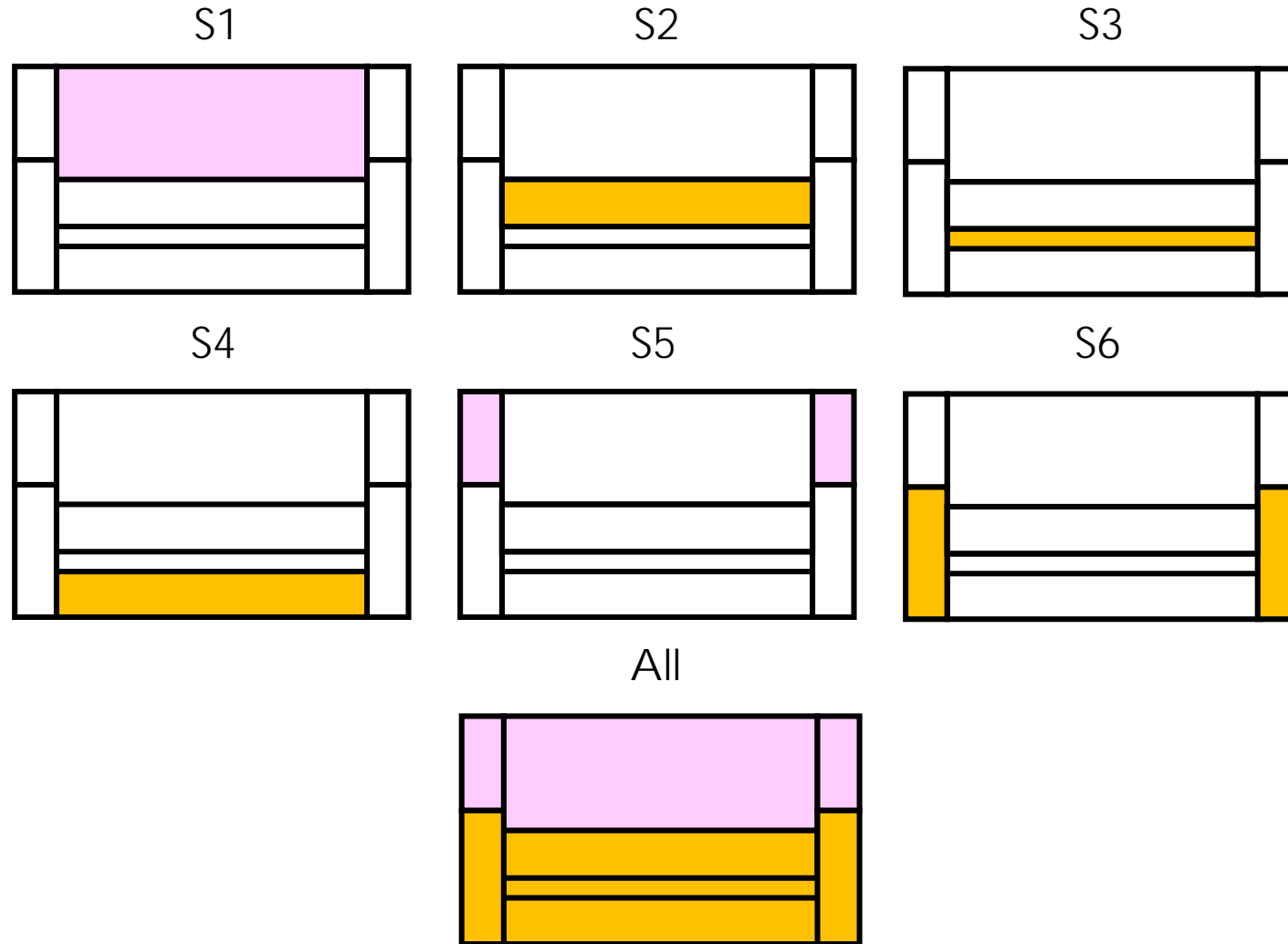



- Sensitivities of Na void worth for voiding scenarios for heterogenous model

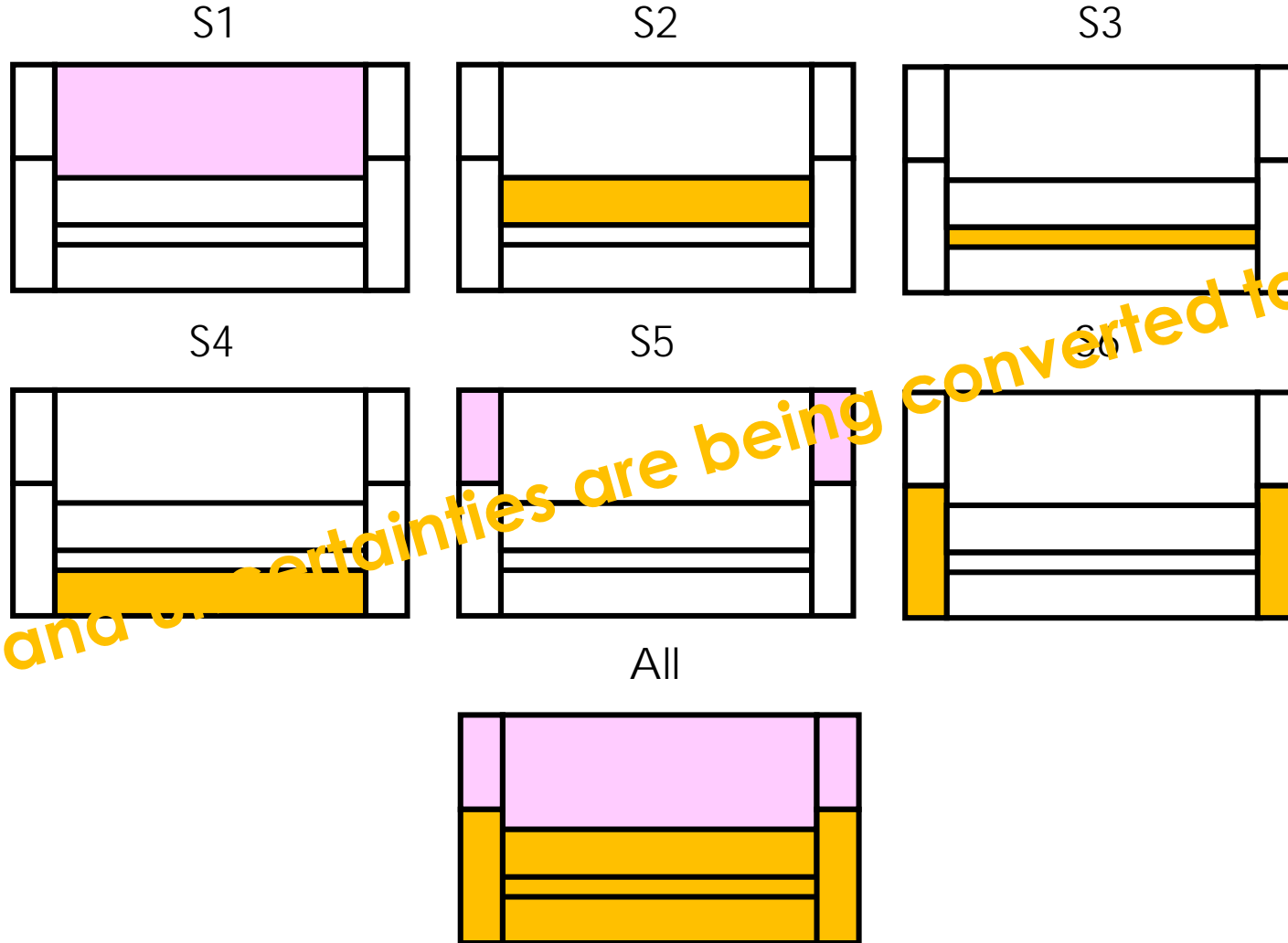

*Sensitivities and uncertainties are being converted to SG33 format*



- Sensitivities for voiding scenarios for heterogenous model

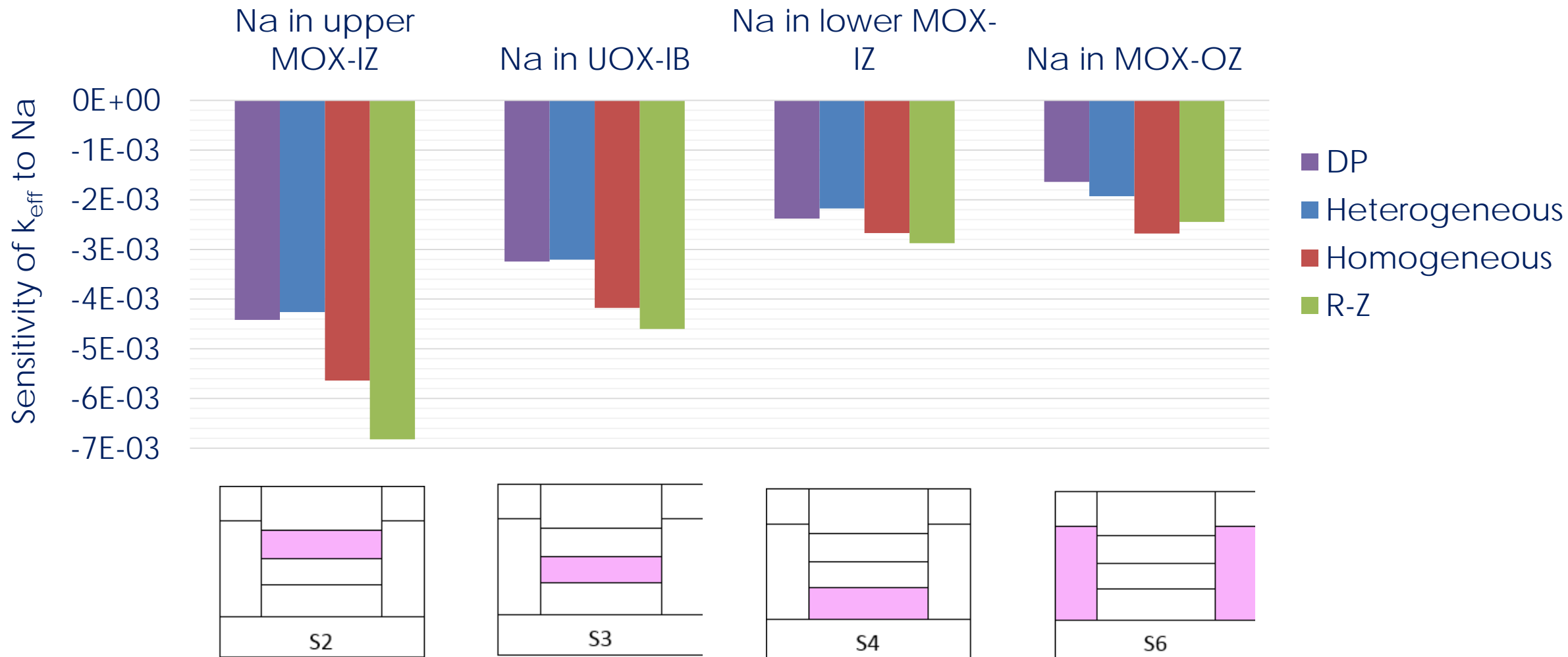



- Sensitivities for voiding scenarios for heterogenous model

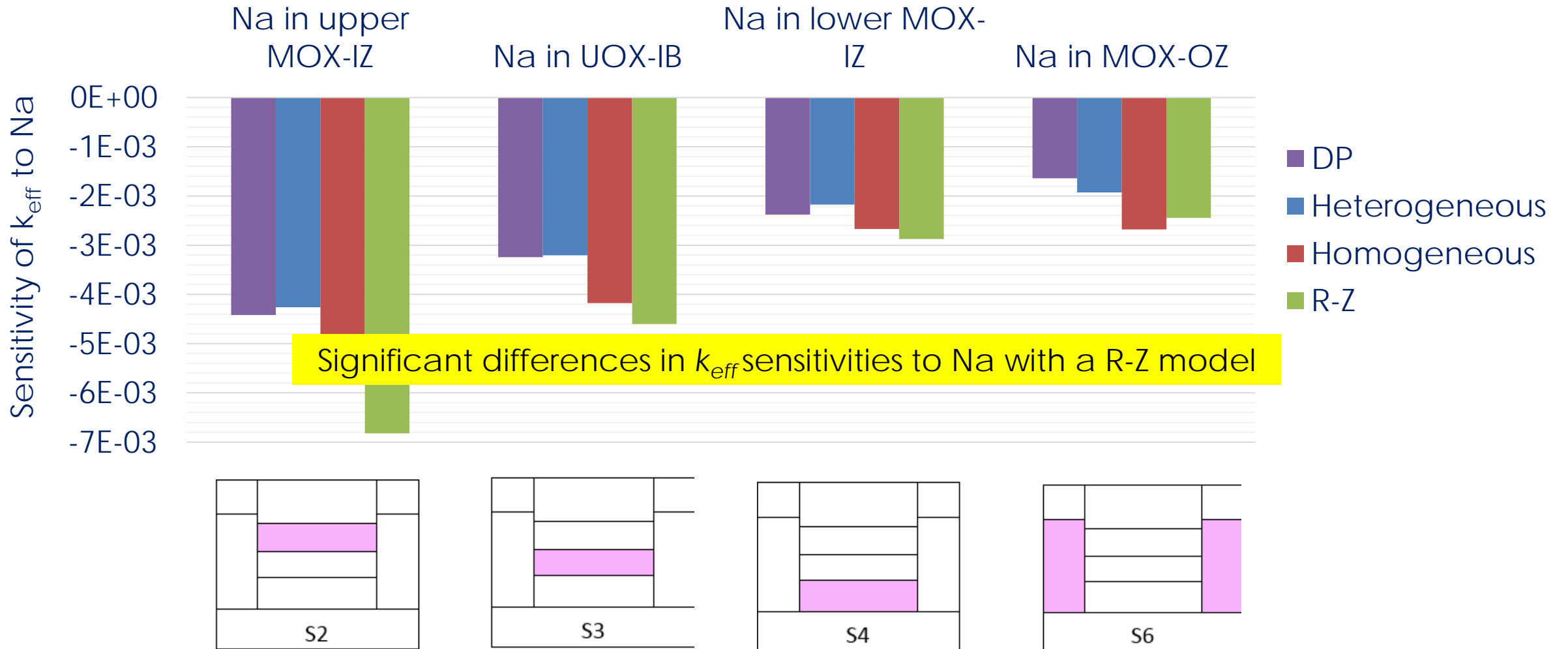



- Two 1200 MWth sodium-cooled FR cores:
  - TRU burner (1:20 MA:Pu ratio)
  - MA burner (1:2 MA:Pu ratio)
- Significant differences in kinetic (at EoC) and reactivity (at BoL) coefficients\*:
  - Original ASTRID:  $\beta_{eff} = 356$  pcm,  $\Lambda_{eff} = 0.46$   $\mu$ s,  $K_D = -870$  pcm, SVRE = +2.2 \$
  - TRU burner:  $\beta_{eff} = 328$  pcm,  $\Lambda_{eff} = 0.63$   $\mu$ s,  $K_D = -571$  pcm, SVRE = +3.1 \$
  - MA burner:  $\beta_{eff} = 272$  pcm,  $\Lambda_{eff} = 0.47$   $\mu$ s,  $K_D = -275$  pcm, SVRE = +5.9 \$

\*F. Gabrielli et al. *Energy Procedia* 71 (2015) 130-139



- Two 1200 MWth sodium-cooled FR cores:
  - TRU burner (1:20 MA:Pu ratio)
  - MA burner (1:2 MA:Pu ratio)
- Significant differences in kinetic (at EoC) and reactivity (at BoL) coefficients\*:
  - Original ASTRID:  $\beta_{eff} = 356$  pcm,  $\Lambda_{eff} = 0.46$   $\mu$ s,  $K_D = -870$  pcm, SVRE = +2.2 \$
  - TRU burner:  $\beta_{eff} = 328$  pcm,  $\Lambda_{eff} = 0.63$   $\mu$ s,  $K_D = -571$  pcm, SVRE = +3.1 \$
  - MA burner:  $\beta_{eff} = 272$  pcm,  $\Lambda_{eff} = 0.47$   $\mu$ s,  $K_D = -275$  pcm, SVRE = +5.9 \$

\*F. Gabrielli et al. Energy Procedia 71 (2015) 130-139

## Nuclear data uncertainties should significantly differ



- Two 1200 MWth sodium-cooled FR cores:
  - TRU burner (1:20 MA:Pu ratio)
  - MA burner (1:2 MA:Pu ratio)
- Significant differences in kinetic (at EoC) and reactivity (at BoL) coefficients\*:
  - Original ASTRID:  $\beta_{eff} = 356$  pcm,  $\Lambda_{eff} = 0.46$   $\mu$ s,  $K_D = -870$  pcm, SVRE = +2.2 \$
  - TRU burner:  $\beta_{eff} = 328$  pcm,  $\Lambda_{eff} = 0.63$   $\mu$ s,  $K_D = -571$  pcm, SVRE = +3.1 \$
  - MA burner:  $\beta_{eff} = 272$  pcm,  $\Lambda_{eff} = 0.47$   $\mu$ s,  $K_D = -275$  pcm, SVRE = +5.9 \$

Modelling details?

\*F. Gabrielli et al. Energy Procedia 71 (2015) 130-139

## Nuclear data uncertainties should significantly differ



- Three sodium-cooled FR cores:
  - 3600 MWth MOX core
  - 1000 MWth MET core
  - **ASTRID-like core**

3600 MWth MOX Unc. k			1000 MWth MET Unc. k		
<i>input</i>	<i>ranking</i>	<i>value</i>	<i>input</i>	<i>ranking</i>	<i>value</i>
4_238U	1	0.488	4_238U	1	0.542
18_240Pu	2	0.378	18_240Pu	2	0.387
18_239Pu	3	0.352	18_239Pu	3	0.312
1018_239Pu	4	0.253	102_238U	4	0.256
102_238U	5	0.251	1018_239Pu	5	0.213
Results from L. Buiron for SFR-UAM benchmark					
3600 MWth MOX Unc. K <sub>D</sub>			1000 MWth MET Unc. K <sub>D</sub>		
<i>input</i>	<i>ranking</i>	<i>value</i>	<i>input</i>	<i>ranking</i>	<i>value</i>
4_238U	1	1.896	4_238U	1	3.001
18_240Pu	2	1.451	18_240Pu	2	1.632
102_239Pu	3	1.111	2_56Fe	3	1.261
18_239Pu	4	1.104	18_239Pu	4	1.050
2_160	5	0.847	102_240Pu	5	1.047
Results from L. Buiron for SFR-UAM benchmark					
3600 MWth MOX Unc. SVRE			1000 MWth MET Unc. SVRE		
<i>input</i>	<i>ranking</i>	<i>value</i>	<i>input</i>	<i>ranking</i>	<i>value</i>
18_239Pu	1	2.200	102_238U	1	0.924
4_Na23	2	1.566	18_239Pu	2	0.774
4_238U	3	1.005	18_240Pu	3	0.565
102_238U	4	0.992	1018_239Pu	4	0.314
102_239Pu	5	0.658	102_56Fe	5	0.267



- Three sodium-cooled FR cores:
  - 3600 MWth MOX core
  - 1000 MWth MET core
  - **ASTRID-like core**

**Preliminary  
assessment:  
include MET core**

3600 MWth MOX Unc. k			1000 MWth MET Unc. k		
<i>input</i>	<i>ranking</i>	<i>value</i>	<i>input</i>	<i>ranking</i>	<i>value</i>
4_238U	1	0.488	4_238U	1	0.542
18_240Pu	2	0.378	18_240Pu	2	0.387
18_239Pu	3	0.352	18_239Pu	3	0.312
1018_239Pu	4	0.253	102_238U	4	0.256
102_238U	5	0.251	1018_239Pu	5	0.213
Results from L. Buiron for SFR-UAM benchmark					
3600 MWth MOX Unc. K <sub>D</sub>			1000 MWth MET Unc. K <sub>D</sub>		
<i>input</i>	<i>ranking</i>	<i>value</i>	<i>input</i>	<i>ranking</i>	<i>value</i>
4_238U	1	1.896	4_238U	1	3.001
18_240Pu	2	1.451	18_240Pu	2	1.632
102_239Pu	3	1.111	2_56Fe	3	1.261
18_239Pu	4	1.104	18_239Pu	4	1.050
2_160	5	0.847	102_240Pu	5	1.047
Results from L. Buiron for SFR-UAM benchmark					
3600 MWth MOX Unc. SVRE			1000 MWth MET Unc. SVRE		
<i>input</i>	<i>ranking</i>	<i>value</i>	<i>input</i>	<i>ranking</i>	<i>value</i>
18_239Pu	1	2.200	102_238U	1	0.924
4_Na23	2	1.566	18_239Pu	2	0.774
4_238U	3	1.005	18_240Pu	3	0.565
102_238U	4	0.992	1018_239Pu	4	0.314
102_239Pu	5	0.658	102_56Fe	5	0.267



- MYRRHA and ASTRID R-Z models have been developed
- MYRRHA and ASTRID sensitivities and uncertainties are being converted to SG33 format
- Recommendation to employ detailed models for reactivity effects
- Recommendation to include ASTRID-like TRU burner and MA burner
- Preliminary assessment to include MET core from SFR-UAM