



Measurements of sodium inelastic scattering and deuterium elastic scattering

Arjan Plompen

Overview

- *Na inelastic scattering with GAINS*
C. Rouki et al., Nucl. Instrum. Meth. A 672 (2012) 82
- *Na elastic and inelastic scattering with eight liquid scintillators*
S. Kopecky and A. Plompen "R-matrix analysis of the total and inelastic scattering cross sections" EUR 25067 EN (LANA-25067-EN-N.pdf)
- *Deuterium elastic scattering with Li-glass detectors at nELBE (in progress)*



NEA HPRL for nuclear data

www.nea.fr/html/dbdata/hprial/

NEA Nuclear Data High Priority

Request ID	29		Status of the request	High Priority request	
Target	Reaction and process	Incident Energy	Secondary energy or angle	Target uncertainty	Covariance
11-NA-23	(n,inl) SIG	0.5 MeV-1.3 MeV	Emis spec.	See details	Y
Field	Subfield	Date Request created	Date Request accepted	Ongoing action	
Fission	Fast Reactors (SFR)	04-APR-08	12-SEP-08		

1. High priority request
2. General request

Energy Range	Target versus initial uncertainties (%)			
	Initial	ABTR	SFR	EFR
1.35 - 2.23 MeV	13		9	
0.498 - 1.35 MeV	28	10	4	8

ity
SIG
SIG
prod
prod
SIG
SIG
,DDX
A/dE
SIG
SIG
lpha
, RP
SIG
SIG
SIG
SIG

H 15 95-AM-241 (n,g), (n, tot)
(n, f) n spectrum
(n, f) n spectrum
(n, inl) SIG
(n, f) SIG
(n, f) SIG
(n, f) SIG
(n, f) SIG
(n, f) SIG



GAINS @ FP3/200m

GELINA

Angle integration

Exact angle integration $1 \leq L \leq 3$

$$\frac{d\sigma}{d\Omega}(\theta) = \frac{\sigma}{4\pi} W(\theta) = \frac{\sigma}{4\pi} \sum_{k=0}^{k_{\max}} c_{2k} P_{2k}(\cos(\theta))$$

$$\sigma = 2\pi \int_{-1}^1 \frac{d\sigma}{d\Omega}(x) dx = 2\pi \sum_{i=1}^2 w_i \frac{d\sigma}{d\Omega}(x_i)$$

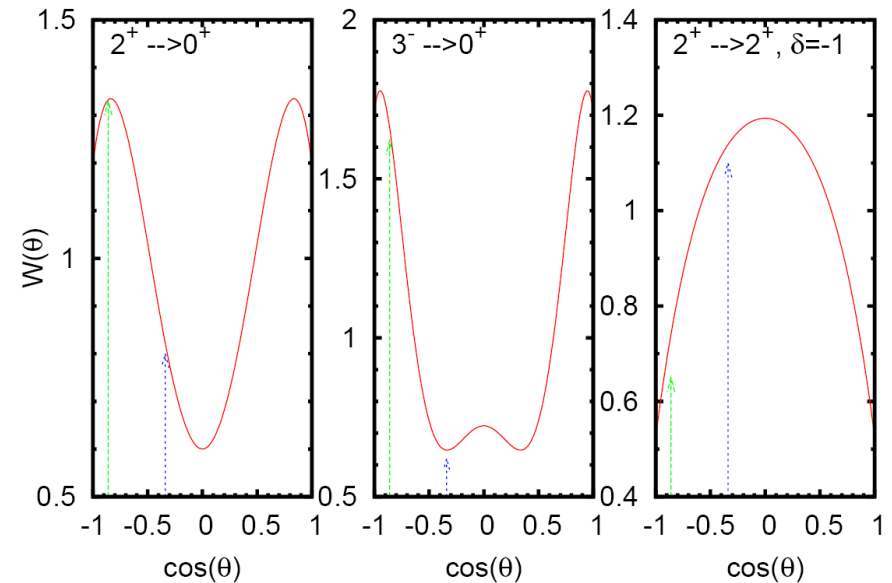

$$x_i = \cos(\theta_i)$$

$$\begin{aligned} \theta_1 = 110^\circ, 70^\circ &\rightarrow w_1 = 1.30429 \\ \theta_2 = 150^\circ, 30^\circ &\rightarrow w_2 = 1.69571 \end{aligned}$$

Gamma efficiency determination

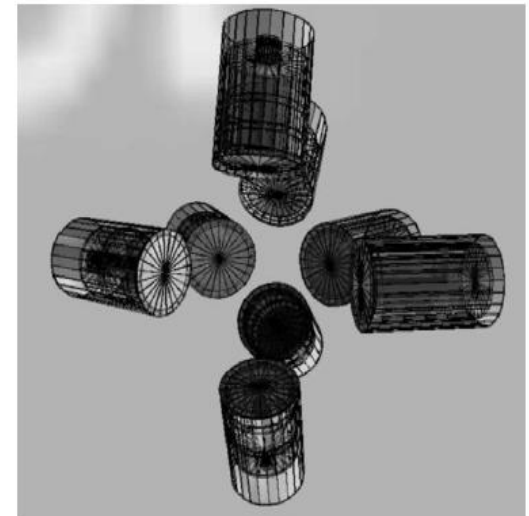
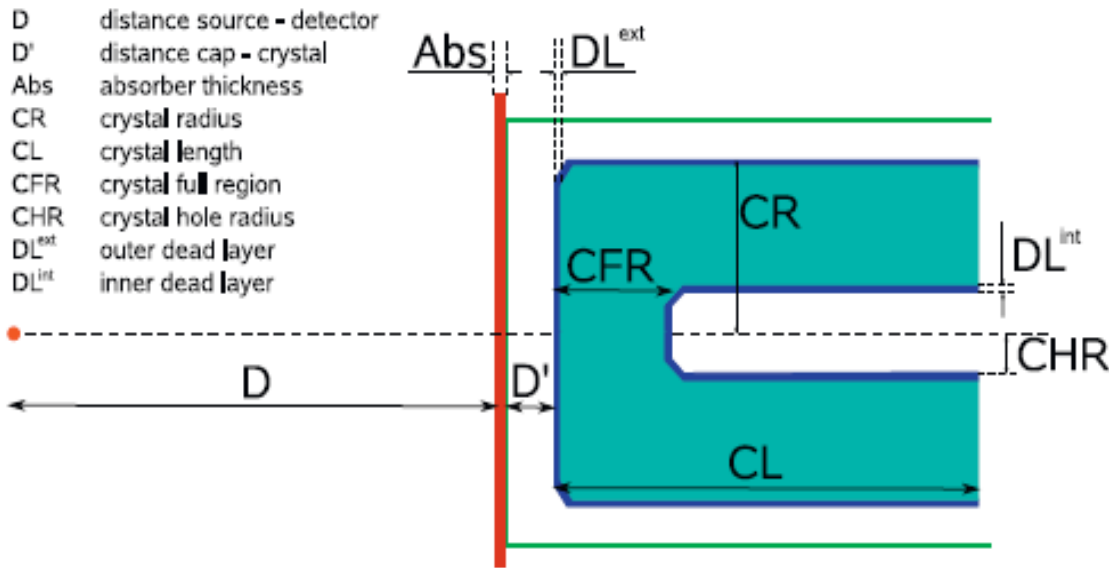

Fig. 1. GAINS. Drawing of the simulated geometry.

Fig. 2. Schematic drawing of a HPGe detector. The most important parameters are emphasized.

Large dependence on MC simulation

Point source calibration to model detector

Calculation for extended self-attenuating sample

Comparison of MCNP5 versus GEANT4

Neutron fluence determination

Neutron fluence monitoring: ^{235}U fission chamber

Revisiting of the fluence measurement

- Mass verified by alpha-counting
- Study of efficiency
- Control measurement at PTB (intercomparison)

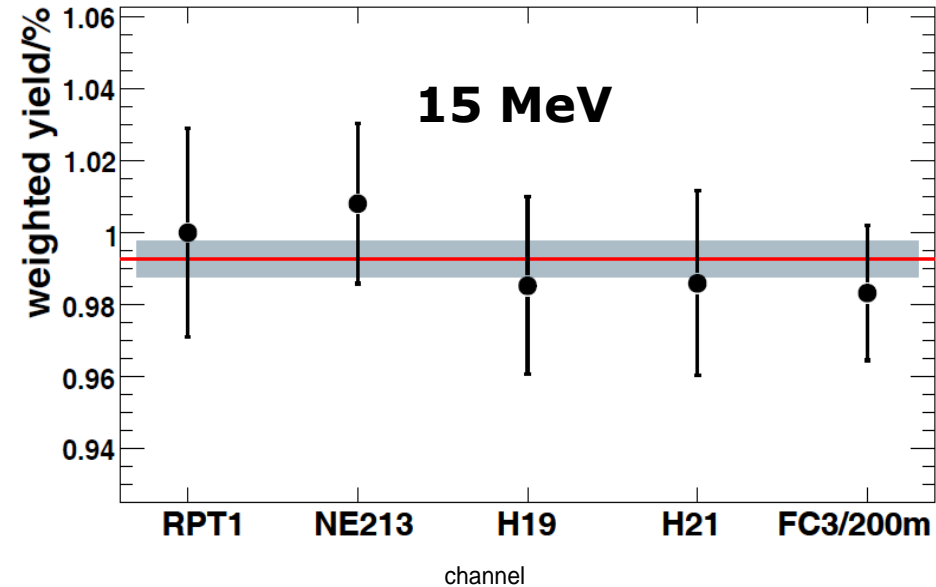
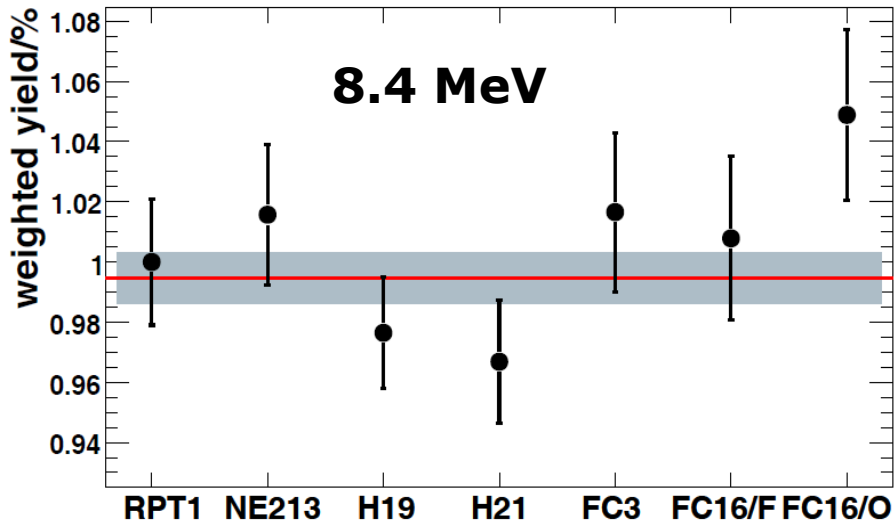
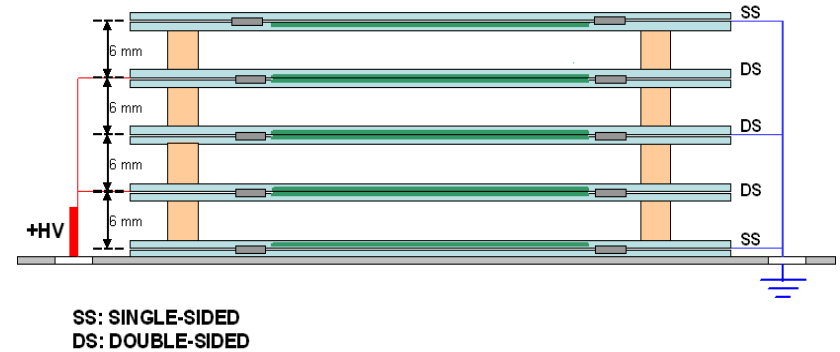

Observed transitions

- Upper limit of energy 3.84 MeV
- Total inelastic and level inelastic (relies on decay data)
- All statistics analysed
- Careful efficiency check gamma-ray detectors
- Final data delivered to CEA for benchmark testing
- Report EUR 24871 EN.
- Group cross section < 2.5 %!

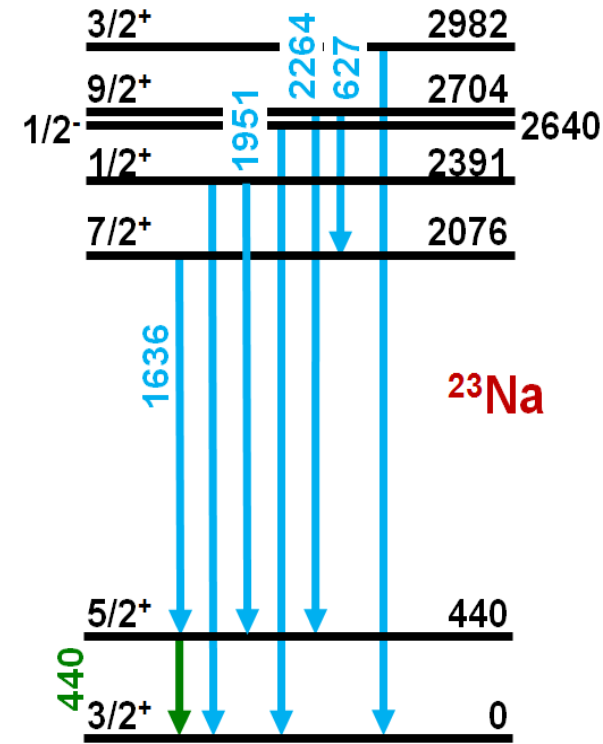

E_γ (keV)	E_{level1} (keV)	$J_{\pi1}$	$T_{1/2}$	E_{level2} (keV)	$J_{\pi2}$	I_γ	γ mult.
439.986(10)	439.990(9)	$5/2^+$	1.24(8) ps	0	$3/2^+$	100	M1+E2
1635.96(3)	2076.011(22)	$7/2^+$	24(2) fs	439.990(9)	$5/2^+$	100.00(14)	M1+E2
1950.652(21)	2390.732(13)	$1/2^+$	594(81) fs	439.990(9)	$5/2^+$	52.1(8)	E2
2390.599(18)	2390.732(13)	$1/2^+$	594(81) fs	0	$3/2^+$	100.0(6)	
2639.70(5)	2639.85(4)	$1/2^-$	58(11) fs	0	$3/2^+$	100	
2263.39(3)	2703.500(25)	$9/2^+$	95(4) fs	439.990(9)	$5/2^+$	100.0(9)	E2 (+M3)
2541.92(4)	2982.060(19)	$3/2^+$	2.5(4) fs	439.990(9)	$5/2^+$	70.1(3)	M1+E2

Table 1: Observed gammas from $^{23}\text{Na}(n,n'\gamma)$ and associated initial (1) and final (2) levels [10].

Inelastic versus other data and evaluations

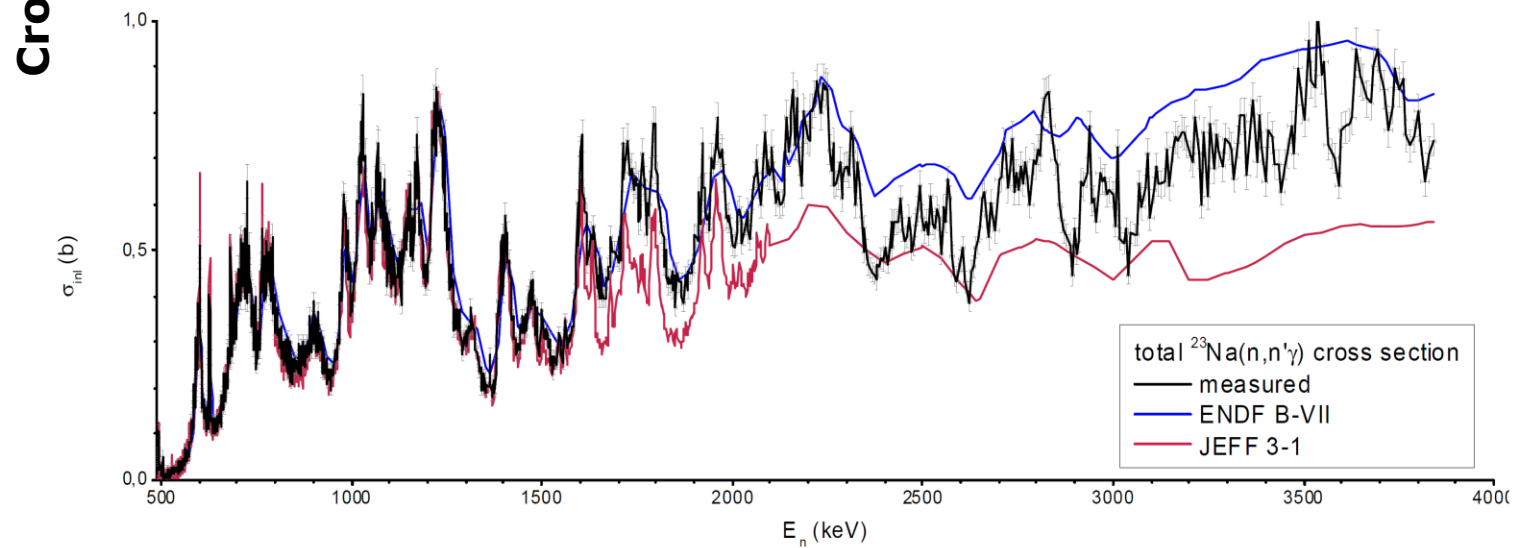
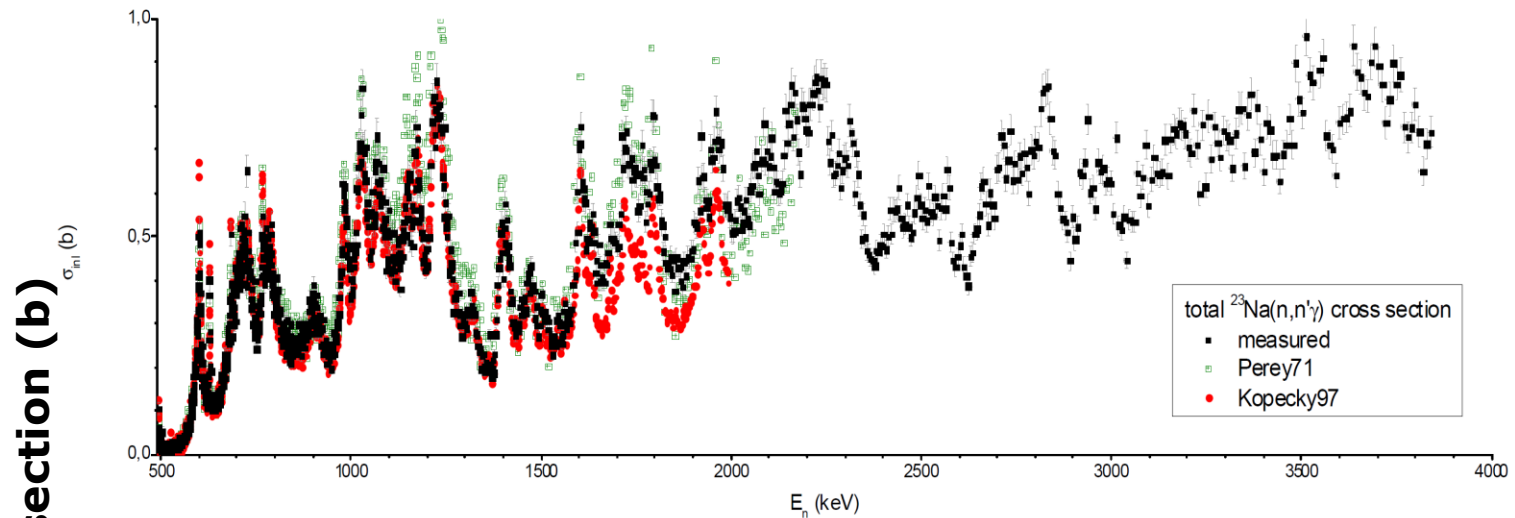

E_n (keV)

Level cross sections

Cross section (b)

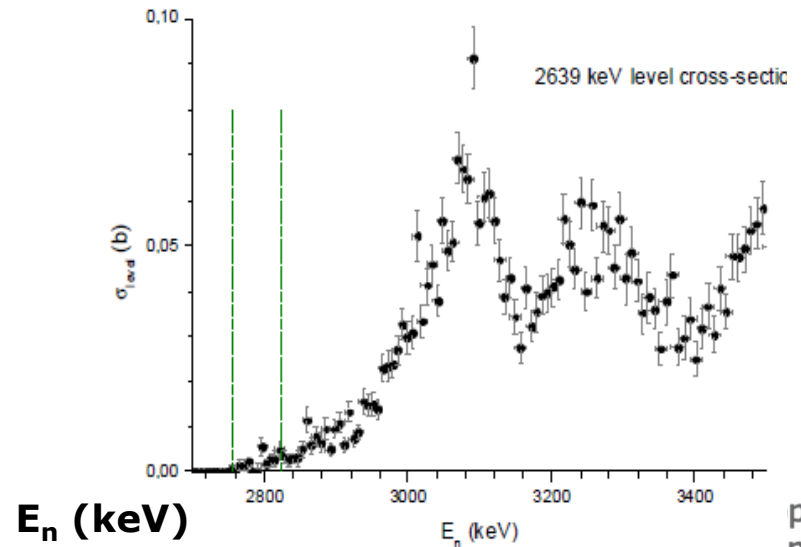
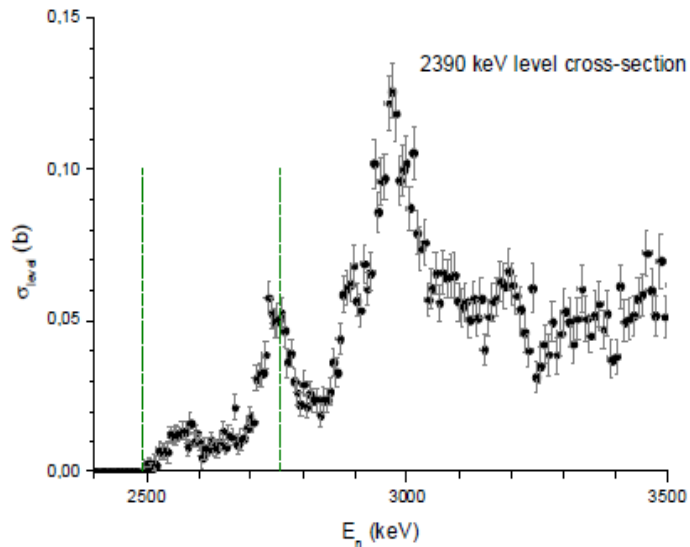
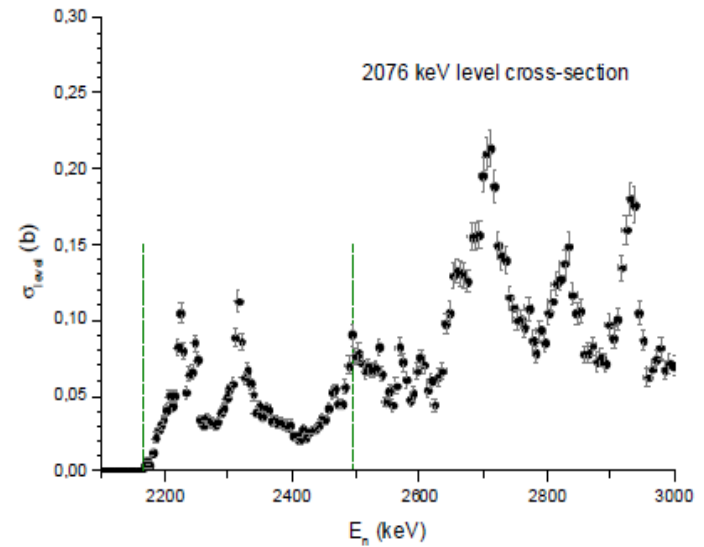
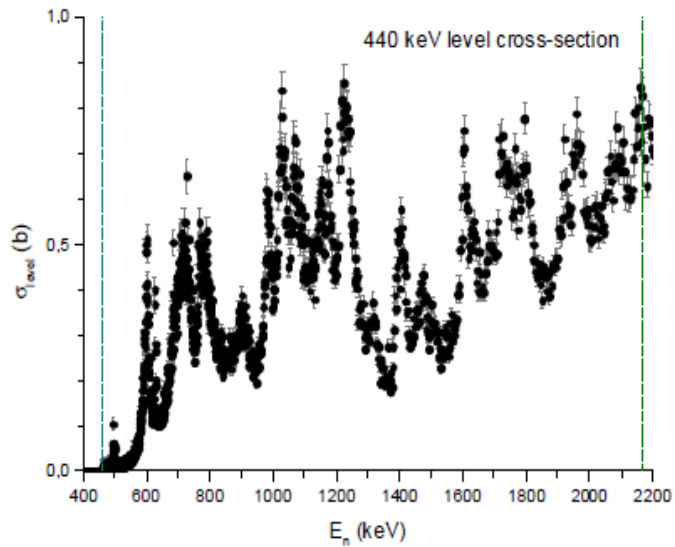

Conclusion

GAINS inelastic scattering

- *The GAINS measurements meet the HPRL target uncertainties derived from SG-26.*
- *GAINS data are not yet part of a new evaluation*
- *C. Rouki et al.,
Nucl. Instrum. Meth. A 672 (2012) 82*
- *Phys. Rev. C does not appreciate a good measurement*

Na elastic and inelastic scattering with eight liquid scintillators

- *H. Märten, J. Wartena and H. Weigmann, Simultaneous high resolution measurement of the differential elastic and inelastic neutron scattering cross section on selected light nuclei, GE/R/ND/02/1994 (1994), unpublished*
- *S. Kopecky, H. Märten, J. Wartena and H. Weigmann NDST, Triëste and EXFOR entry (1997), unpublished*
- *S. Kopecky and A. Plompen "R-matrix analysis of the total and inelastic scattering cross sections" EUR 25067 EN, LANA-25067-EN-N.pdf (2011)*

Overview

- *Measurements at GELINA in 1994, C, Na, Al, Fe*
- *Analysis using Blatt-Biedenharn and Multi-code*
- *Re-analysis S. Kopecky in 1994-1997 using SAMMY and compilation in EXFOR*
- *Provision of R-matrix parameters to CEA (2011)*
- *Analysis of the consistency of the combined elastic differential and inelastic data sets*
Angle integration and comparison with total xs (2011)

Setup

GELINA - White Neutron Source (800 Hz, 1 ns Pulse Width)

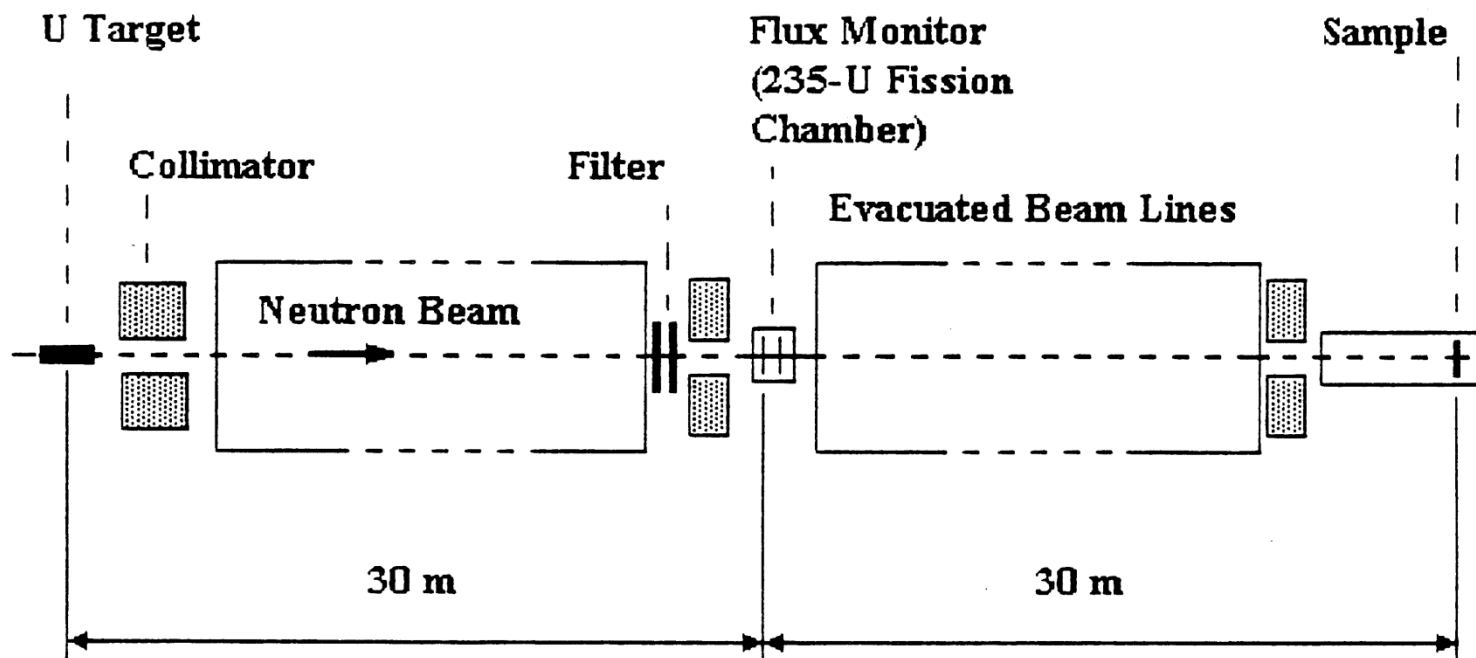

Setup

- 8x NE213
- 2"x2"ø
- Metal. Na
- v.s. $^{10}\text{B}(n, \alpha\text{g})$

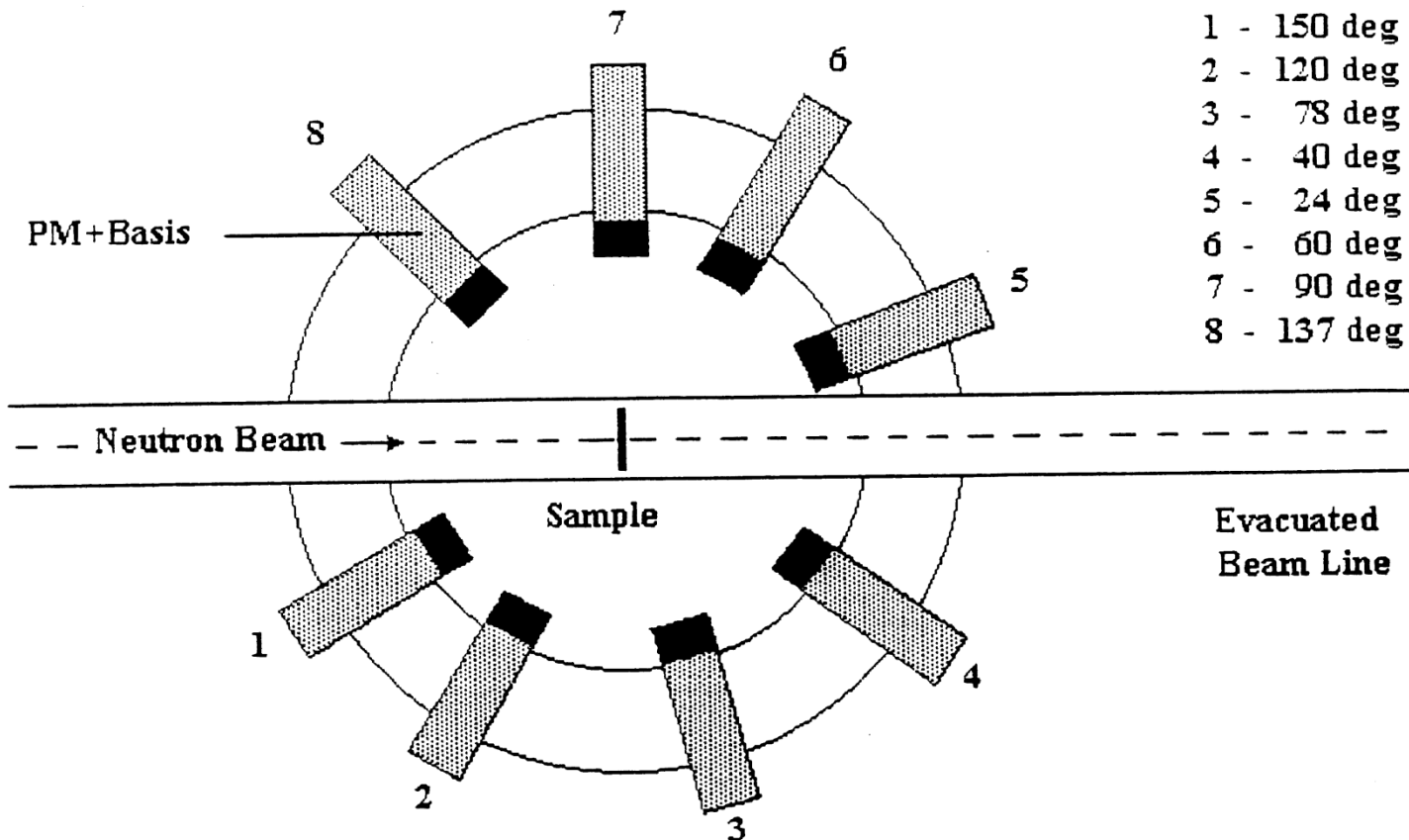

Flux

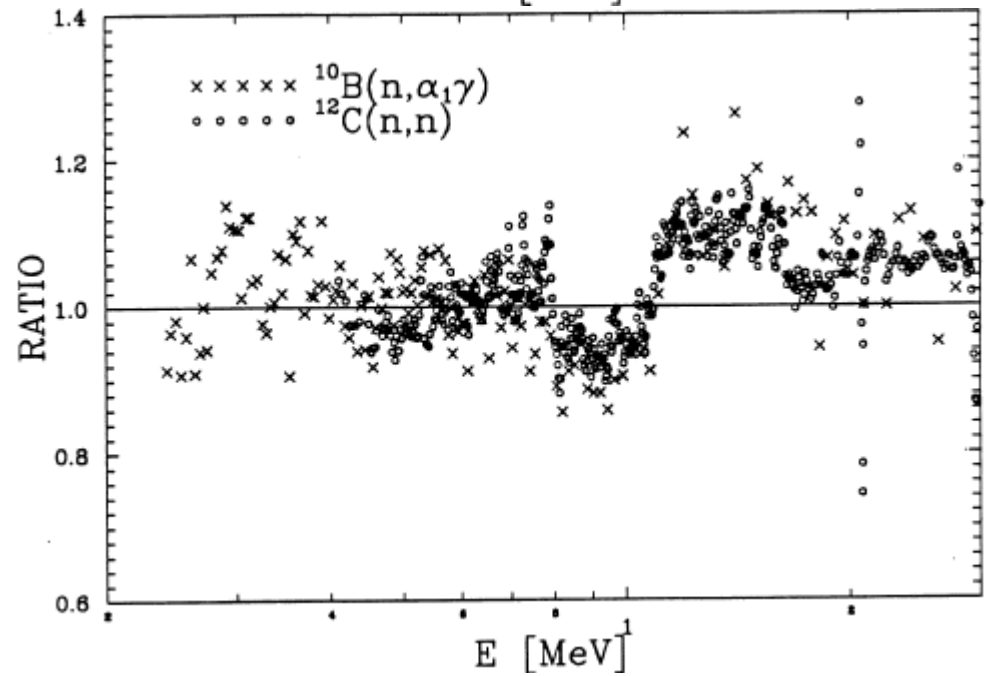
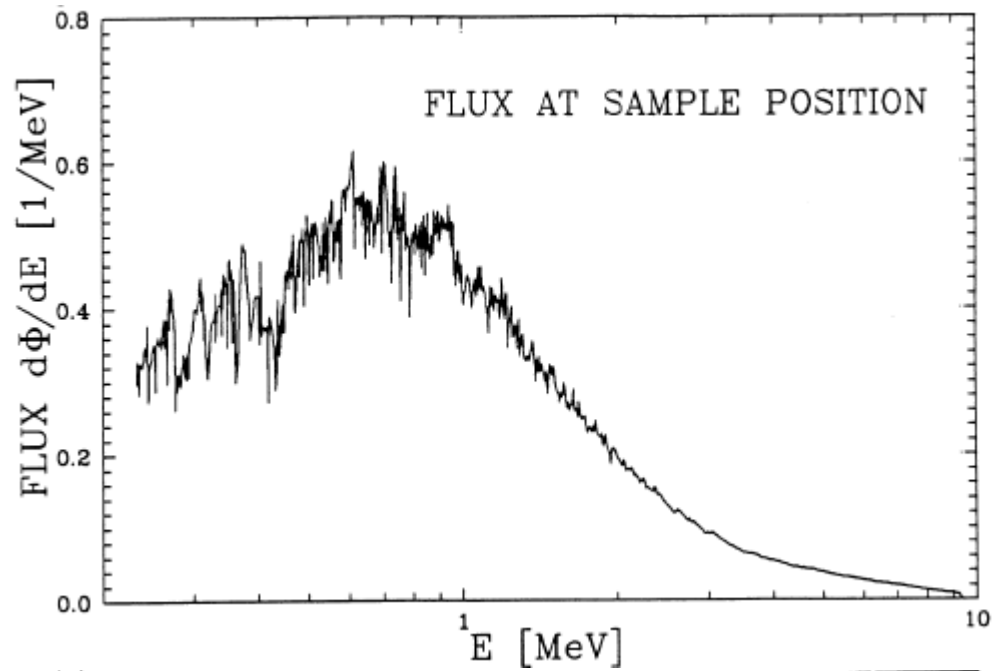

Response modeling required: n and g

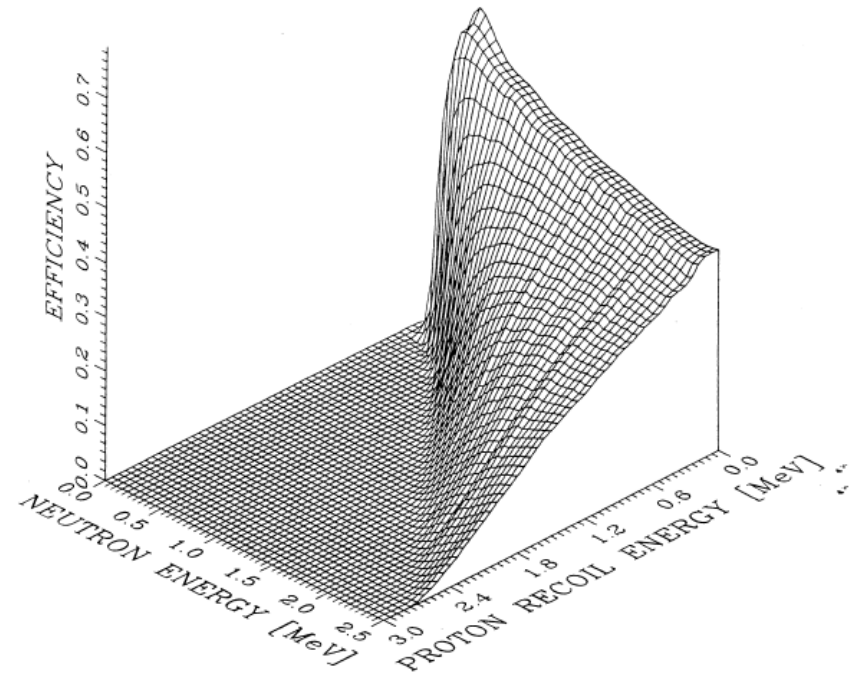
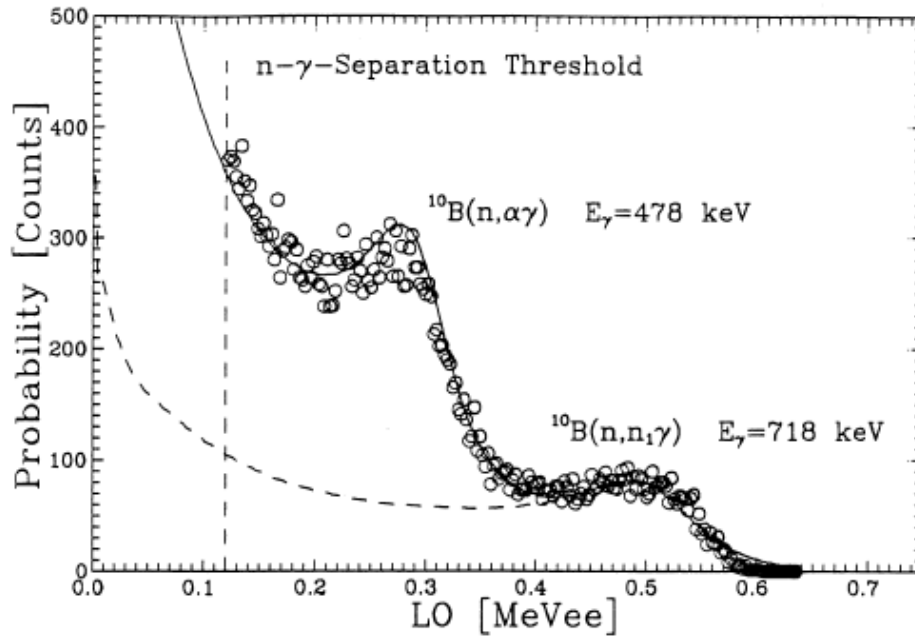

Further

- *Multiple scattering corrections*
- *Background subtraction*

Consistency check

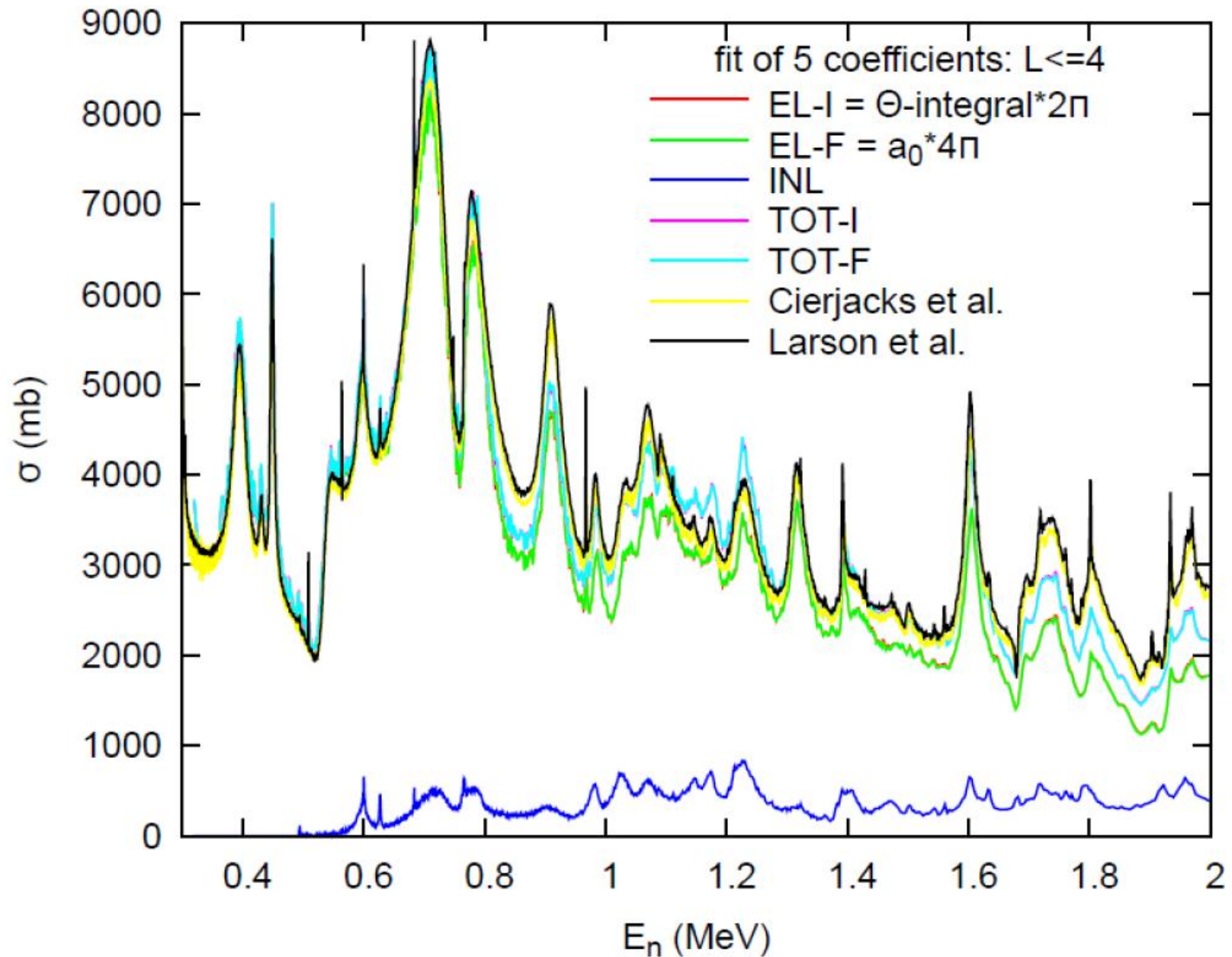

Legendre-fit to diff. xs.

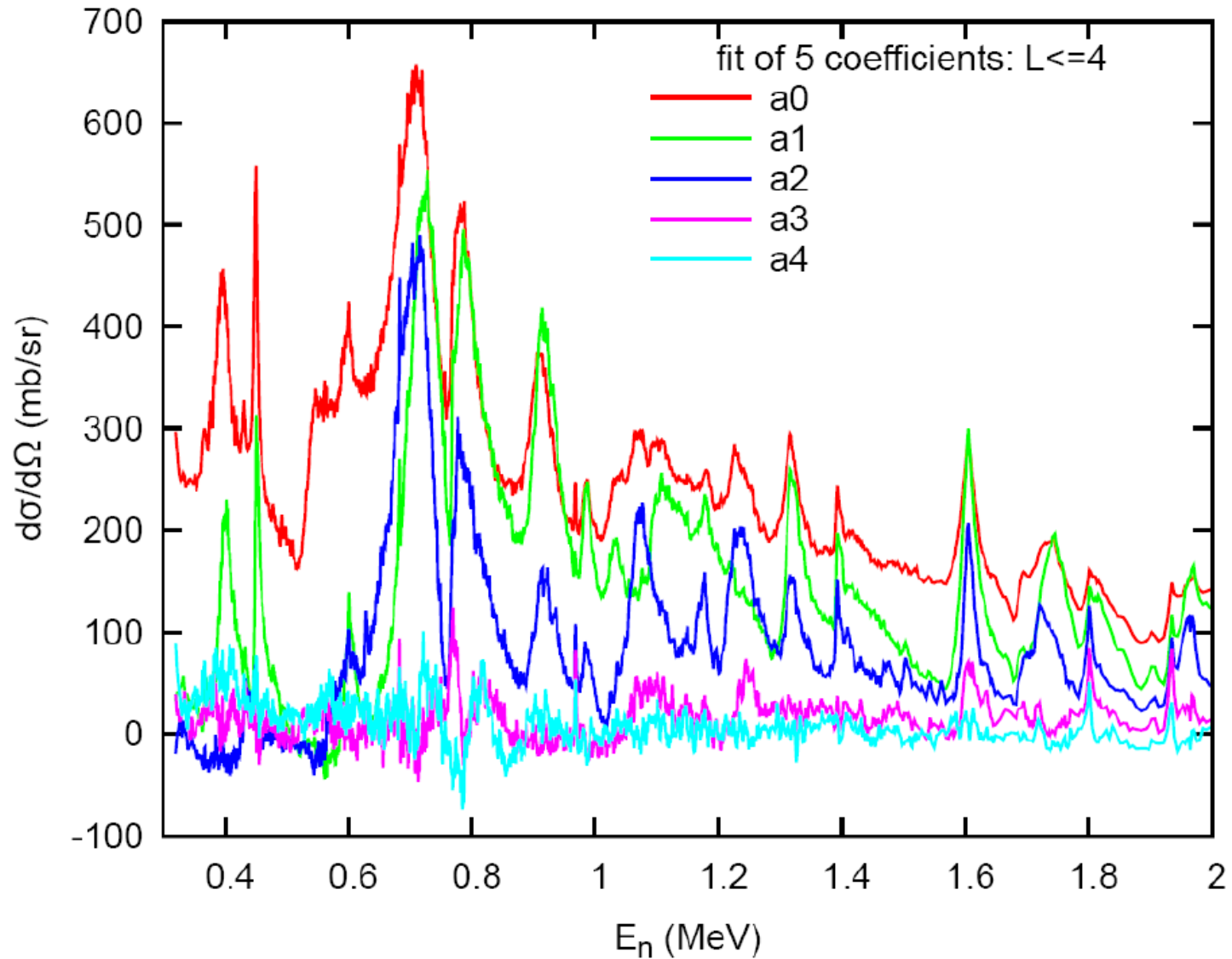

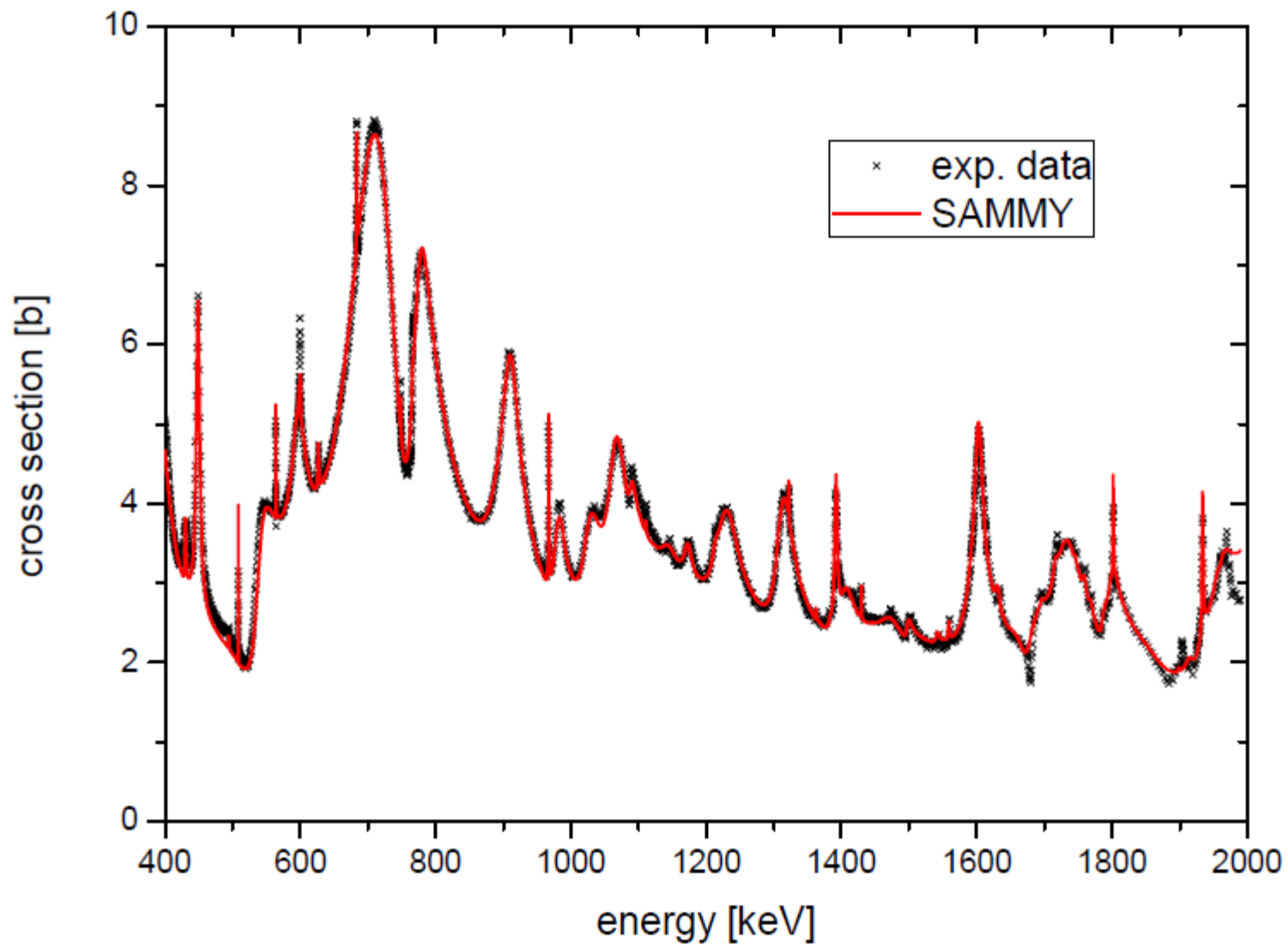

Fig 3: Comparison of experimental total cross section data of Larson et al. with calculation

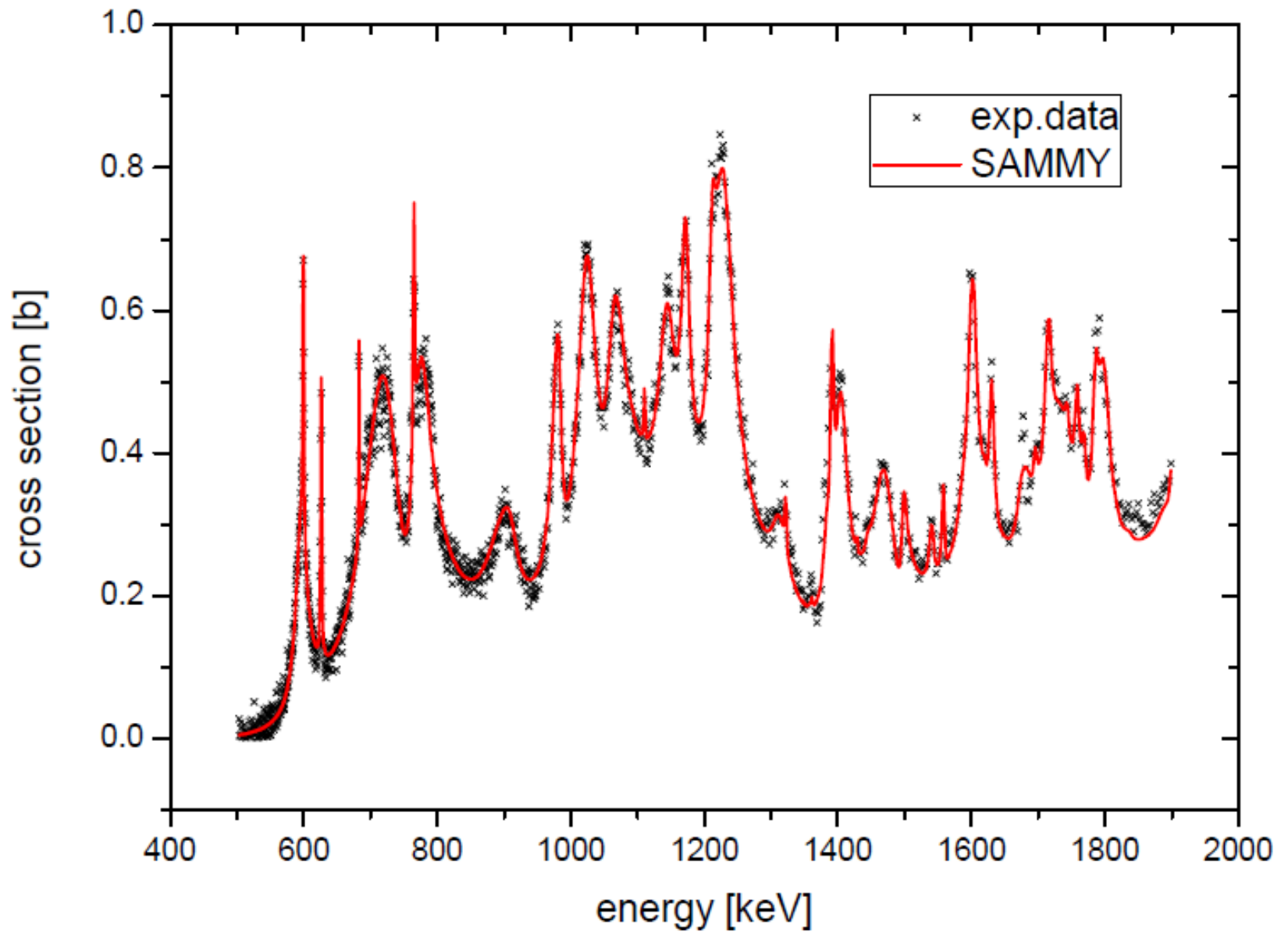

Fig 4: Comparison of experimental inelastic cross section data with calculation

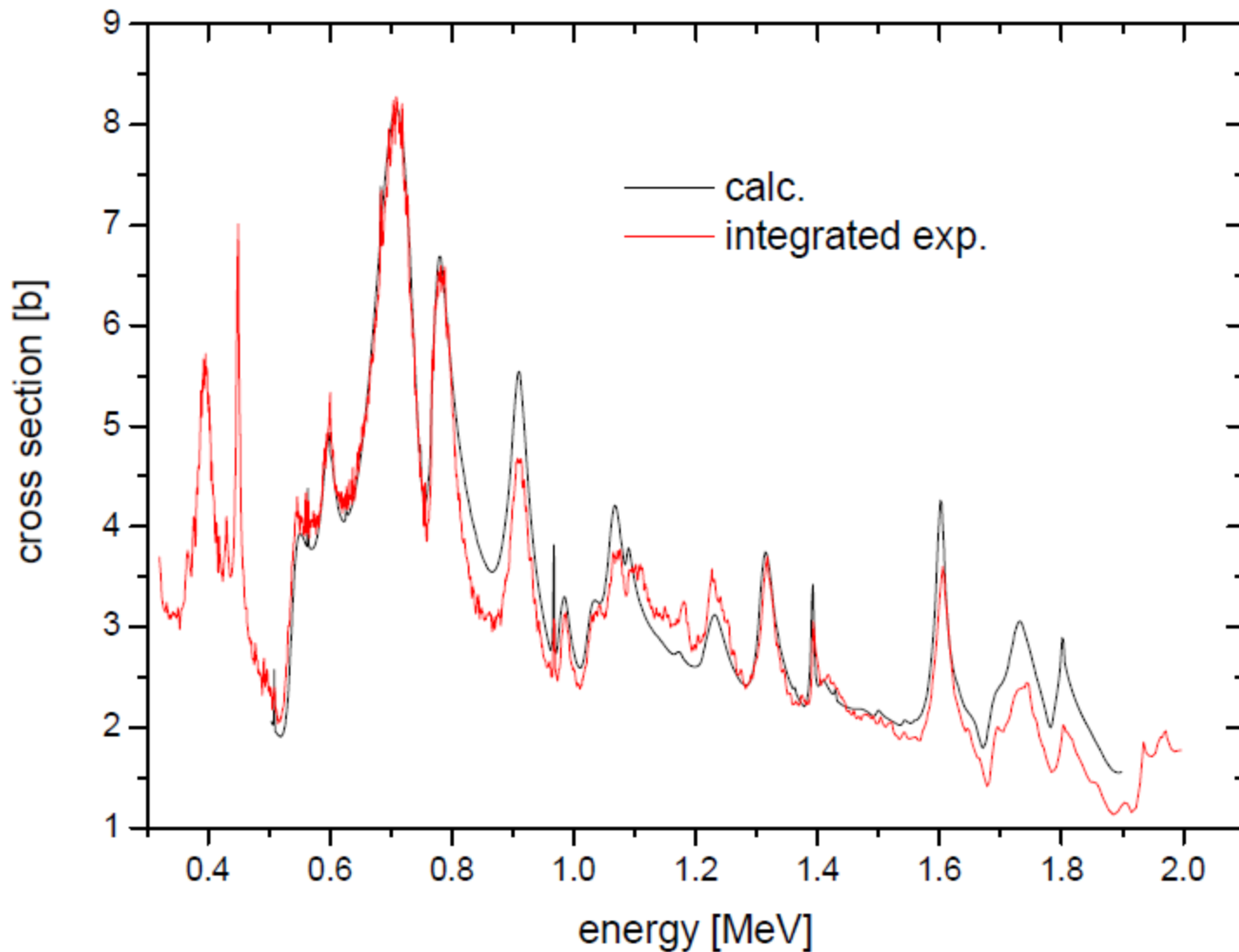

Fig 13: The elastic scattering cross section from the R-matrix calculation (calc.) and the Legendre fit to the experimental data (Integrated exp.).

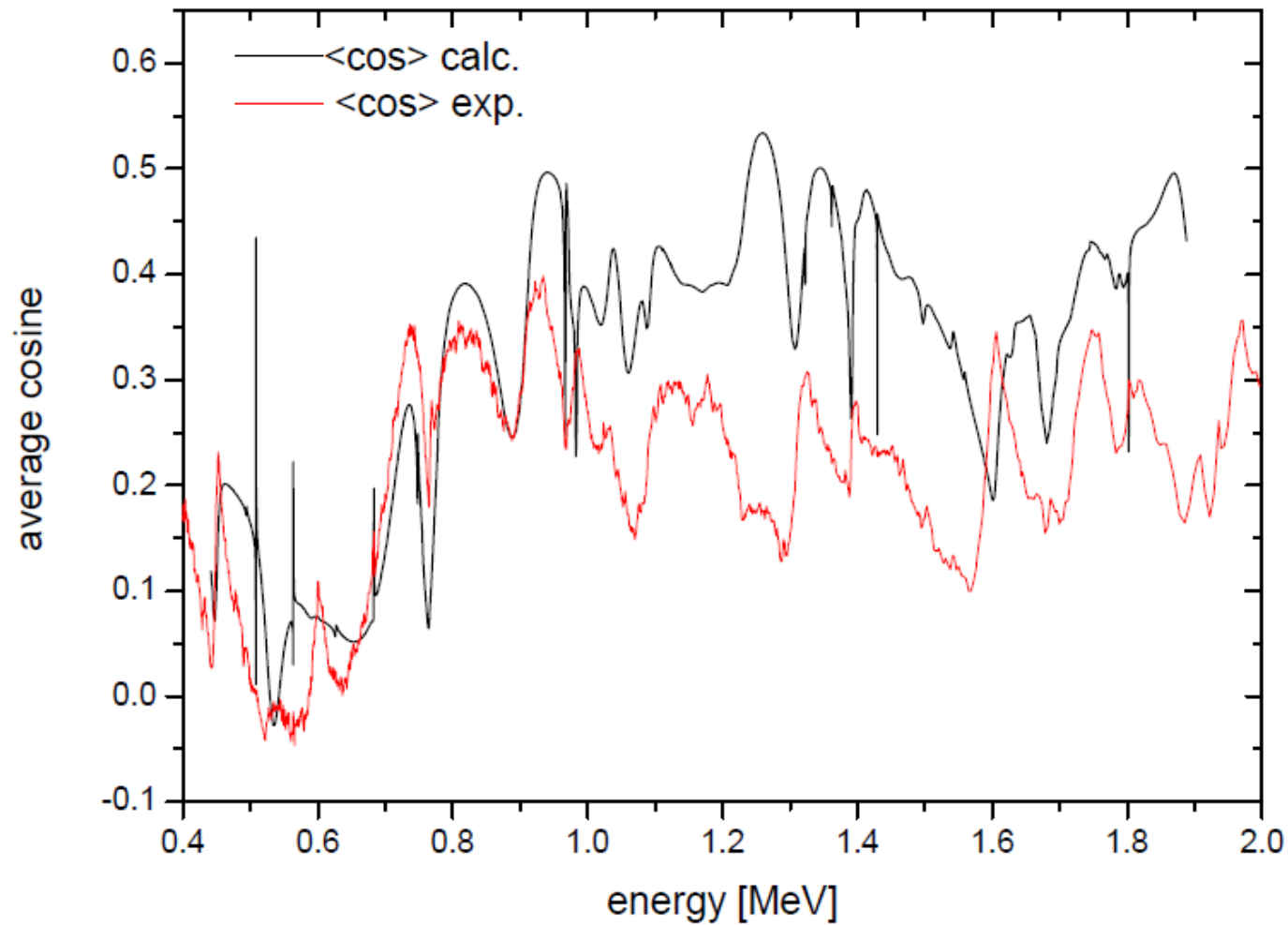

Fig 14: The centre of mass average cosine from the R-matrix calculation (calc.) and the Legendre fit to the experimental data (exp.).

Summary liq.scint.meas. Na

- *R-matrix describes total and inelastic*
- *Parameters available (report, CEA)*
- *Elastic data not well described*
- *Expt. elastic+inelastic does not equal total of Larson and Cierjacks*
- *May be due to response modeling of detectors and the very low thresholds for some energies and angles*

nELBE experiment

D(n,n)D

nELBE neutron source $\gamma+Pb, Pb(\gamma,xn)$

6.2 m flight path

AECL CD2 target

IRMM 6Li -glass setup

15° 4 detectors

165° 4 detectors

0.3 m target-detector distance

Focus on the problem area

$E_n = 0.1-1.0$ MeV

Li-glass setup

*Eight Li-glass detectors
95% enriched in ^6Li
51 mm \varnothing x 12.7 mm thick
Scionix, Netherlands*

*15° Four detectors
165° Four detectors
2 Assemblies swapped half way
Ratio 15/165 by detector*

*CD2 (AECL)
C (Goodfellow)
Blank (Air)
Natural background*



AECL's supplied CD_2 sample 

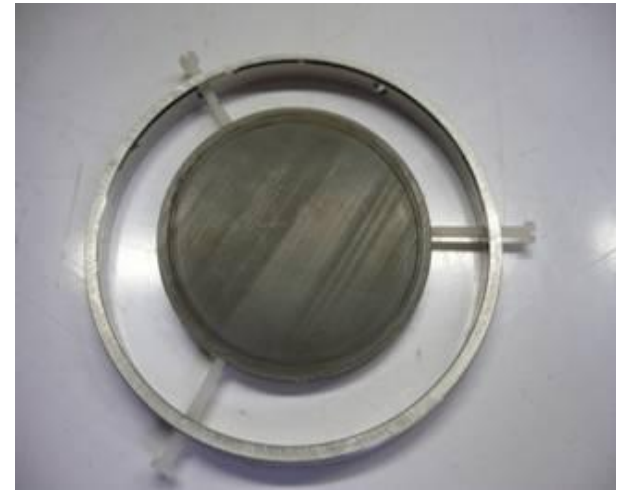

Setup at nELBE

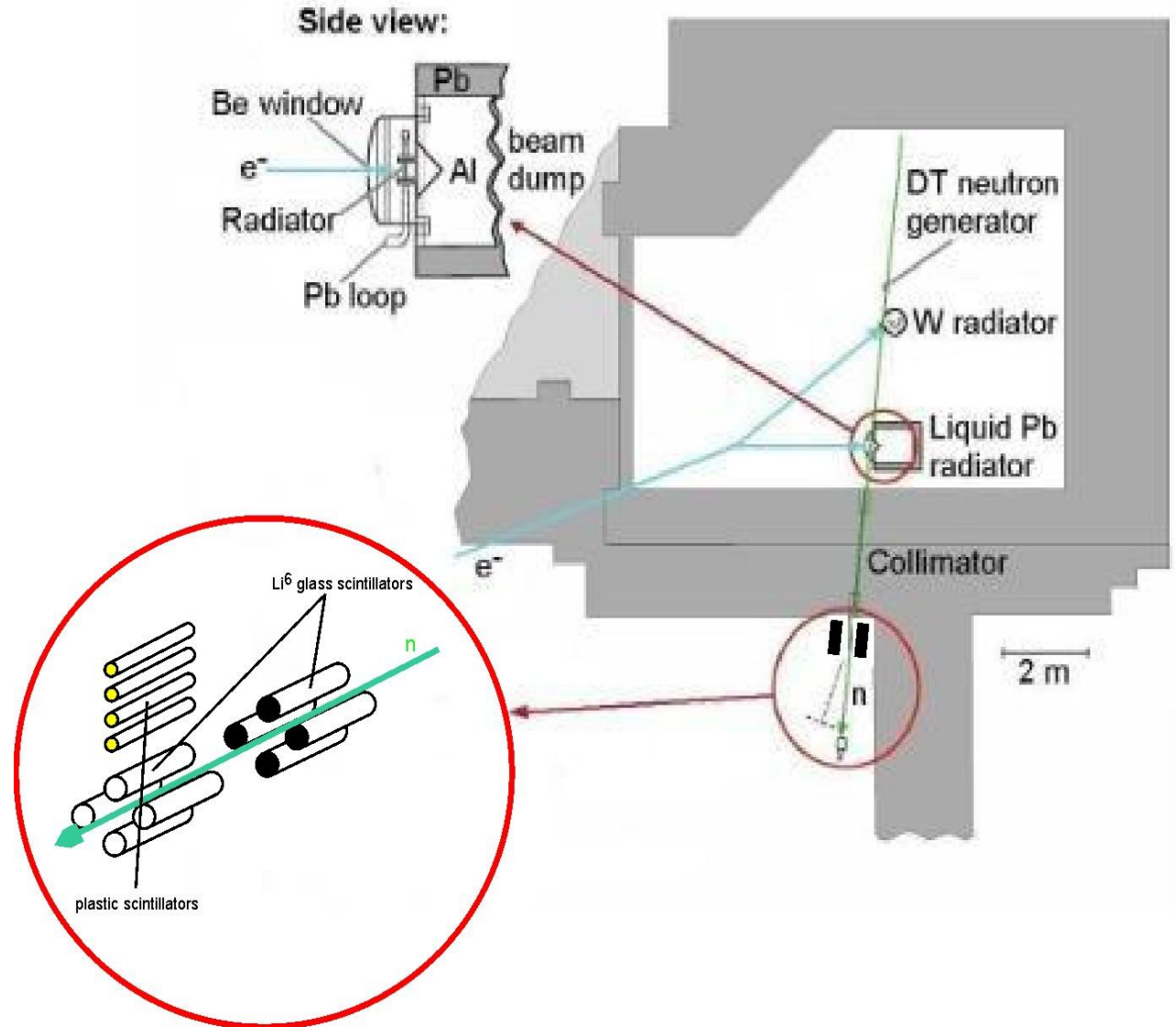
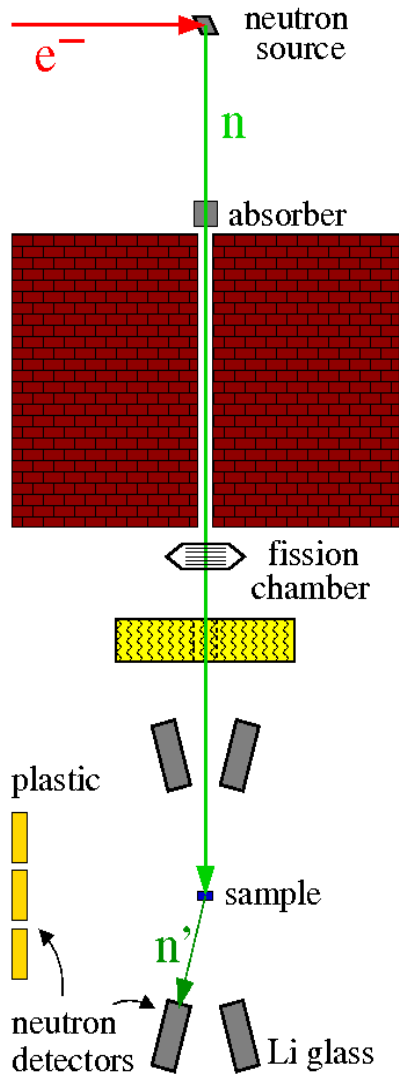

MCNP model scintillators and sample

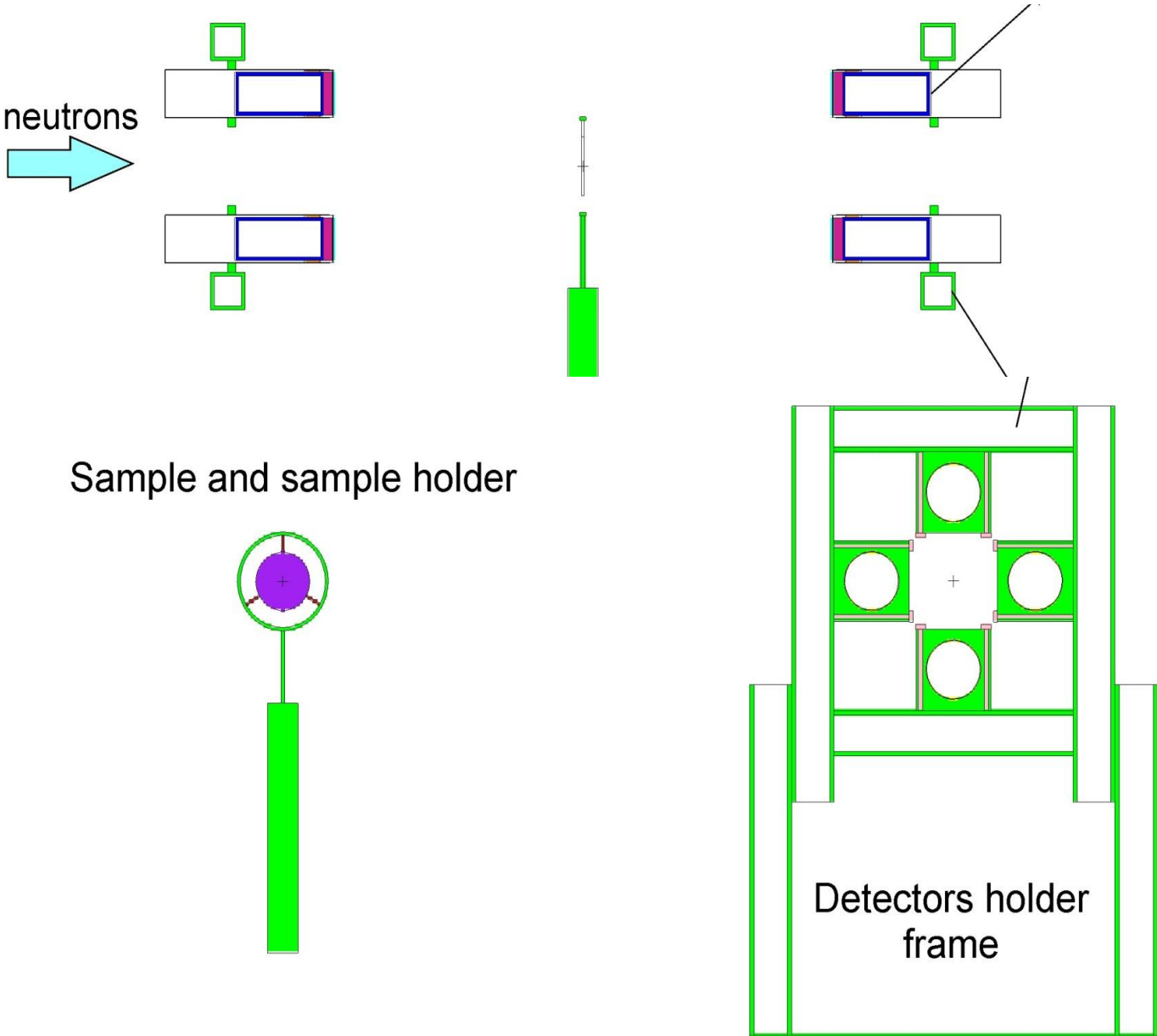

Time-of-flight, pulse height

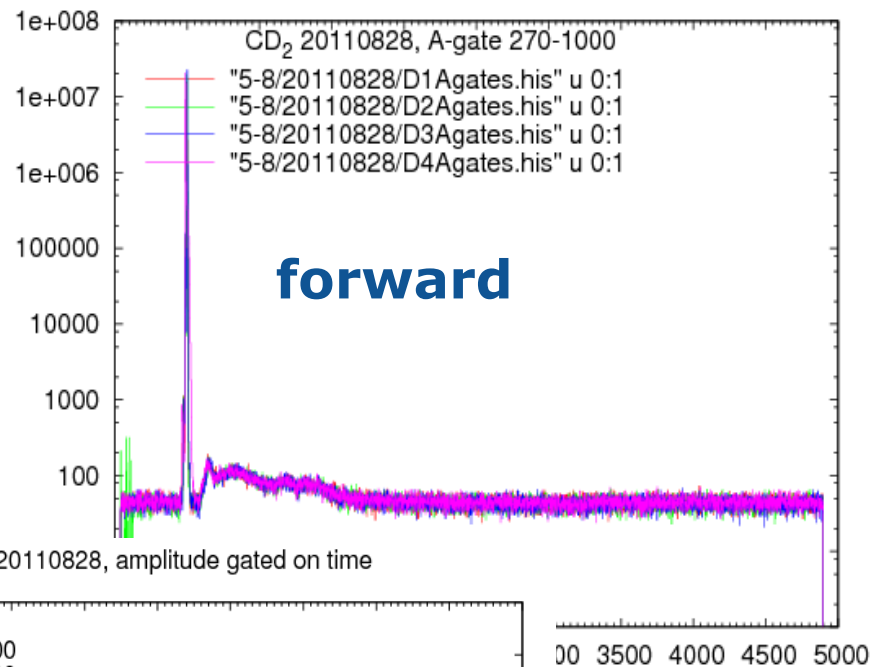
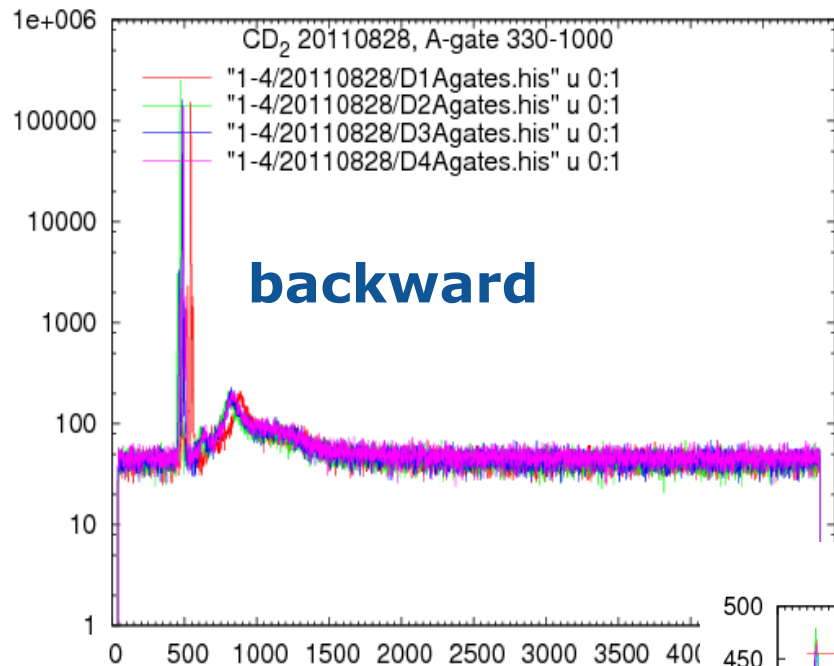

CD₂ 20110828, amplitude gated on time

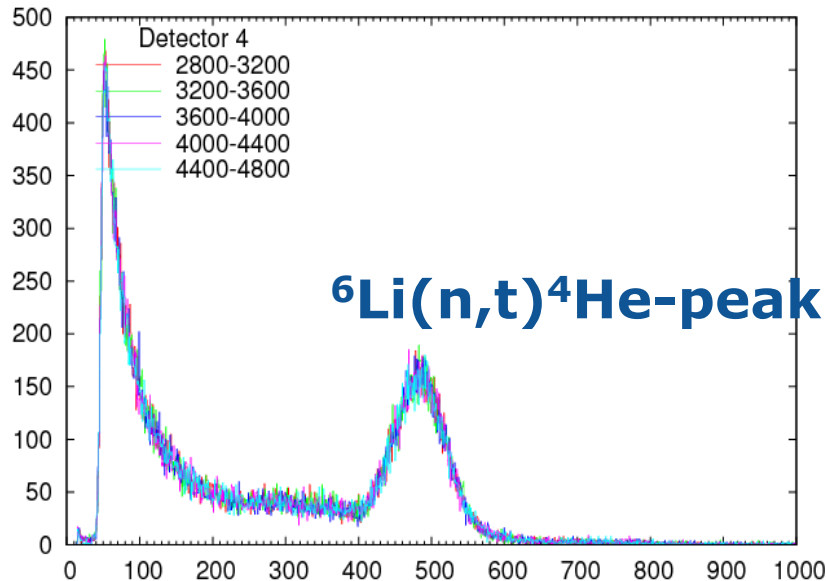

**Pulse height spectrum
Long times**

**Room return
neutrons**

Pulse heights with gate on time

CD₂ 20110828, amplitude gated on time

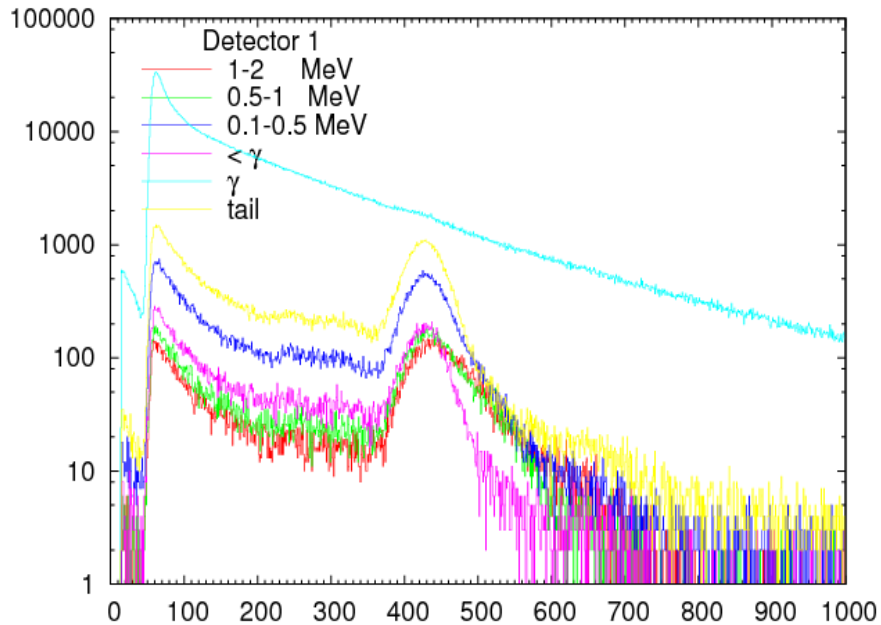

CD₂ 20110828, amplitude gated on time

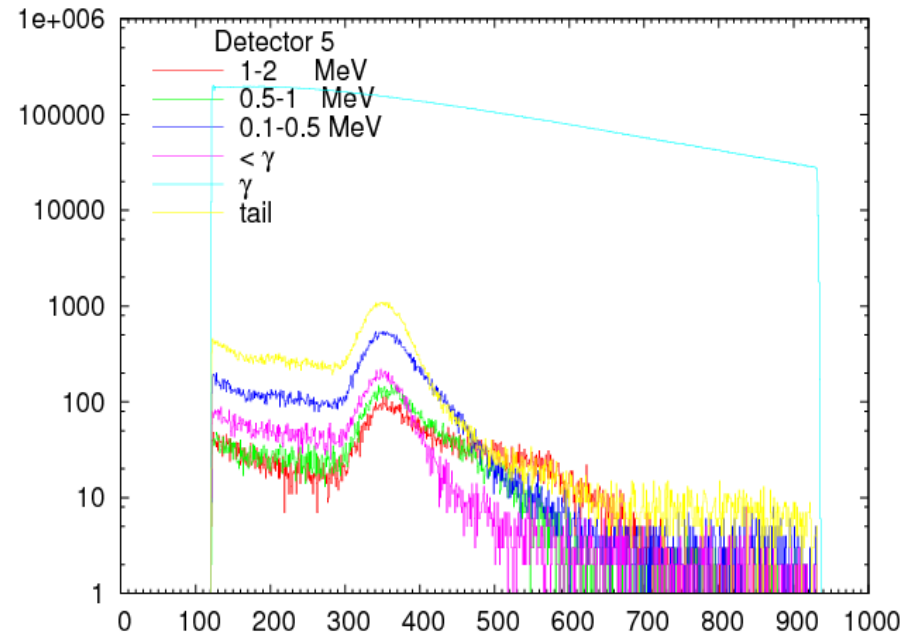

Pulse heights, room return subtracted

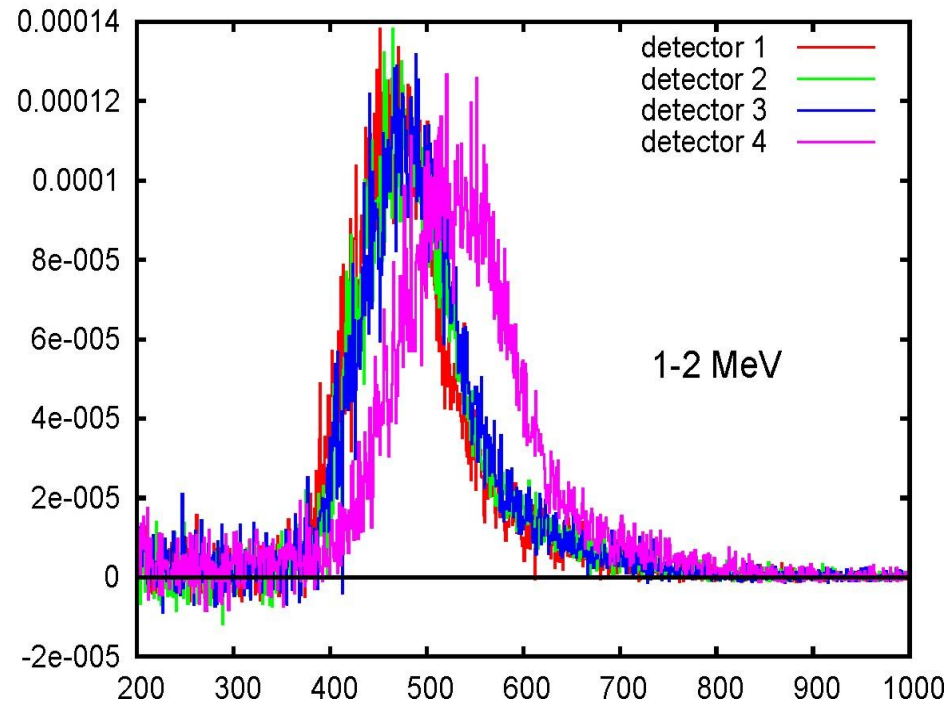
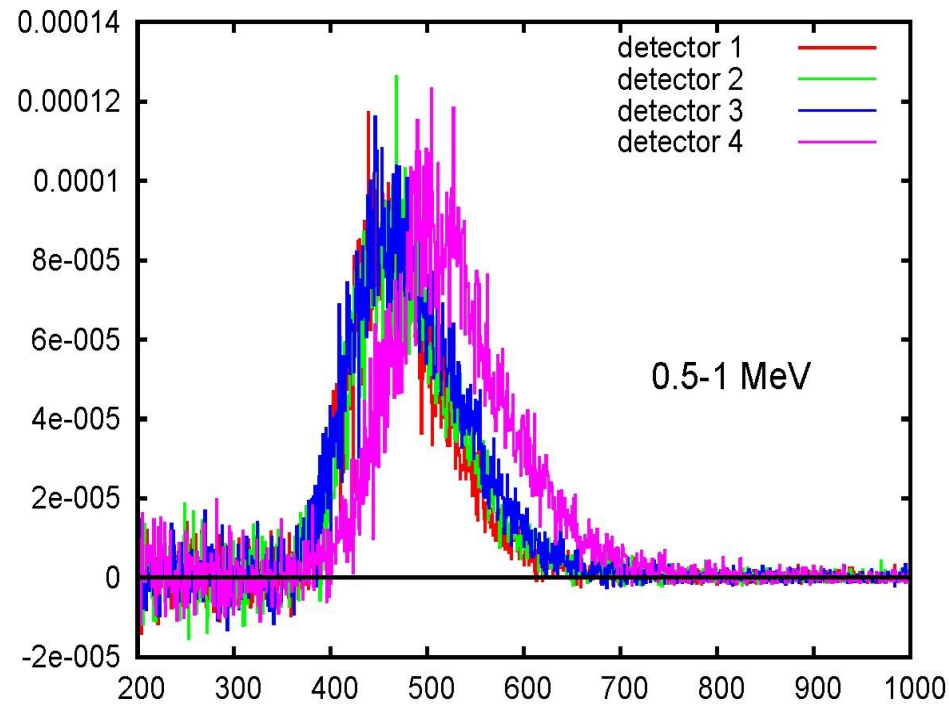

CD₂ sample
Rough time windows
Normalised to the number of fissions
Integrals needed over finer time windows

Net peak areas, no room return

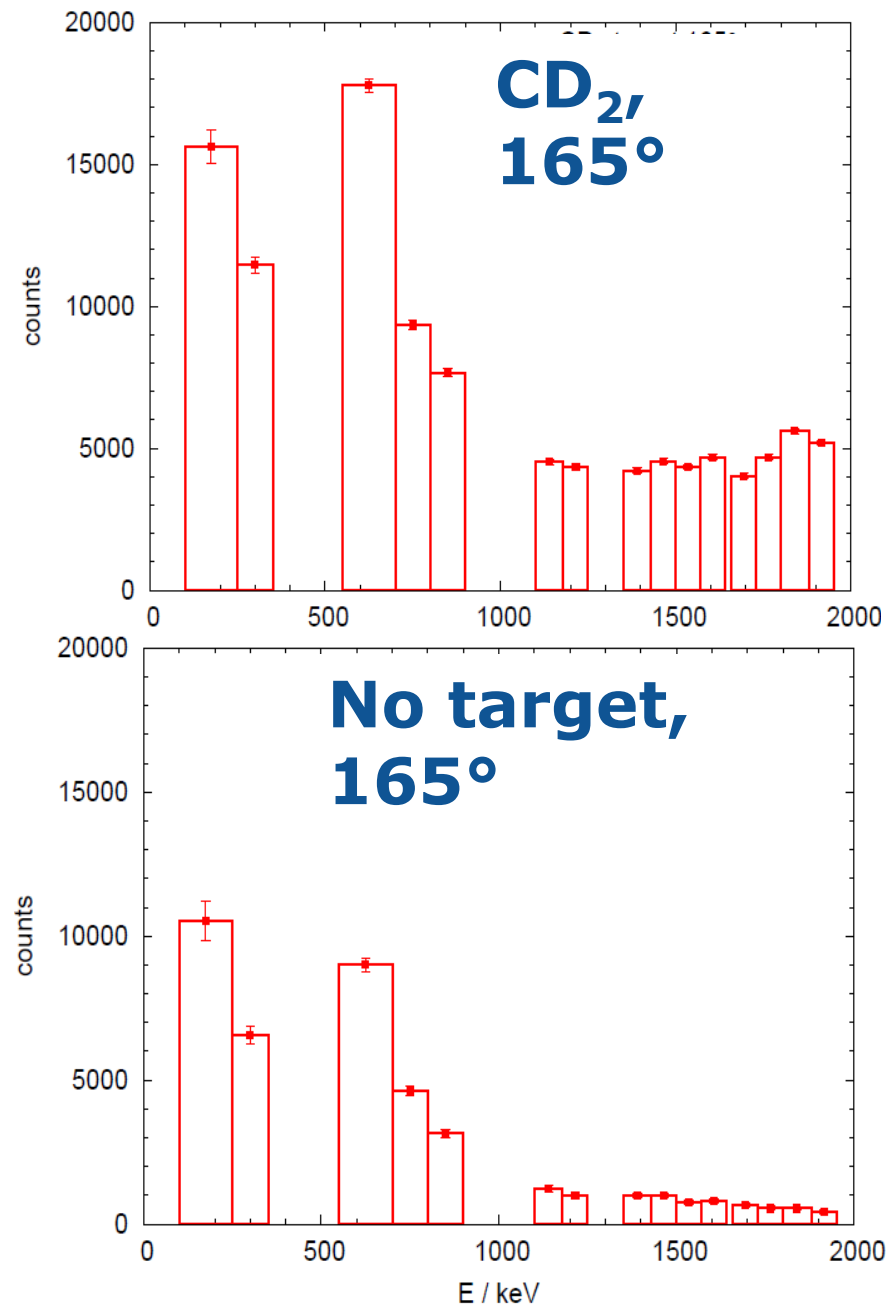
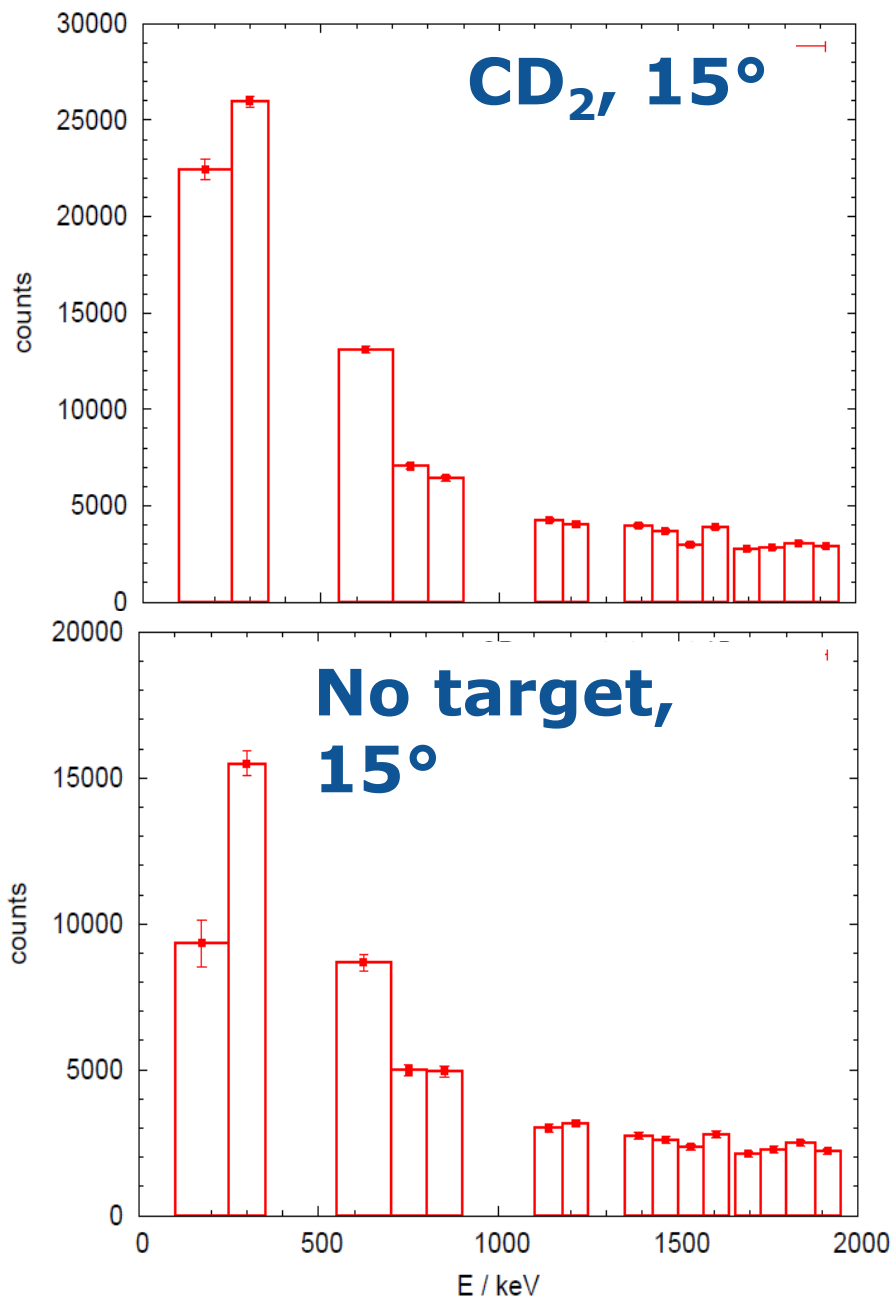

Multiple scattering 165 degrees

Normalized MCNP counts at lower sample densities (165°)

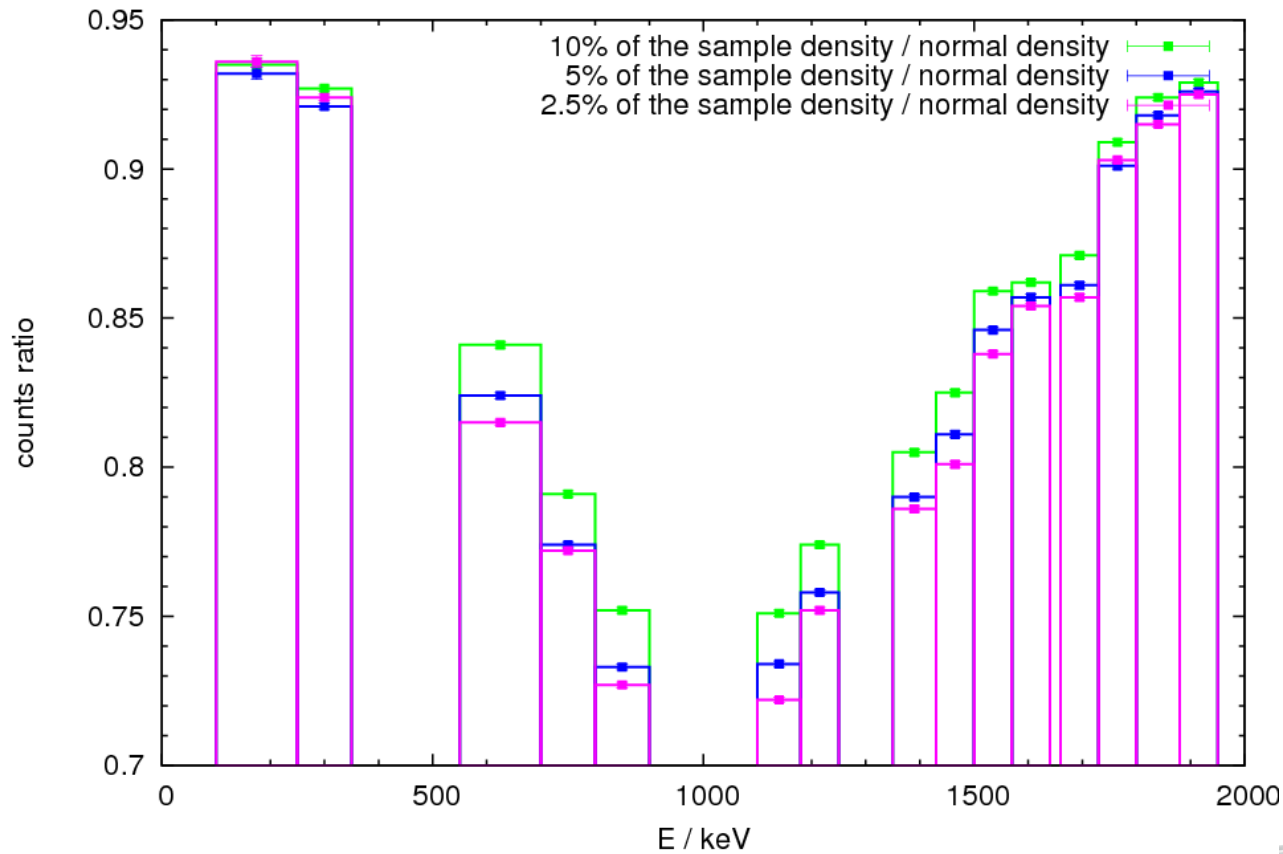

Multiple scattering 15 degrees

Normalized counts at lower densities (15°)

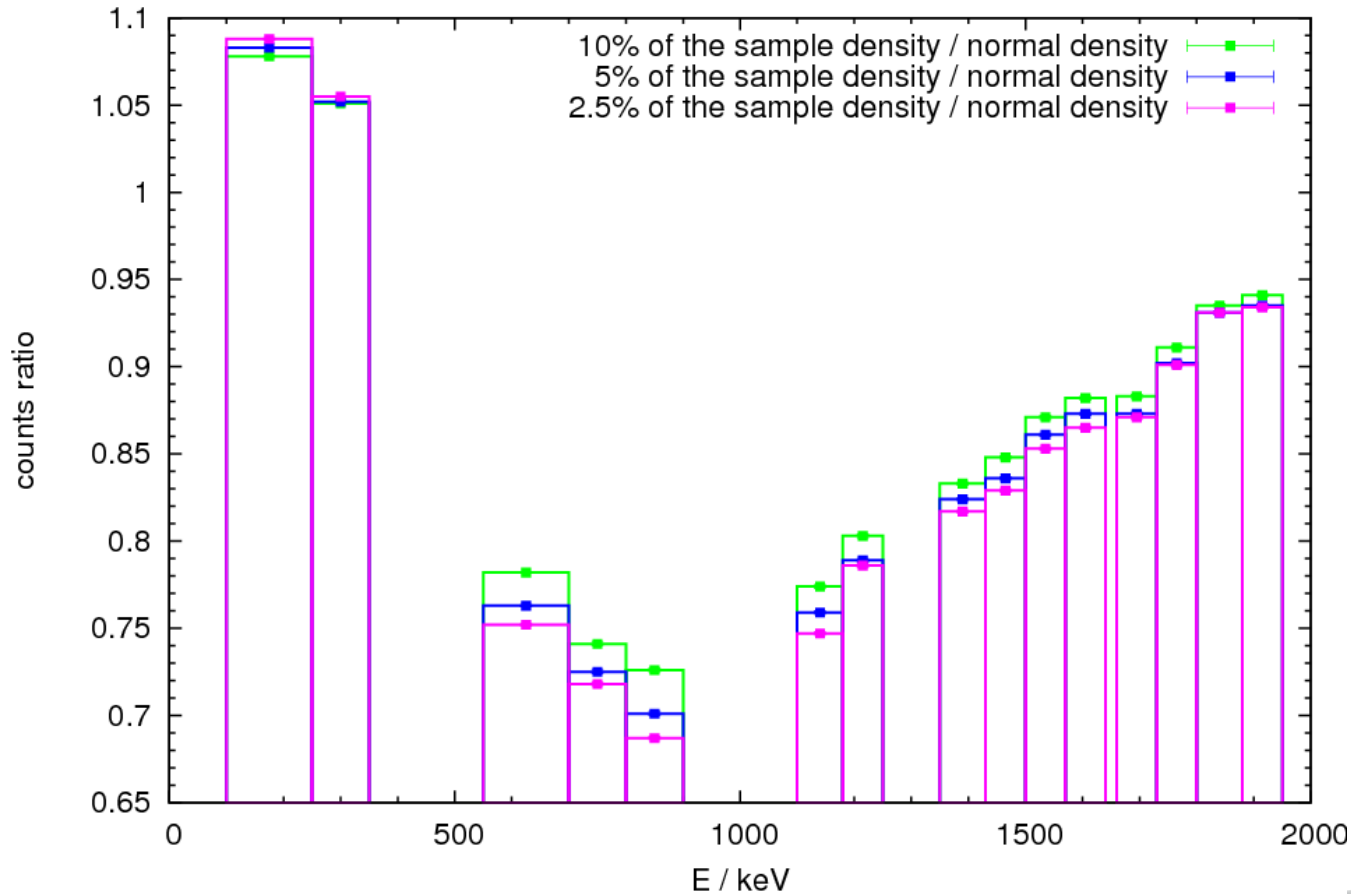

Carbon contribution 165 degrees

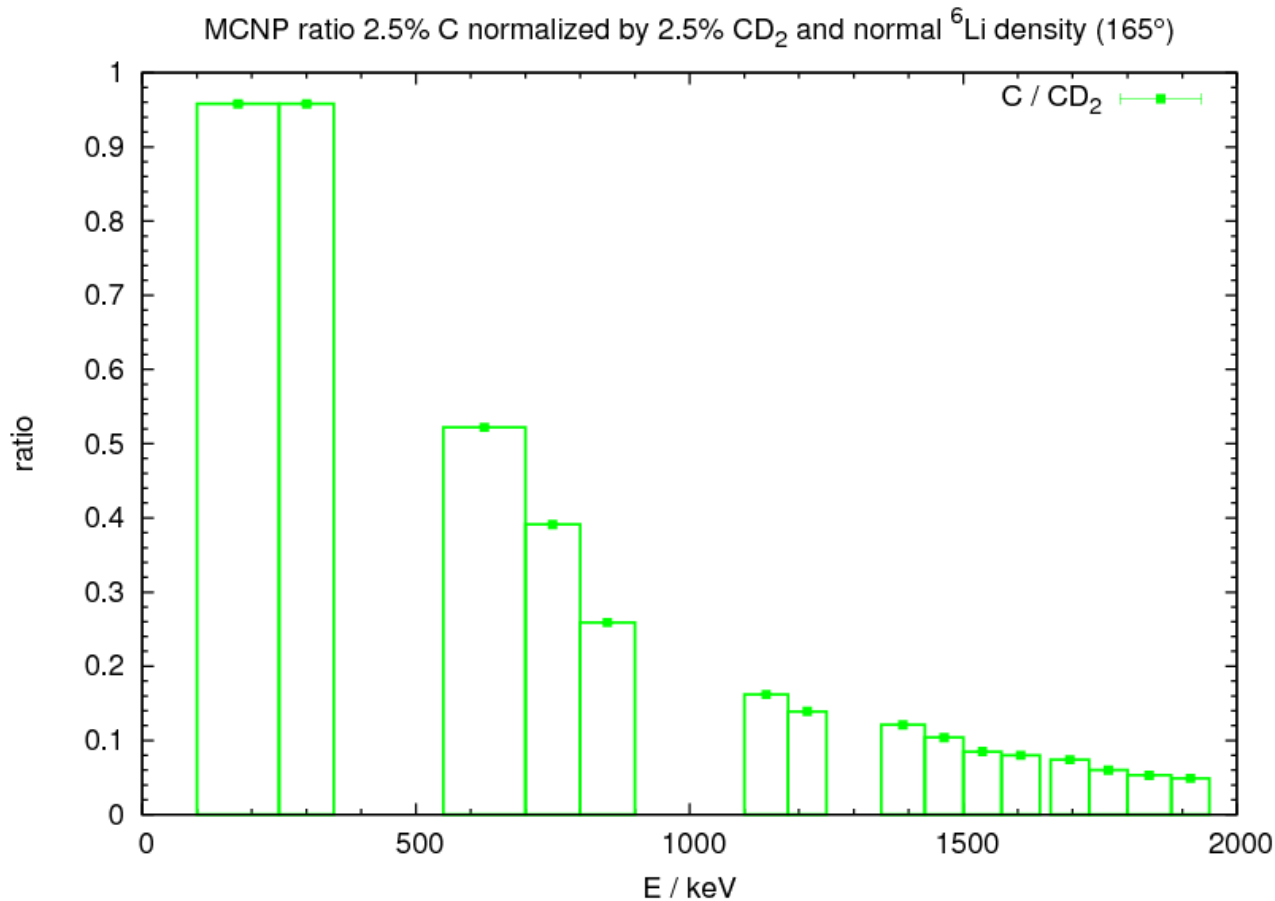

Carbon contribution 15 degrees

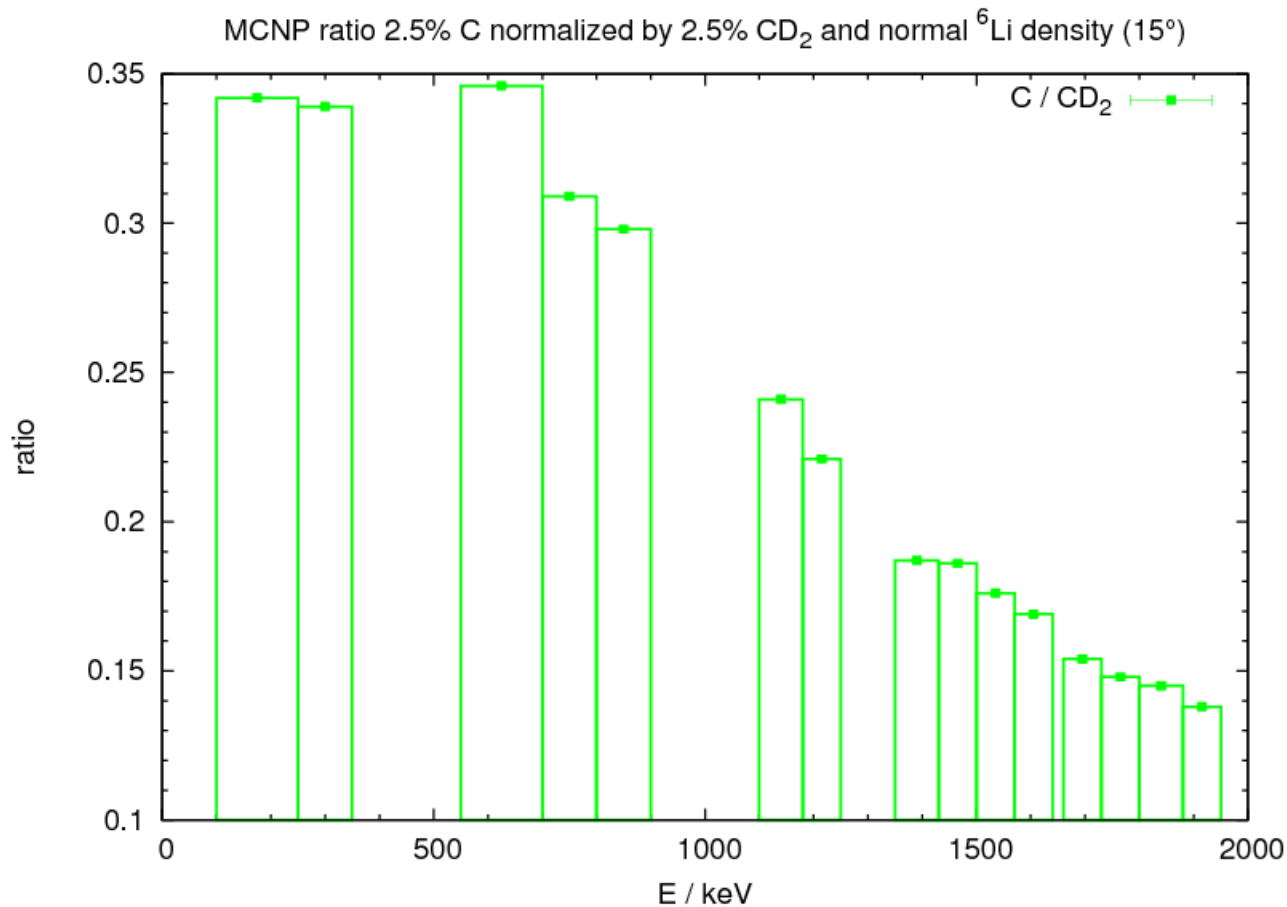

Summary $D(n,n)D$

- *GELINA measurements too slow (no suitable FP: later in 2013, 30m will be available)*
- *nELBE 6m FP looks promising*
 - **Room return important**
 - **Air in path beam important**
 - **Multiple scattering and carbon contribution by calculation with MCNP**
 - **Normalization is still an issue (no final result)**
 - **Detector efficiency check (to do shortly)**