

The European Commission's science and knowledge service

Joint Research Centre

Summary of experiments

Europe

Arjan Plompen



Contents (Geel, linac)

- Validation of resonance parameters from measurements on CBNM standards (collaboration with JAEA)
- Validation of nuclear data by combining transmission data at GELINA and pile oscillator measurements with pellet samples at MINERVE (collaboration with CEA Cadarache)
- Improve resonance data for Ag (collaboration with CEA Cadarache)
- Improve resonance data for criticality safety (collaboration with ORNL)

NRTA: Transmission station for validation of resonance data

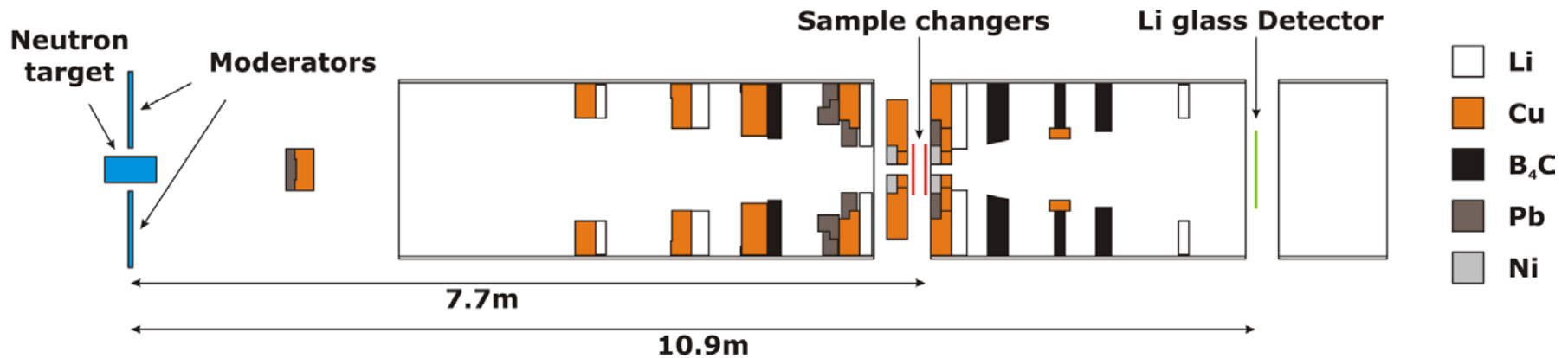

NRTA: CBNM U standards at GELINA

U_3O_8 reference sample
EC NRM 171

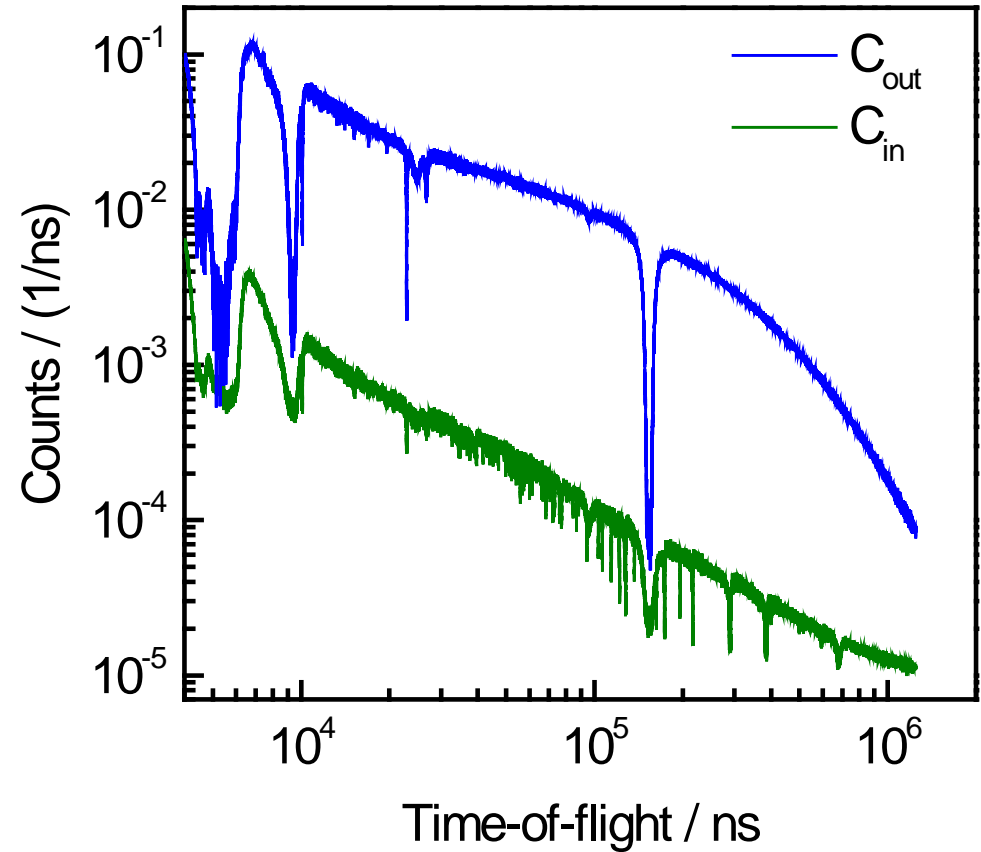
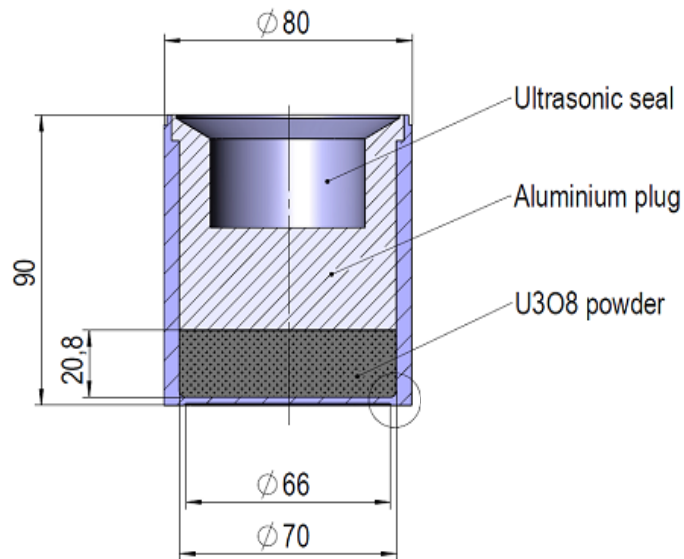

NRTA: CBNM U standards at GELINA

U_3O_8 reference sample
EC NRM 171

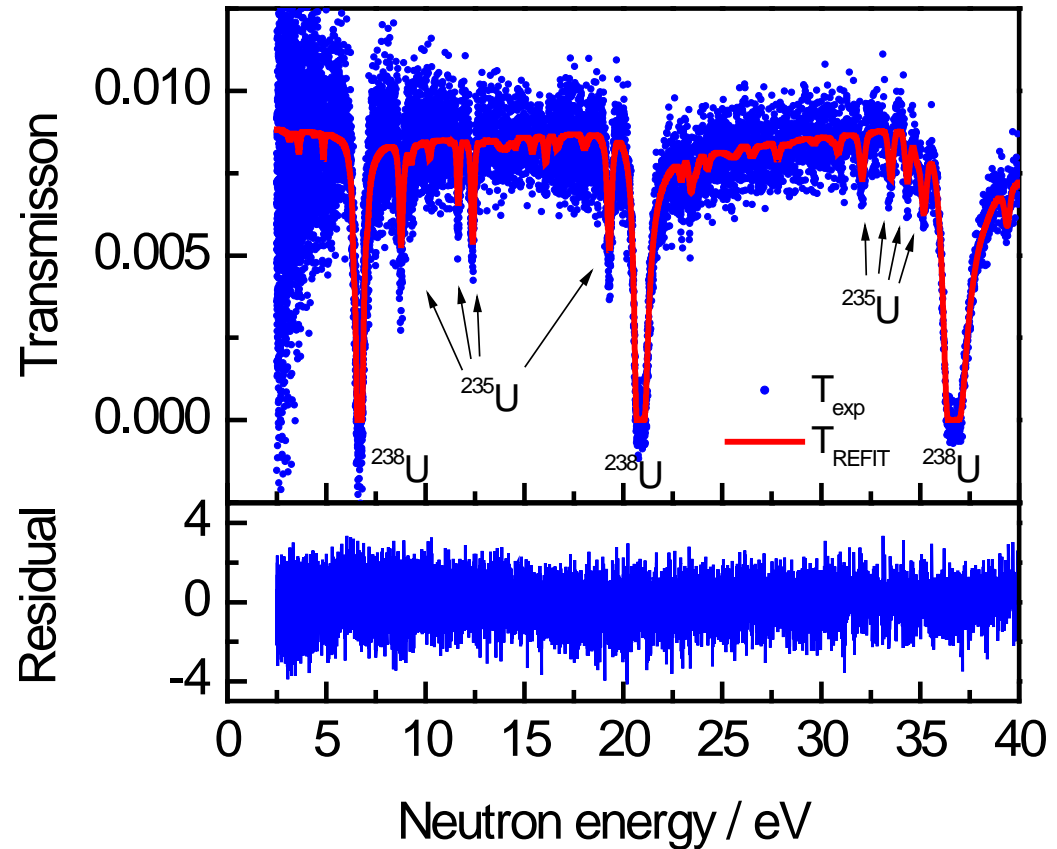
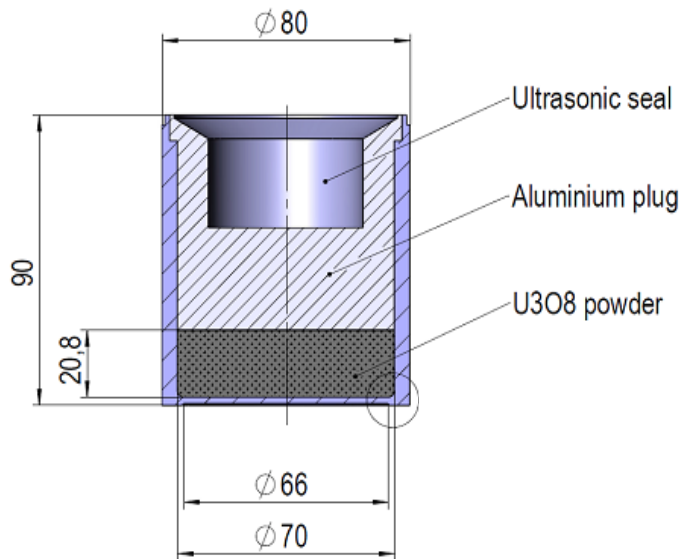

NRTA: CBNM U standards at GELINA

U₃O₈ reference sample
EC NRM 171

U-isotope	Areal number density (at/b)		Ratio
	Declaration	NRTA	
²³⁵ U	$(5.0326 \pm 0.0080) \times 10^{-4}$	$(5.063 \pm 0.09) \times 10^{-4}$	1.006
²³⁸ U	$(1.0628 \pm 0.0015) \times 10^{-2}$	$(1.062 \pm 0.01) \times 10^{-2}$	0.999

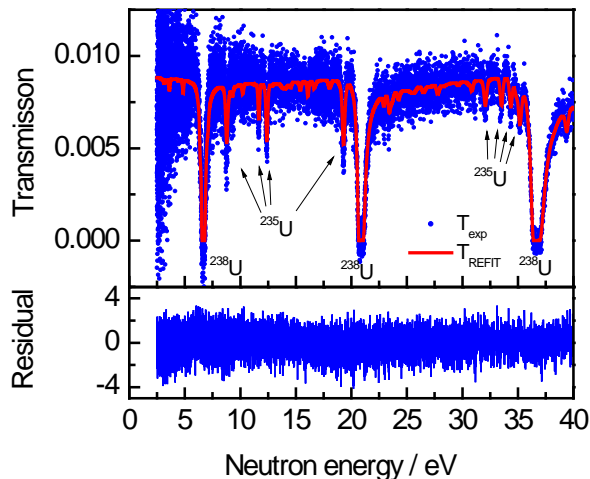

⇒ bias < 1.0
%

NRTA: CBNM Pu standards at GELINA

Plutonium Isotopic Abundance on
June 20, 1986

Atom Percent

Material	^{238}Pu	^{239}Pu	^{240}Pu	^{241}Pu	^{242}Pu	$^{241}\text{Am}/\text{Pu}$
CBNM Pu 93	0.0117	93.4392	6.2886	0.2215	0.0390	0.1039
CBNM Pu 84	0.0706	84.3985	14.1578	1.0197	0.3534	0.2157
CBNM Pu 70	0.8506	73.4248	18.2445	5.4257	2.0544	1.1624
CBNM Pu 61	1.2045	62.6562	25.3526	6.6376	4.1491	1.4362

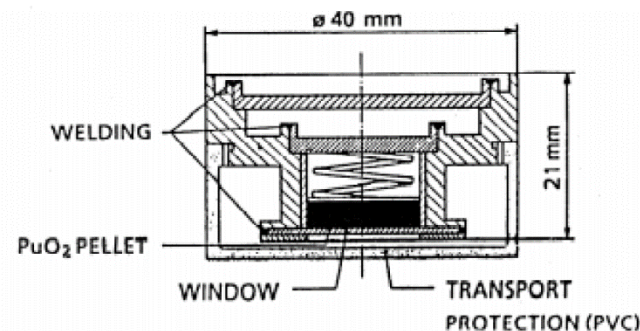

NRTA: CBNM Pu standards at GELINA

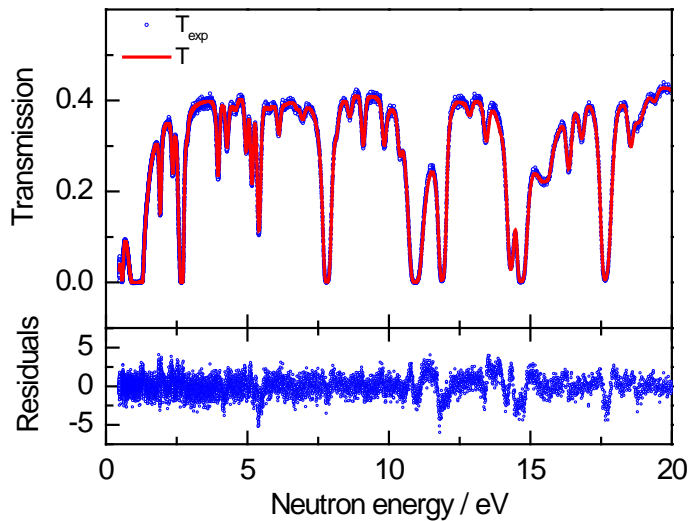

Note: ^{241}Am parameters from latest JEFF 3.2 evaluation

Nuclide	n_{NRTA}	n_{REF}	$n_{\text{NRTA}}/n_{\text{REF}}$
^{238}Pu	0.0098 ± 0.0002	0.00950 ± 0.00002	1.031 ± 0.020
^{239}Pu	0.6250 ± 0.0010	0.62602 ± 0.00028	0.999 ± 0.002
^{240}Pu	0.2630 ± 0.0002	0.25272 ± 0.00024	1.039 ± 0.001
^{241}Pu	0.0157 ± 0.0001	0.01549 ± 0.00002	1.016 ± 0.005
^{242}Pu	0.0398 ± 0.0001	0.04149 ± 0.00006	0.960 ± 0.002
^{241}Am	0.0632 ± 0.0001	0.06300 ± 0.00063	1.003 ± 0.001

Comparison GELINA – MINERVE data

Goal: Define analytical expressions for homogeneous samples with a complex shape

Transmission experiments at FP 4 (50 m) with different Cu samples (bar and pellets)

- Cu-bar with $L = 10$ mm:
different orientation (30° , 45° , 90°) with respect to the direction of neutron beam
- Cu-bars with different dimensions at 90°
 - 20 mm x 10 mm
 - 20 mm x 5 mm
 - 10 mm x 5 mm
- Cu-cylindrical pellets with different diameter (data analysis in progress)
 - Diameter 5 mm
 - Diameter 10 mm

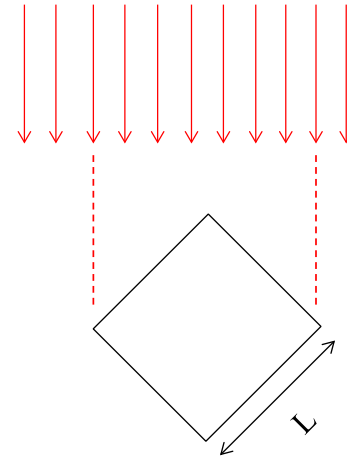

NRTA measurements on Cu-bar

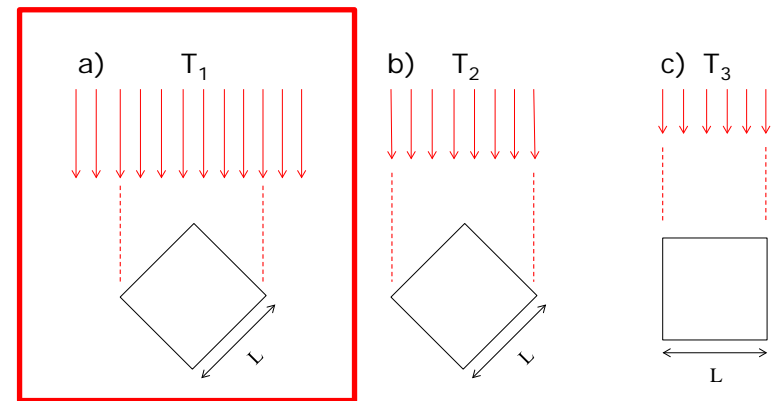
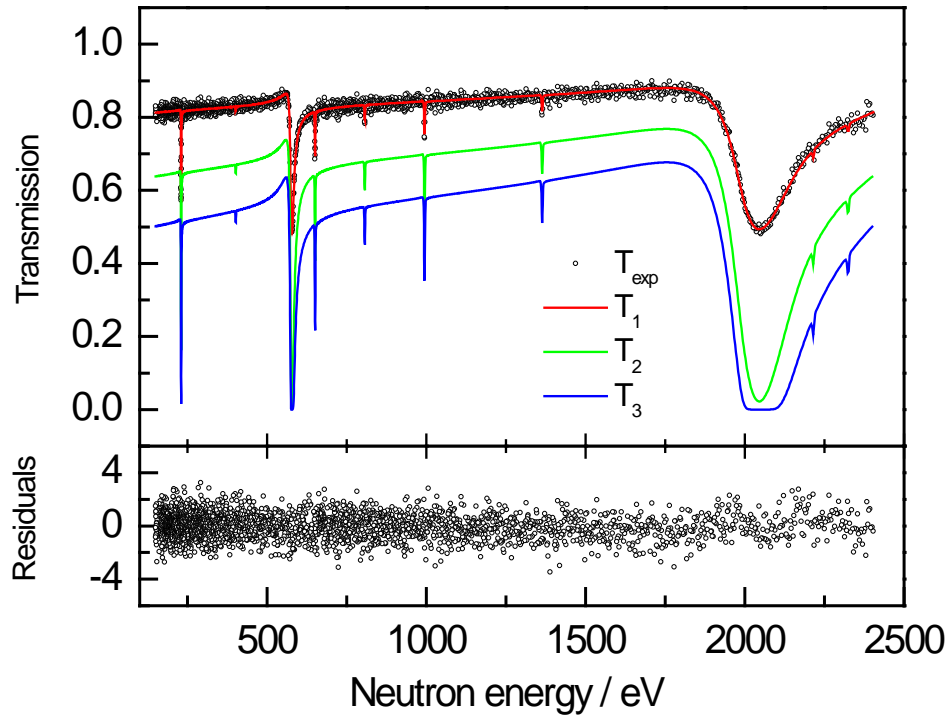

NRTA measurements on Cu-pellet

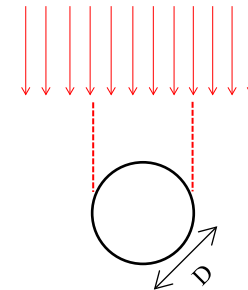
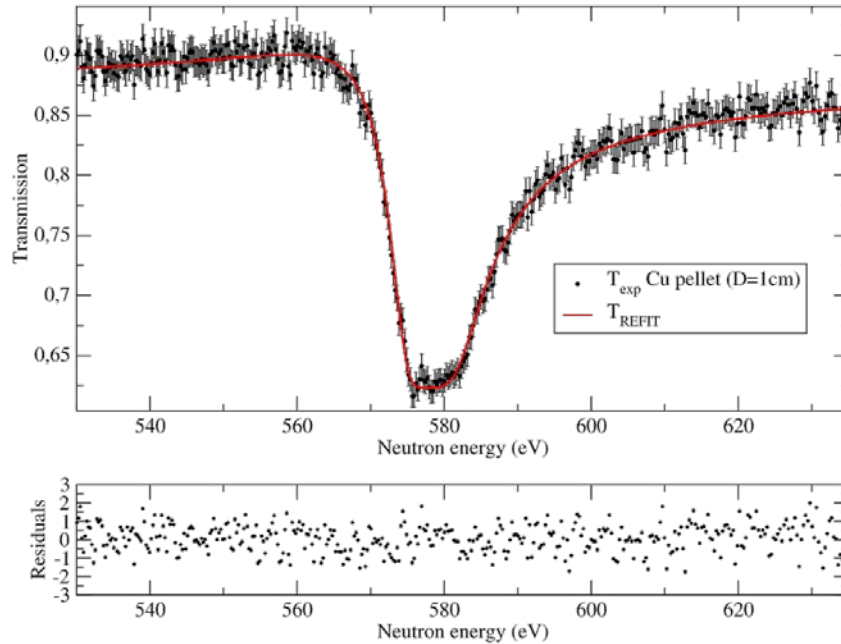

Validation of Ag resonance parameters

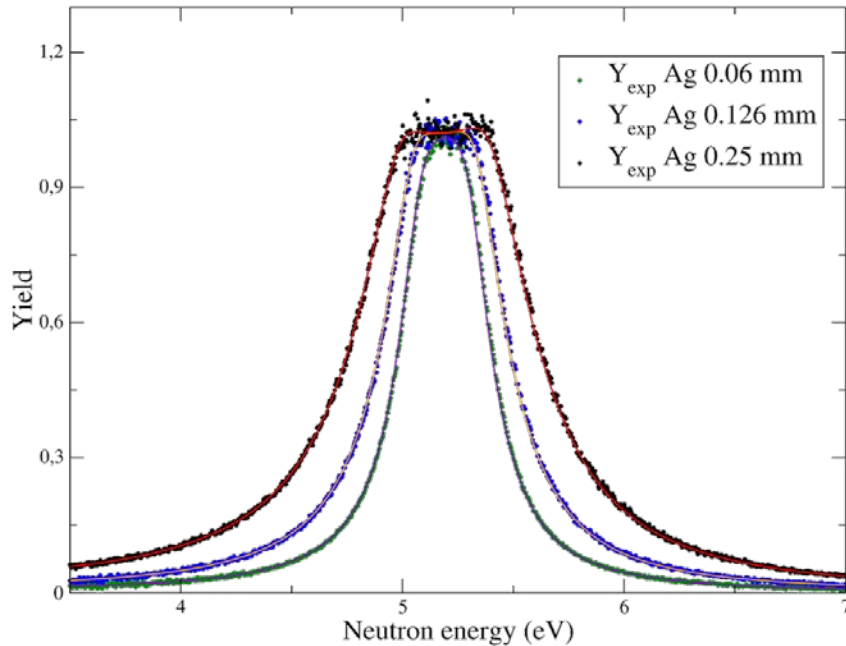

Normalisation from different samples (different thickness) fully consistent within 1%

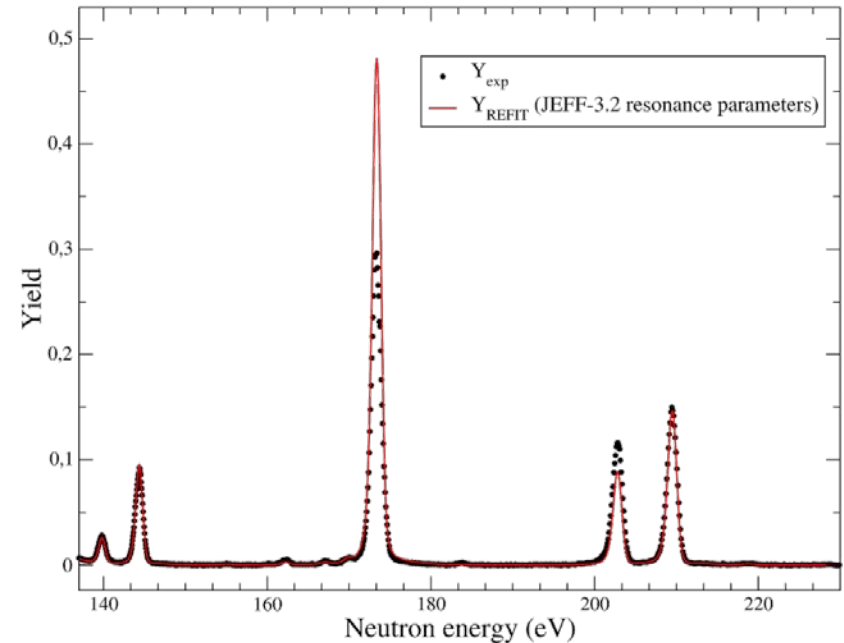

Resonance parameters can be improved

Nuclear data for criticality safety

- Criticality calculations require improved evaluations for structural materials, nuclear fuel and fission products
- A collaboration between ORNL and JRC has recently produced experimental data for Ca, Ce and V
- New capture and transmission measurements ongoing on ^{nat}Zr

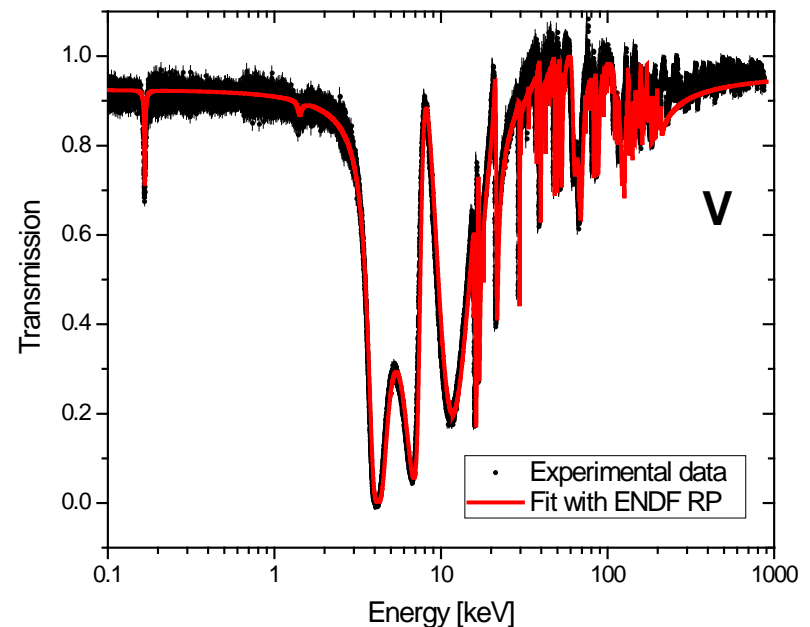
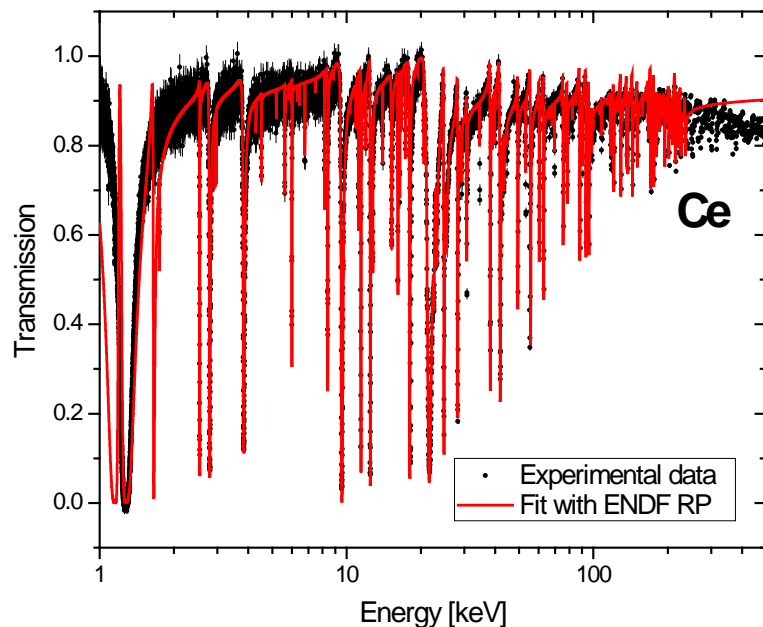

New experiments as key to high quality neutron multiplicities

Hambusch et al. JRC-Geel

- Motivation
- Experiment on prompt neutron emission of $^{235}\text{U}(n,f)$
 - SCINTIA array
 - 3D ionization chamber
 - Results
- VERDI (2E-2v) time-of-flight detector
- Conclusions

Motivation

PFN multiplicity correlations with fragment observables

Based on energy balance in fission

- Detailed modelling (CGMF, Fifielin, Freya...)
 - successfully reproducing correlations
 - in the case $^{235}\text{U}(n,f)$
 - » difficulties: in particular $\nu(\text{TKE})$

Lemaire et al. (2005)

"...a **dramatic deviation** between calculation and experiment on ν is observed **at low TKE** that would indicate the presence of **additional opened channels**"

Kornilov et al. (2007)

"The **incorporation of the SCN emission** leads to a much **better agreement** between theoretical and experimental data for $\nu(\text{TKE})$ in the high energy range. However, the assumption of **SCN emission at high TKE** should be confirmed with direct experimental data"

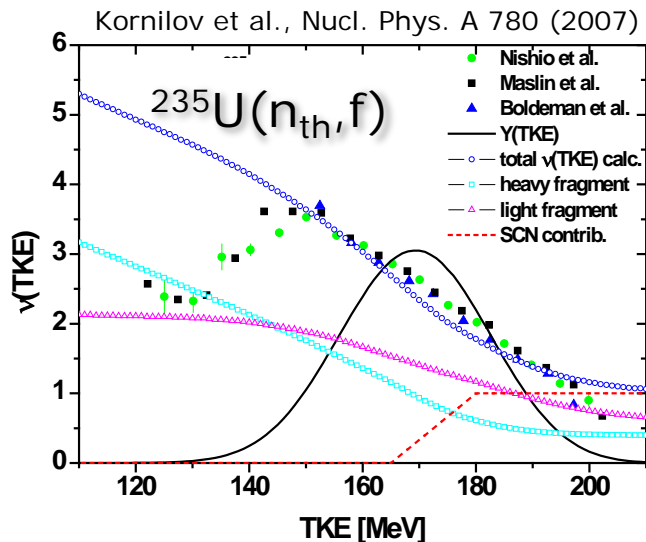
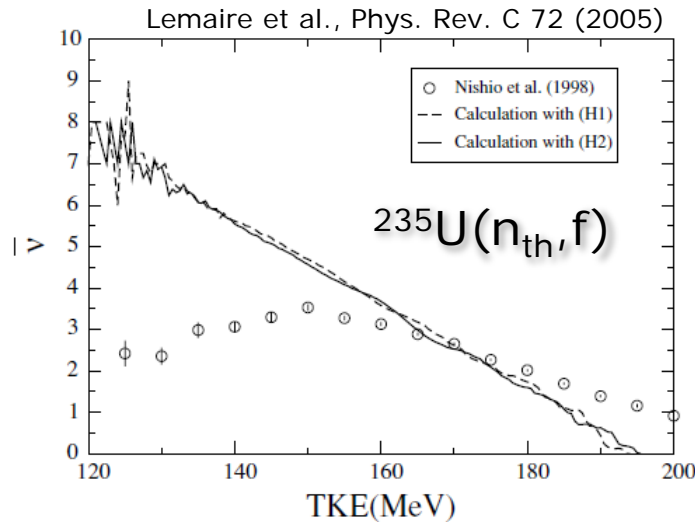

Experimental setup

GELINA neutron time-of-flight facility

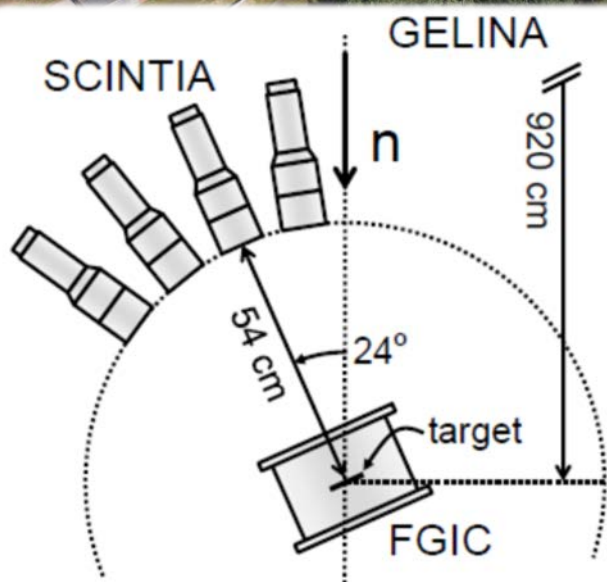
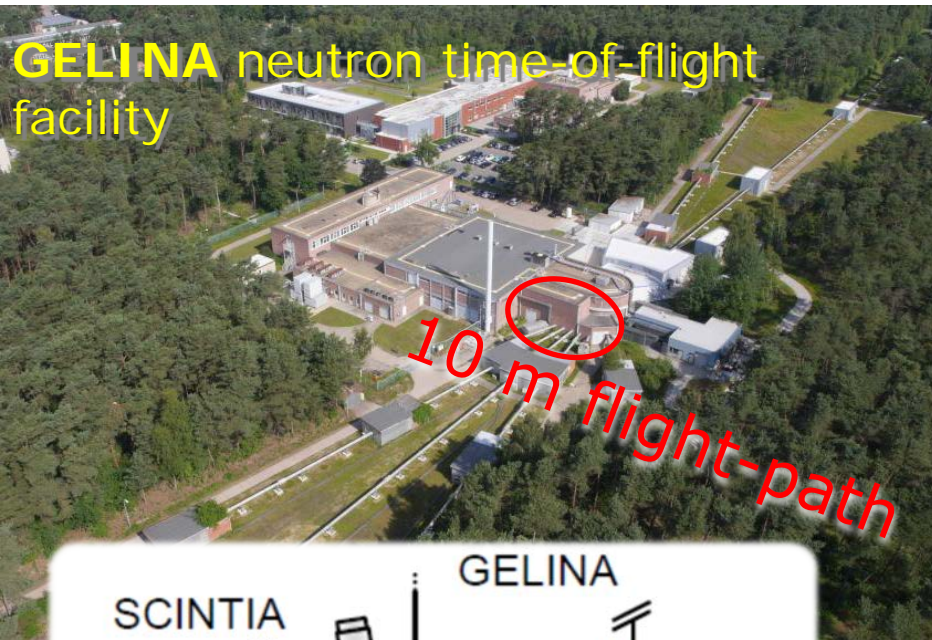

GELINA – neutron source

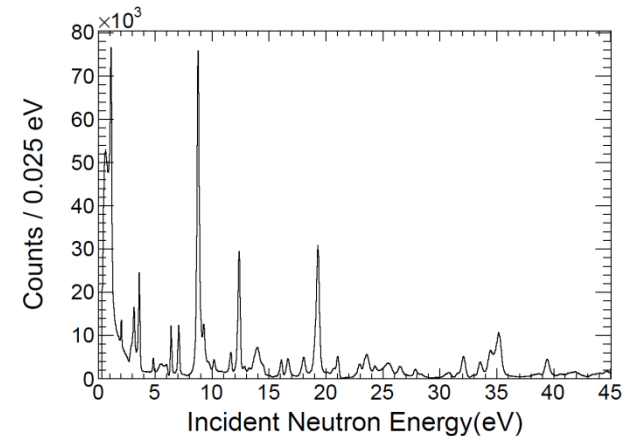

Twin Ionization Chamber

- Fission fragments
 - Energies
 - Masses - 2E-technique
 - Fission axis orientation

Neutron Detector Array SCINTIA

- 12 (22) x Scintillators
- Prompt fission neutrons
 - Energy (time-of-flight)

Validation of method $^{252}\text{Cf}(\text{sf})$

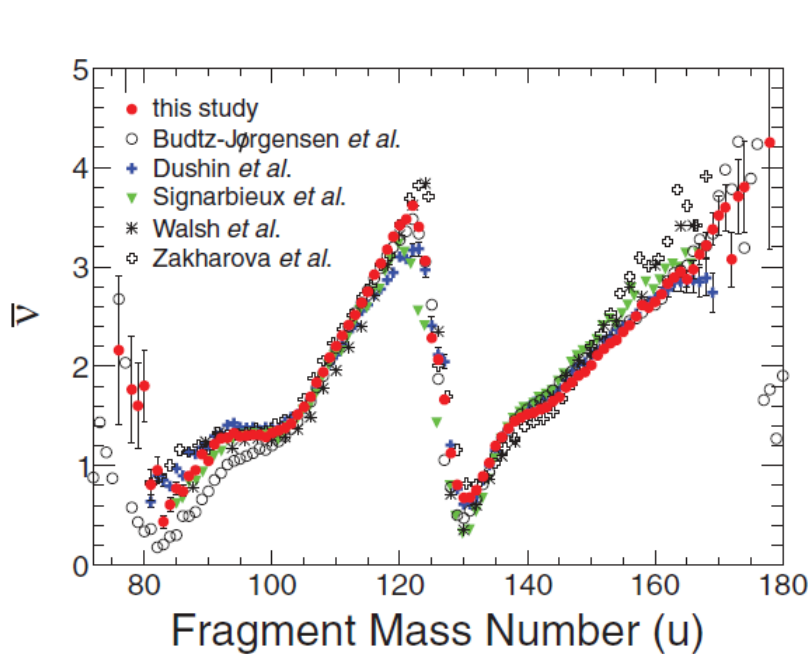

PHYSICAL REVIEW C **90**, 064611 (2014)

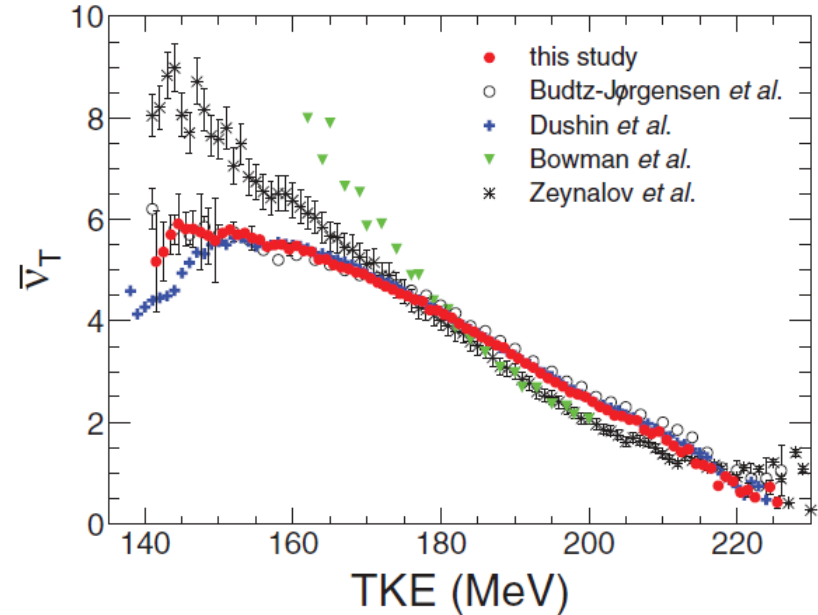

- Results show consistency with literature data
- Specifically with methods that do not suffer from neutron energy detection threshold
 - ✦ (Dushin *et al.*) Gd-loaded 4π scintillator tank

Position sensitive ionization chamber

Orientation of the fission axis in 3D-space is a requirement

Twin Ionization Chamber

- *Electron collector replaced by position sensitive electrode*
- *Charge-division readout*

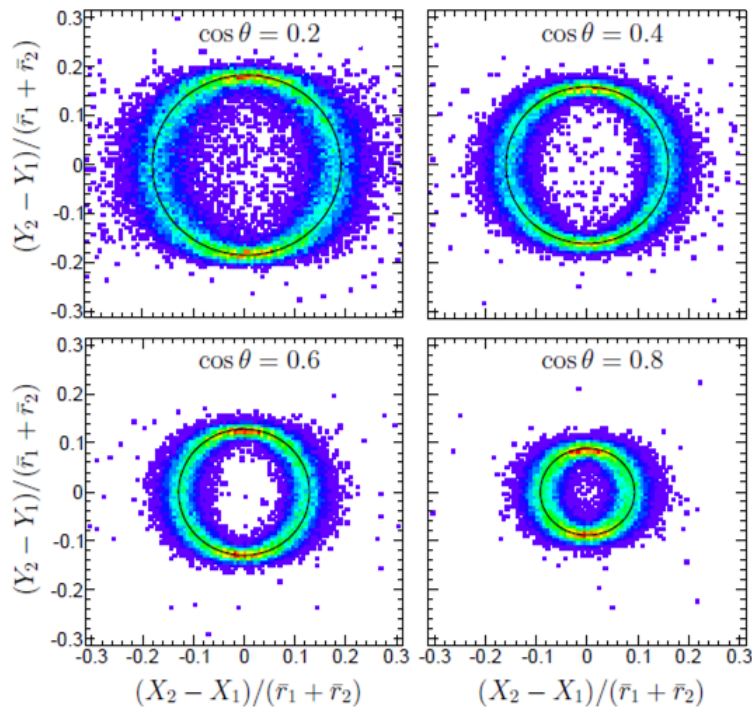
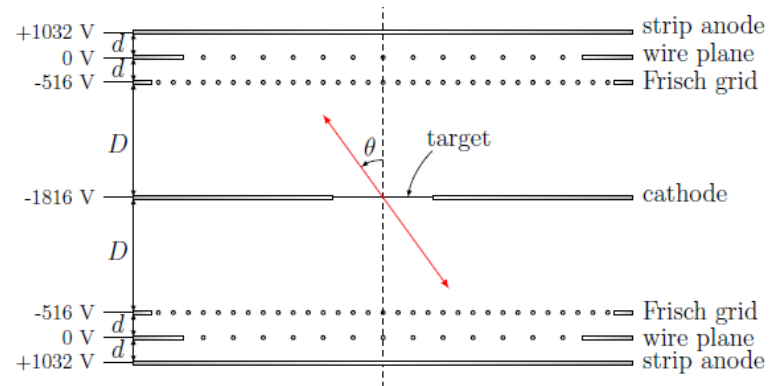

➤ Energy dependence of prompt neutron multiplicity

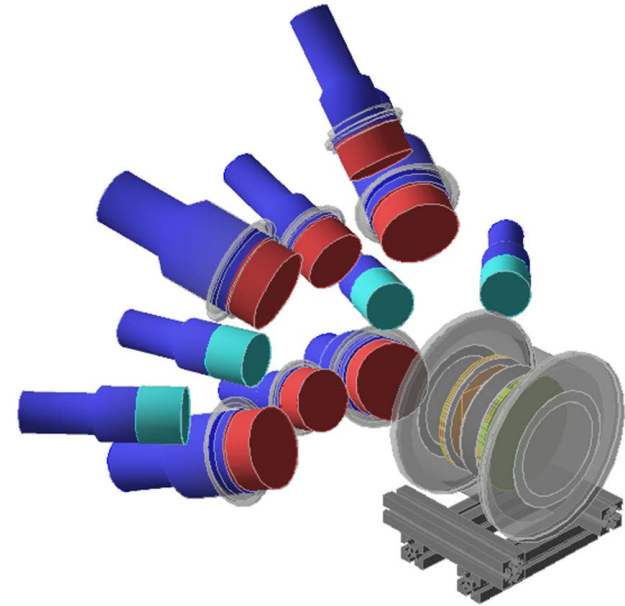
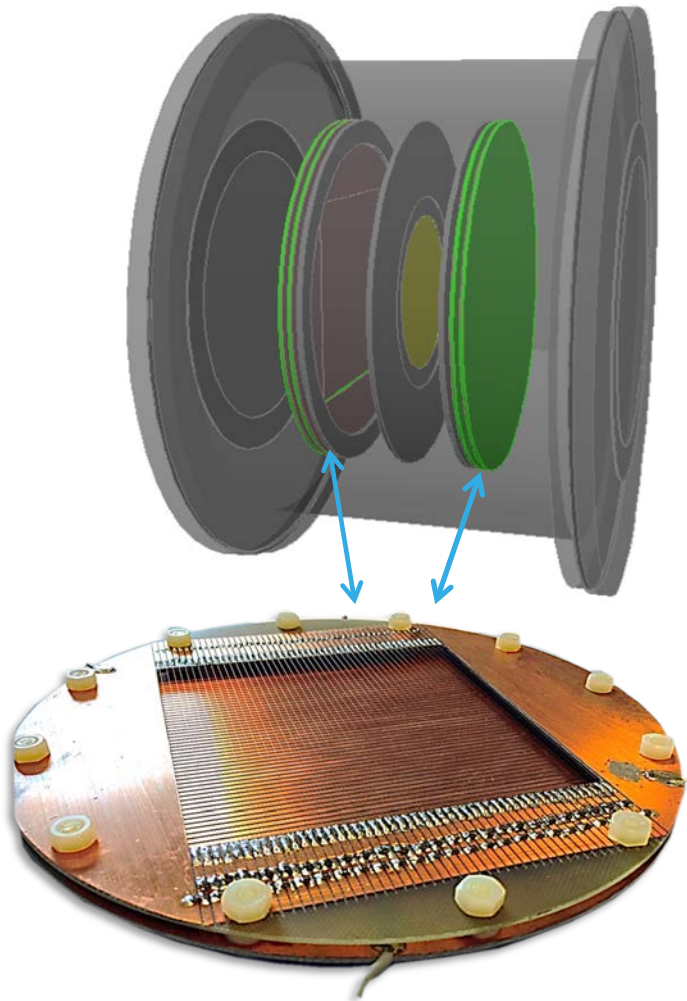

3D position sensitive ionization chamber

- ✓ JRC Geel in-house development
- ✓ state-of-the-art
- ✓ unique
- ✓ technical paper in Nucl. Inst. Meth. A 830

2E-analysis of FF data

Conservation of linear momentum

Correction for PFN emission

TKE dependence of neutron emission

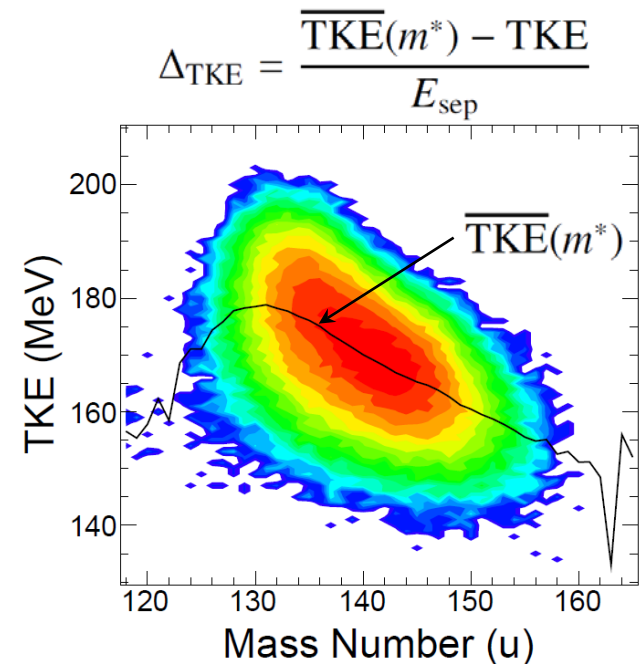
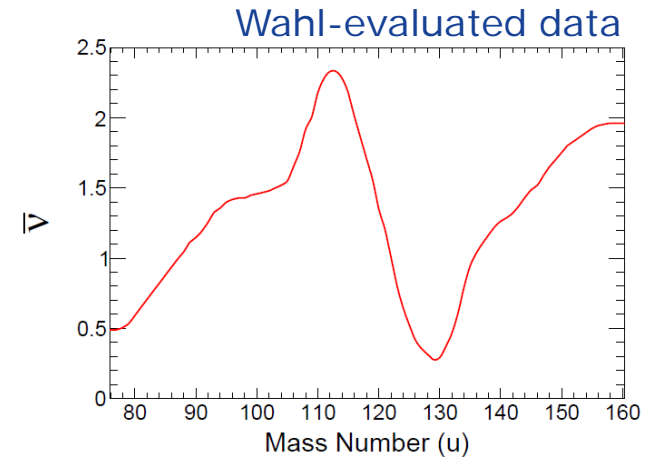
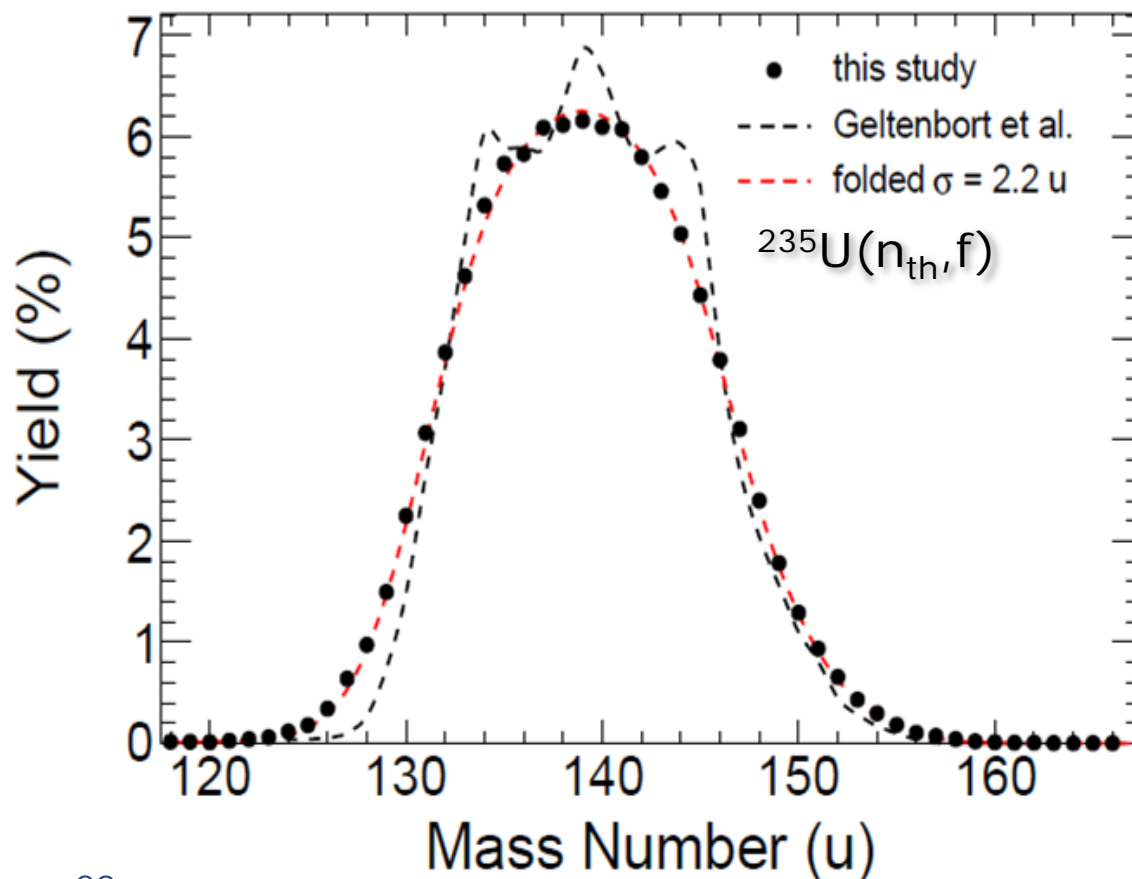

Multiplicity vs. Fragment Mass

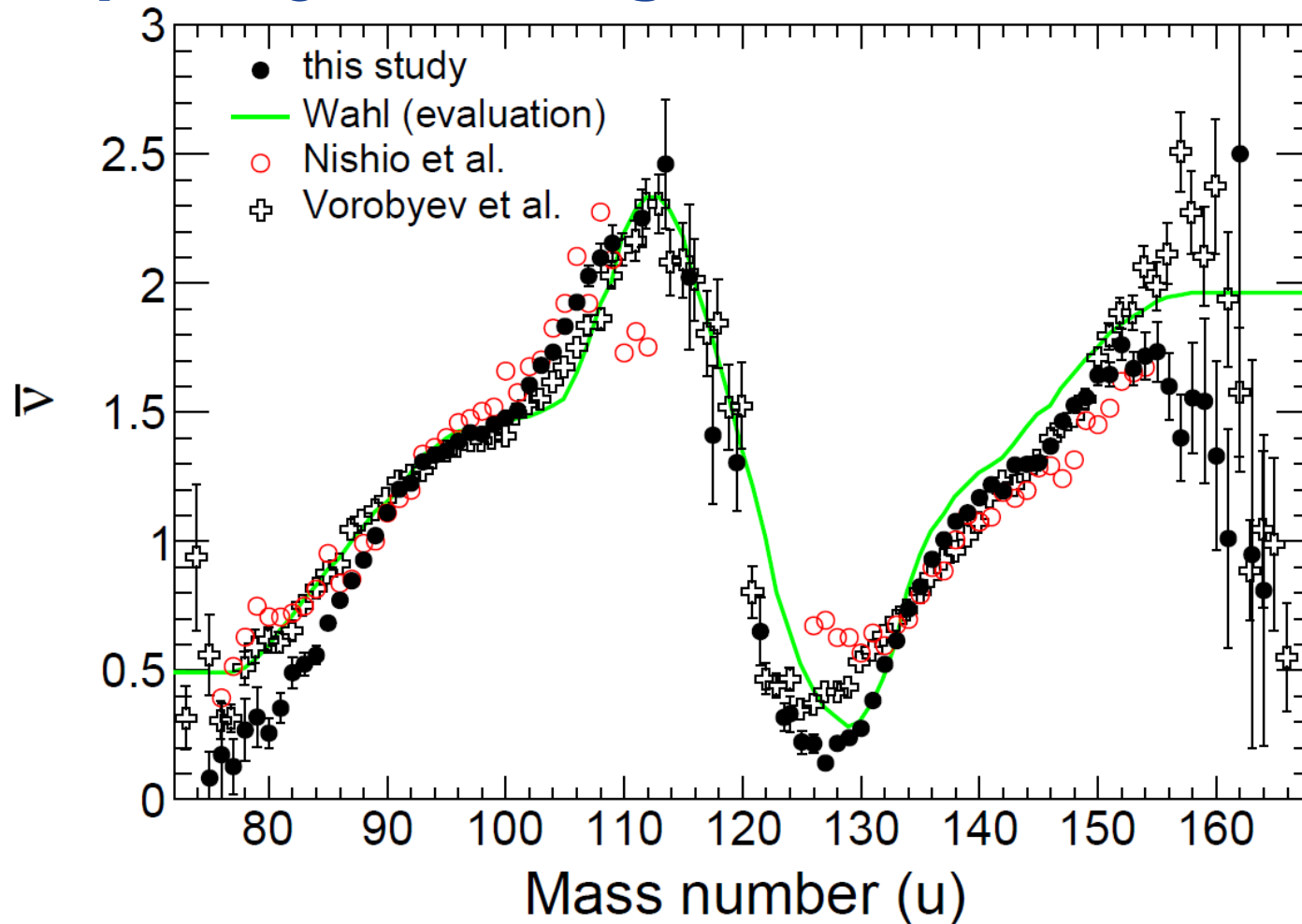

Shoulders around $A_L=100$ and $A_H=140$

Pronounced minima around $A_L=80$ and $A_H=130$

$E_n \in [0.3 \text{ eV}, 60 \text{ keV}]$

Multiplicity vs. Fragment TKE

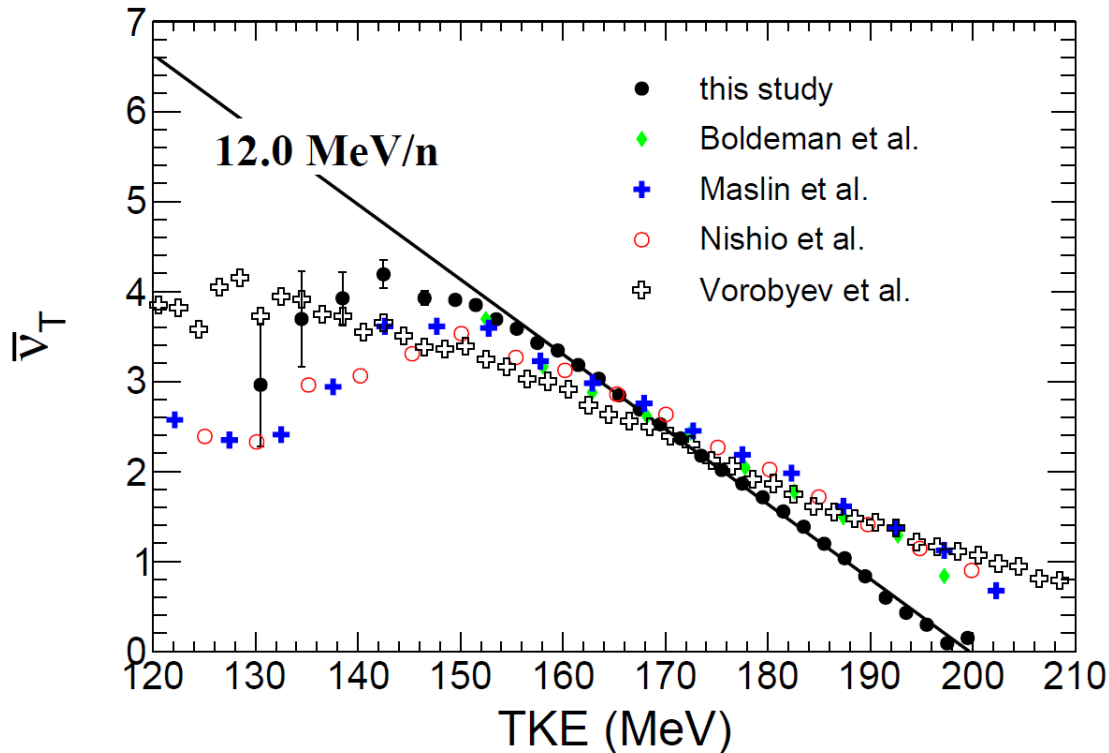

Close to linear dependence

$$-\frac{dTKE}{d\bar{\nu}_T} = 12.0 \text{ MeV/n}$$

The slope is much steeper than earlier studies

$$-\frac{dTKE}{d\bar{\nu}_T} = 16.7 - 18.5 \text{ MeV/n}$$

The difference cannot be explained by difference in incident neutron energy

Statistics ~ 500000 events

Multiplicity vs. Fragment TKE

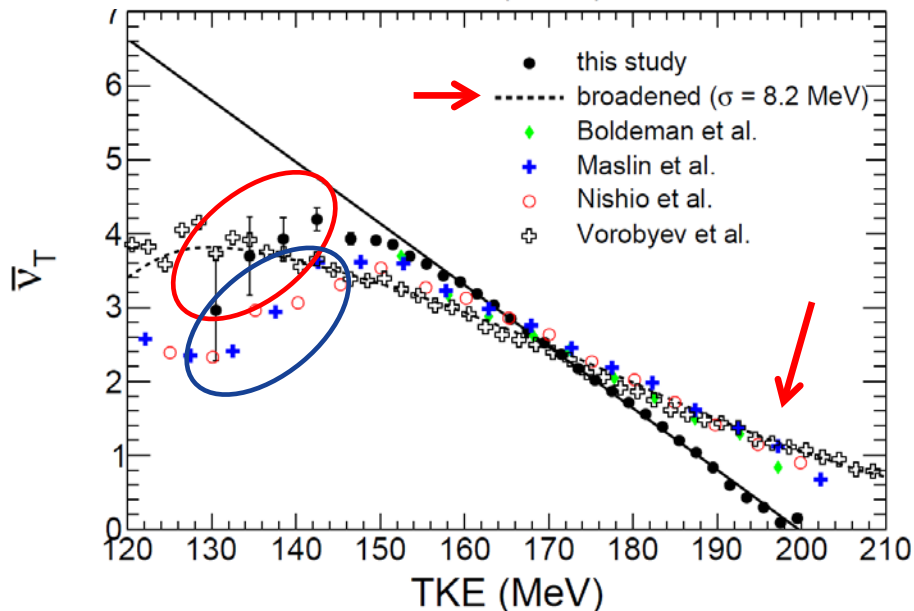
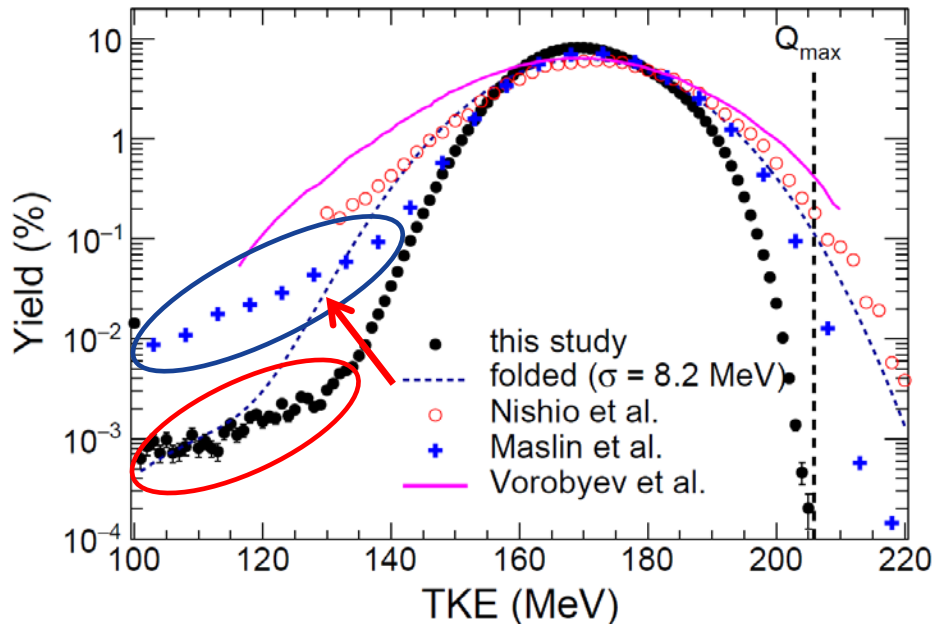

- Wide TKE-distributions
- Significant Yield at $TKE > Q_{\max}$
- ⇒ Resolution broadening
- Decreased slope
- Increased neutron yield at Q_{\max}

Tailing of TKE distribution

- Energy degraded scattered fission fragments
- Neutron yield should approach average nubar
- Drop in nubar at low TKE
- Present also in our data

VERDI design (2E-2v detector)



Energy

- 2 arrays of 16 Si detectors
- Pairs facing each other
- Each detector 450 mm²

Time-of-Flight

- **Start:** Electrons emitted from target detected by Micro Channel Plate (MCP)
- **Stop:** Si detector

- Maximum solid angle coverage (0.5% of 4π) at relatively short flight path (50 cm)
- Excellent energy (0.5%) and timing resolution (150 ps)
- Energy losses only in target backing and silicon detector dead layer

^{252}Cf Measurements - energy

Pre-neutron kinetic energy

Agrees well

Göök $\langle \text{TKE} \rangle = 184.1 \text{ MeV}$

VERDI $\langle \text{TKE} \rangle = 184.1 \text{ MeV}$

(perfect match)

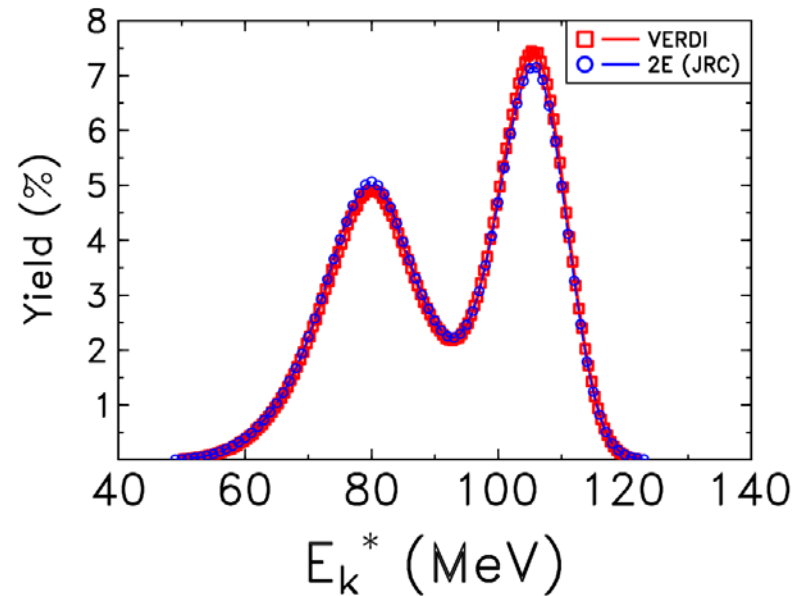

Post-neutron kinetic energy

Agrees well

Göök $\langle \text{TKE} \rangle = 181.4 \text{ MeV}$

VERDI $\langle \text{TKE} \rangle = 181.1 \text{ MeV}$

(within 0.2%)

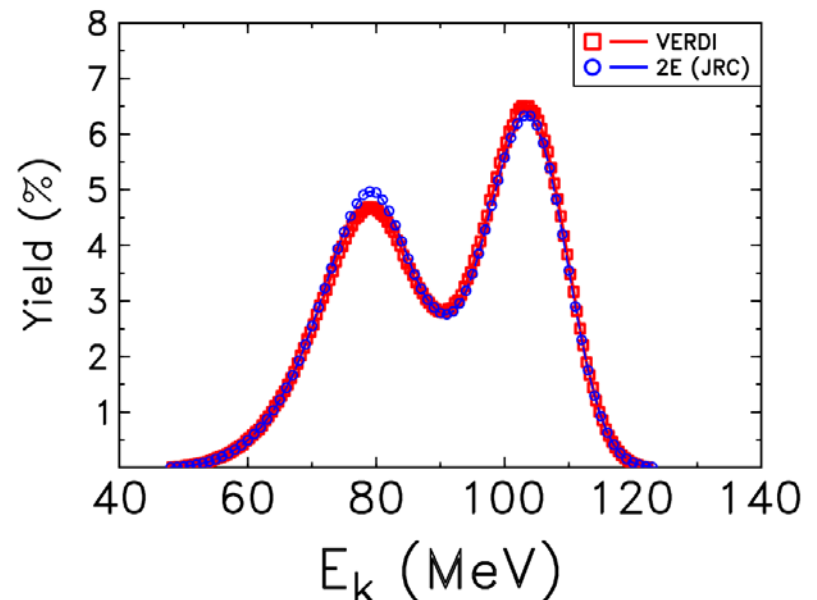

^{252}Cf Measurements - mass

Pre-neutron mass

- ✓ Agrees well with results obtained with the double-energy technique
- ✓ Better resolution due to the good timing resolution of the MCPs
- ✓ more structure around maximum yields

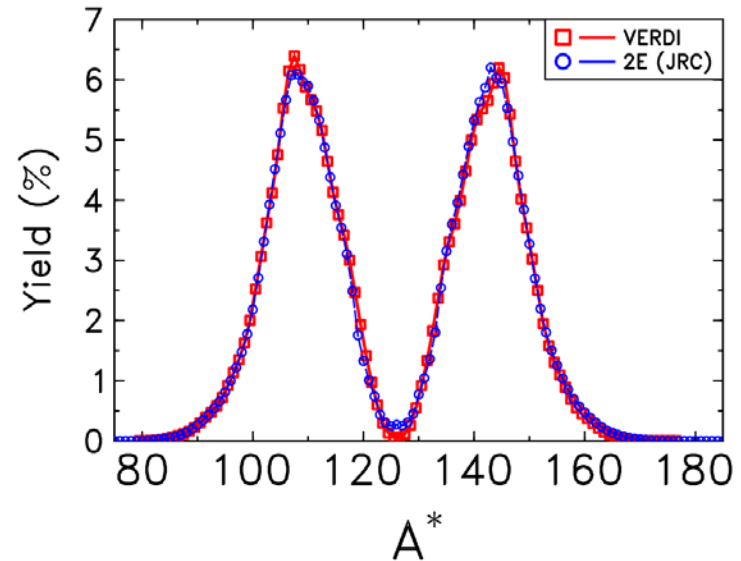

Post-neutron mass

- ✓ Agrees well with results obtained with the double-energy technique
- ✓ Small discrepancy around heavy peak

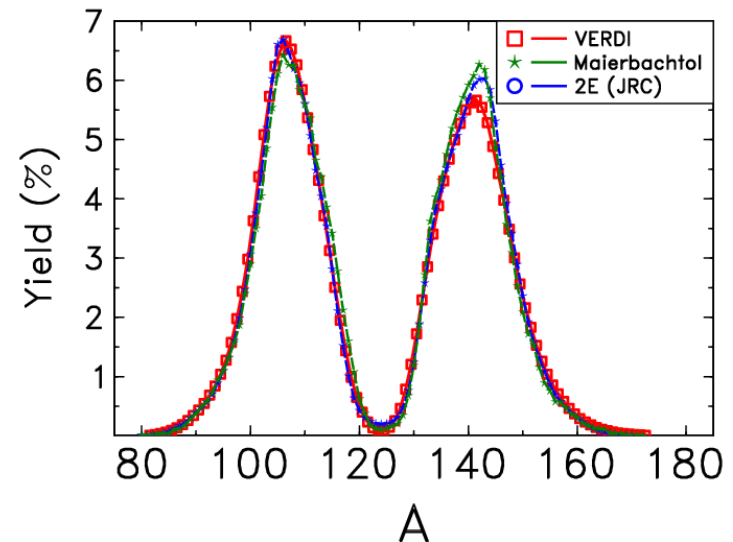

^{252}Cf Measurements - $\langle \nu \rangle (A)$

Average neutron multiplicity

- => Difference between pre and post mass
 - ✓ $\langle \nu \rangle$ within 2.2% of recommended value (3.759)!
 - ✓ Independent method to determine mass-dependent prompt neutron multiplicity data
- Differences around mass symmetry
 - Pointing to an improved post mass resolution
 - $\Delta A \sim 2 u$
- Problems
 - Diffusion of Cf material into backing
 - 250 nm Ni much thicker than our standard PI backings
 - Correction for plasma defects in Si detectors

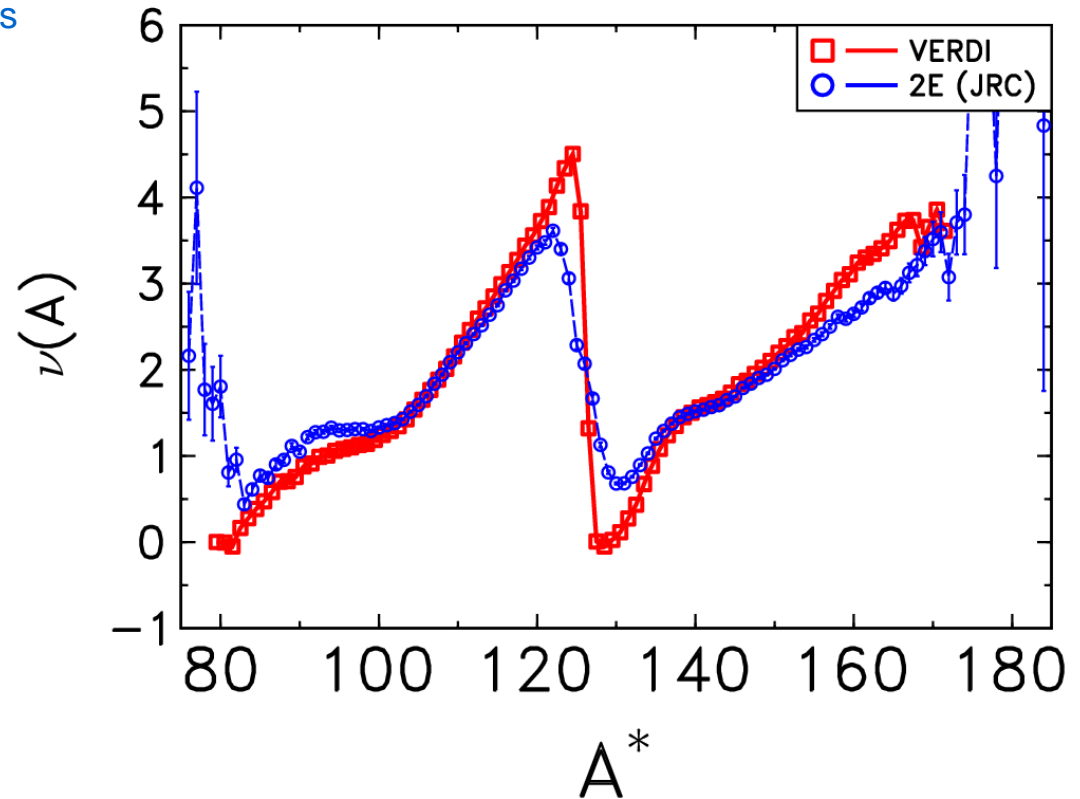

Conclusions

- Improved modelling require **better and more detailed experimental data** especially **correlation data** of fission fragments with prompt neutron and γ -ray emission
- Prompt neutron and prompt γ -emission data **are difficult** to measure
- Digital data acquisition and analysis shows **definite advantages**
- The **saw-tooth shape** of the average number of neutrons emitted per fragment for ^{235}U **shows more pronounced minima** at $A_H=130$ u and $A_L=80$ u
- The **TKE dependence** of the number of neutrons emitted per fission shows an **inverse slope $d\text{TKE}/dv$ ca. 35% weaker than observed in earlier studies**. The difference can be **explained by improved fission fragment TKE resolution** in the present experiment
- The 2E-2v detector **VERDI shows improved resolution and promising results**, although some issue are still persisting

Prompt fission gamma-ray measurements $^{239}\text{Pu}(n_{\text{th}},f)$

- Prompt fission gamma-rays – reference spectral data and energy dependence
- Physical Review C accepted paper, Gatera et al.
- ✓ PhD thesis of Angélique Gatera (JRC Geel)
 - ✓ [High priority data request from OECD Nuclear Energy Agency](#)
 - ✓ [Data included in JEFF-3.3T3 and ENDF/B-VIII](#)

< 2.4%

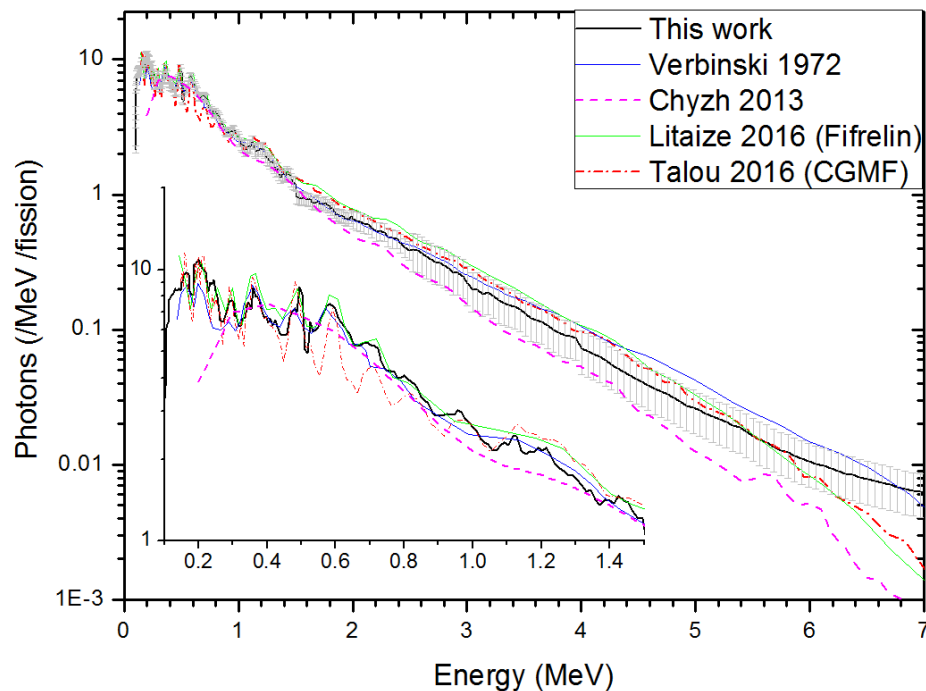

Prompt fission gamma-ray characteristics from the reaction $^{239}\text{Pu}(n_{\text{th}},f)$

Results	Detector	Diameter × length (cm × cm)	\bar{M}_γ (per fission)	ϵ_γ (MeV)	$E_{\gamma,\text{tot}}$ (MeV)	Energy range (MeV)
This work	LaBr ₃ :Ce (Q489)	5.08 × 5.08	7.27 ± 0.11	0.85 ± 0.02	6.48 ± 0.10	0.1 - 7.0
This work	LaBr ₃ :Ce (5414)	5.08 × 5.08	7.35 ± 0.11	0.84 ± 0.02	6.17 ± 0.05	0.1 - 7.0
This work	LaBr ₃ :Ce (5415)	5.08 × 5.08	7.26 ± 0.11	0.88 ± 0.02	6.42 ± 0.10	0.1 - 7.0
This work	LaBr ₃ :Ce	Averaged spectrum	7.35 ± 0.12	0.85 ± 0.02	6.27 ± 0.11	0.1 - 7.0

TABLE II. Detailed contributions to the total uncertainties of prompt fission γ -ray characteristics given in Tab. I. The two first lines show absolute contributions to the total uncertainties and the 3 last lines detail relative contributions to the systematics.

Type of uncertainty	\bar{M}_γ (/fission)	ϵ_γ (MeV)	$E_{\gamma,\text{tot}}$ (MeV)
Statistical (fission, simulation, γ -ray)	0.004	0.002	0.018
Systematics	0.109	0.017	0.083
(i) Simulation (setup, cross section)	84.2 %	76.4 %	70.5 %
(ii) Energy calibration	-	1.6 %	2.2 %
(iii) Fitting detector response	15.8 %	22.0 %	27.3 %

Energy dependence of prompt fission gamma-ray characteristics

PFGS characteristics from $^{240}\text{Pu}(\text{sf})$ and $^{242}\text{Pu}(\text{sf})$;

First experimental data ever: Physical Review C 93, 054603 (2016)

Data to IAEA Nuclear Data section for inclusion in EXFOR data base

Data to LANL T2 Theory Division to benchmark de-excitation code CGMF

PFGS characteristics from $^{239}\text{Pu}(\text{n}, \text{f})$ at $\langle E_n \rangle = 1.7$ MeV: measurement performed within CHANDA TAA at the LICORNE directional fast neutron beam (IPN Orsay, FR)

Scientific support provided to a PhD thesis at the Université Sud de Paris. $^{235}\text{U}(\text{n}, \text{f})$ PFGS at resolved resonance-neutron energies measured and data analysis on-going

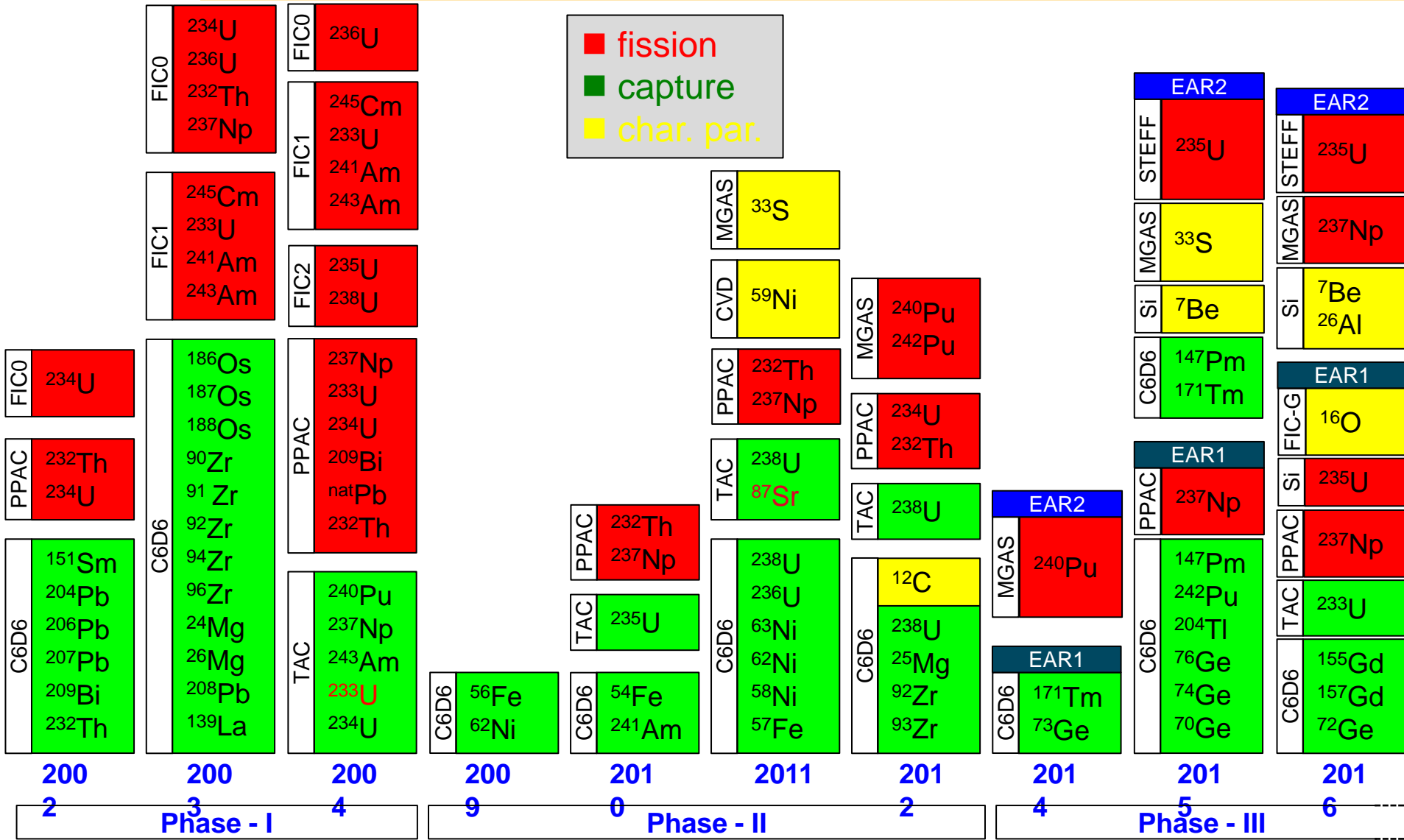



UPPSALA
UNIVERSITET

Measurement of nubar(A,E) and PFNS for ^{235}U and ^{237}Np at IRMM

A. Al Adili¹, A. Gök², K. Jansson¹, F.-J. Hamsch², S. Oberstedt², V. Rakopoulos¹, A. Solders¹, D. Tarrío¹, S. Pomp¹

¹Uppsala University, Sweden ²JRC-IRMM, Belgium

- Aim:** Measure nubar and PFNS as function of energy and mass for various targets
- Method:** Frisch-Grid Ionization Chamber + neutron detectors from SCINTIA setup
- Data:** First measurements with thermalized neutrons from IRMM Van De Graaff. New run at higher energy (5.5 MeV) accepted by EUFRAT.

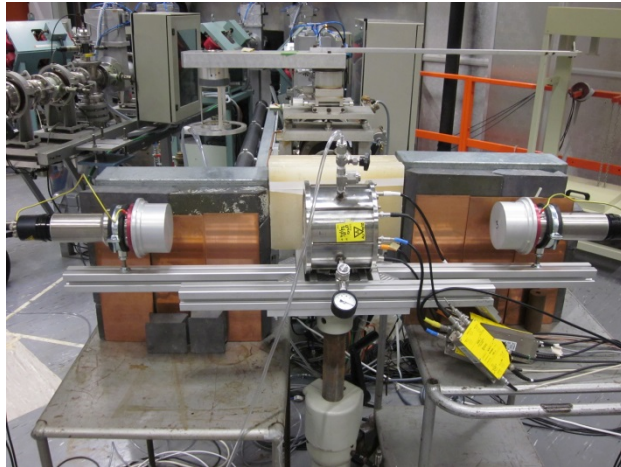

Setup with FGIC, 2
neutron detectors,
moderator and
shielding

Test result for ^{252}Cf :
nubar(A) and nubar vs TKE
Red: this exp.
Black: A. Gök et al.

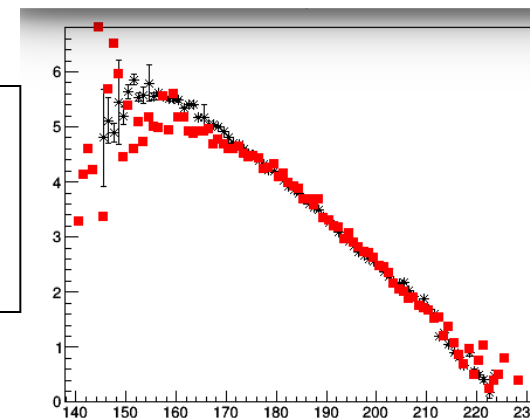
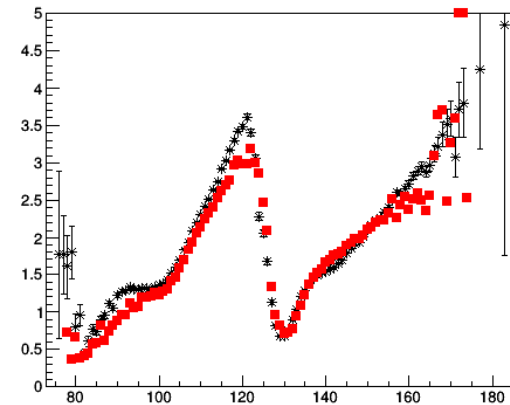

See A. Al-Adili et al., ND2016 conference proceedings.



UPPSALA
UNIVERSITET

Measuring FF properties with the VERDI (2E-2v) spectrometer at GELINA

K. Jansson¹, S. Oberstedt², M.-O. Fregeau^{2,3}, A. Al Adili¹, C. Gustavsson¹, F.-J. Hamsch², D. Tarrío¹, S. Pomp¹, et al.

¹Uppsala University, Sweden ²JRC-IRMM, Belgium ³GANIL, France

- Aim:** Develop VERDI and measure FF properties via the 2E-2v method.
Method: VERDI spectrometer at GELINA facility.
Status: Proof of principle using both arms (individual timing information). Test case: Cf(sf).



Two arms with
one MCP and 16 Si each

In black: preiim. Results for ²⁵²Cf(sf)
In red: data from A. Gök et al.

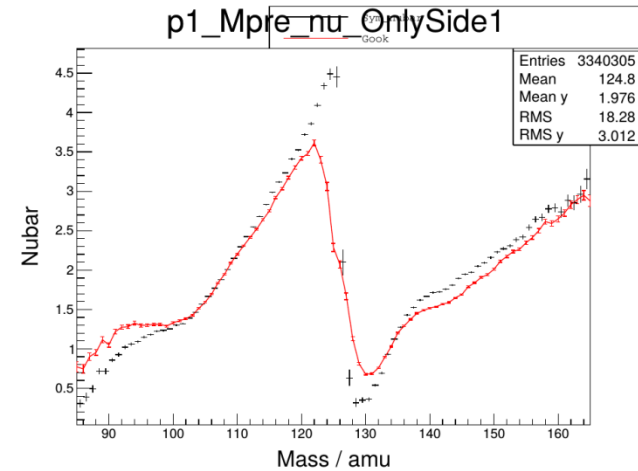
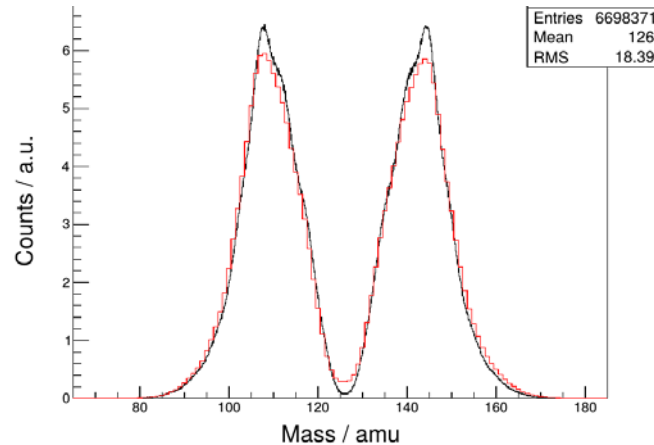

See K. Jansson et al., ND2016



Medley@NFS:

Light-ion production, fission fragment angular distribution and fission cross section measurements relative to elastic np scattering

D. Tarrío, A.V. Prokofiev, S. Pomp, C. Gustavsson, K. Jansson, E. Andersson Sundén

- Aims:**
- (1) Light-ion production studies from various targets.
 - ➔ 21 shifts for $^{12}\text{C}(n,\text{lcp})$ accepted by PAC in the first call for NFS
 - (2) Simultaneous measurement of cross sections for $\text{H}(n,n)$, $^{235}\text{U}(n,f)$, and $^{238}\text{U}(n,f)$ over the energy range of the future "white" neutron beam at NFS.
- Goal:** For standard cross section: High-quality data (uncertainties below 2%)

D. Tarrío et al., proceedings ND2016
 K. Jansson et al., NIM A794 (2015) 141

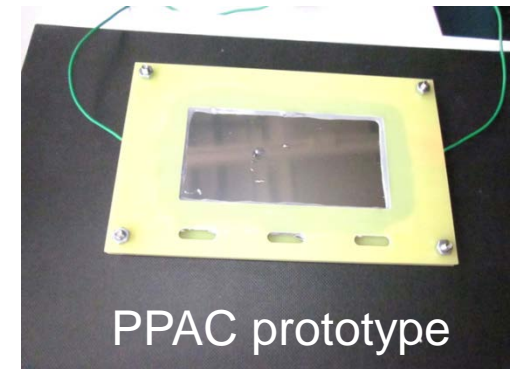
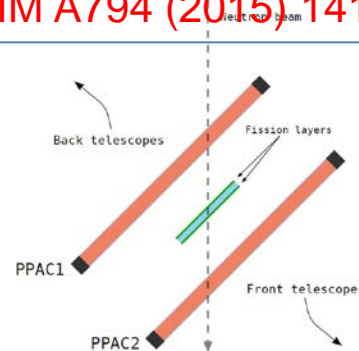
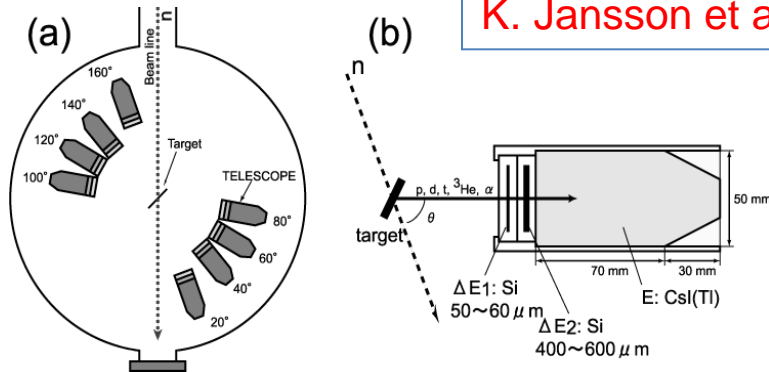

The existing Medley setup is being upgraded with PPACs to allow neutron ToF measurements. A gas system for the chamber is operational. The targets are under development within the CHANDA project.

The beam time at NFS for accepted experiment is expected in early 2018.



Measuring neutron-induced independent fission yields and isomeric ratios at IGISOL + JYFLTRAP

UPPSALA
UNIVERSITET

M. Lantz, A. Mattera, V. Rakopoulos, A. Solders, A. Al Adili, S. Pomp, A. Prokofiev, and the JYFL IGISOL team

Goal: Obtain high quality data for better understanding of the fission process and for better use of resources in present and future nuclear systems.

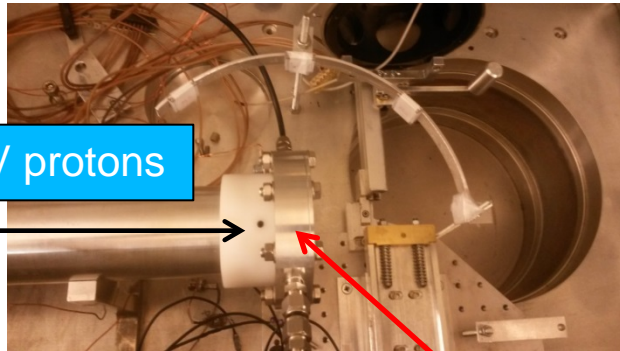

Characterization of $\text{Be}(p, xn)$ neutron field with activation plates.

Total flux of fast neutrons (>1 MeV) of $2-3 \times 10^{12}$ n/sr/s can be achieved.

A. Al Adili et al., EPJA (2015) 51:59
V. Rakopoulos et al., proceedings ND2016
A. Solders et al., proceedings ND2016
A. Mattera et al., EPJA (2017) submitted

Performed:

- First direct measurement of **Isomeric Yield Ratios** by direct ion counting in (p,f)
- Several isomeric pairs in $^{238}\text{U}(p,f)$ and $\text{Th}(p,f)$ measured for the first time.
- **Dec 2016: first data on $^{238}\text{U}(n,f)$**
 - Based on gamma spectroscopy
 - Mass region 129-133
 - Manuscript in progress

Next steps:

- More IYR also for (n,f), go for JYFLTRAP
- Implement Phase imaging technique -> mass resolving power corresponding to <50 keV is reachable. Test this for (p,f).



UPPSALA
UNIVERSITET

Measuring ${}^6\text{Li}$ (n, α) at IRMM with the GELINA white spectrum neutron source

K. Jansson¹, A. Al Adili¹, C. Gustavsson¹, F.-J. Hambsch², S. Oberstedt², D. Tarrío¹, S. Pomp¹, et al.

¹Uppsala University, Sweden ²JRC-IRMM, Belgium

Aim: Measure ${}^6\text{Li}(n,\alpha)$ cross section up to several MeV for extension of neutron standard
Method: Twin Frisch-Grid Ionization Chamber (with P-10) at GELINA facility using LiF targets and U-235 as reference; digital DAQ

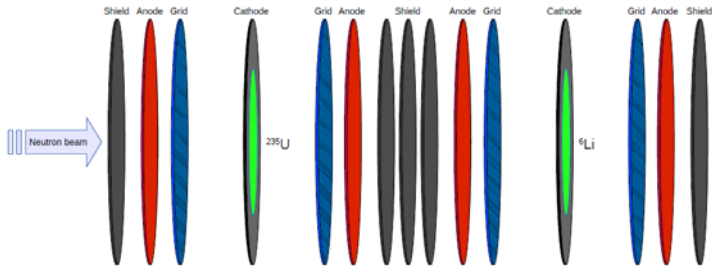

TFGIC with U-235 and LiF target (common (upper) and individual (lower) chambers

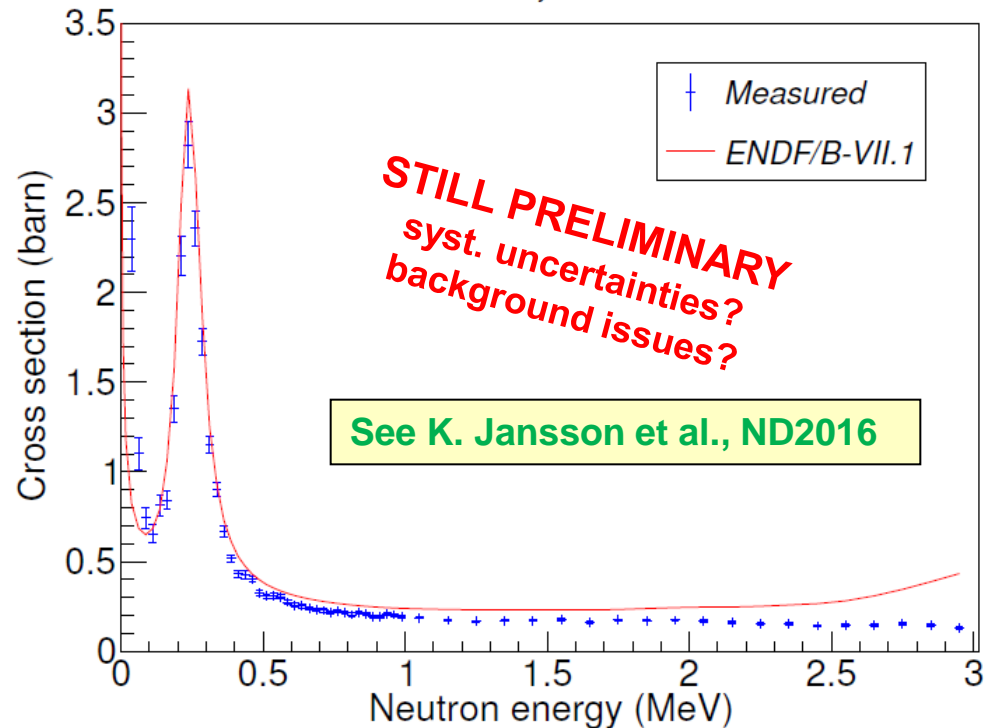
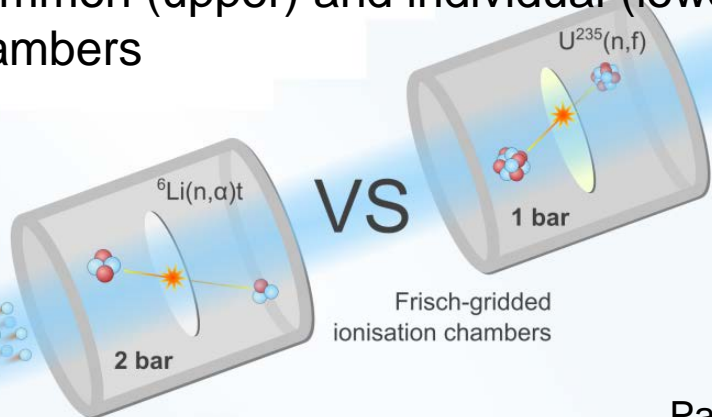

NEEDS/NACRE/EEDIN

Study of $(n, xn \gamma)$ reactions

Status and prospects of the EEDIN collaboration

Greg Henning, Maëlle Kerveno, Philippe Dessagne, Eliot Party
(CNRS/IPHC – Université de Strasbourg)

Marc Dupuis, Stéphane Hilaire, Pascal Romain

(CEA/DAM – Bruyères le Châtel)

Cyrille de Saint-Jean, Pierre Leconte, David Bernard

(CEA/DEN- Cadarache)

$^{238}\text{U}(n, xn \gamma)$ cross sections – *preliminary*

Ground state rotational band

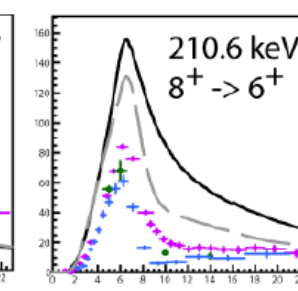
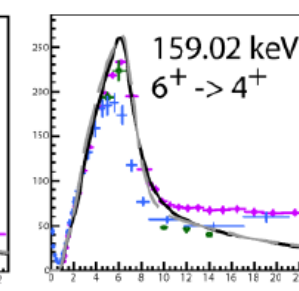
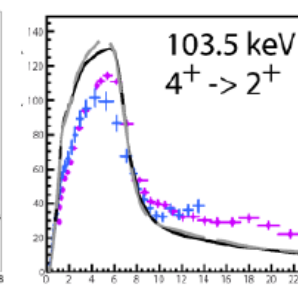
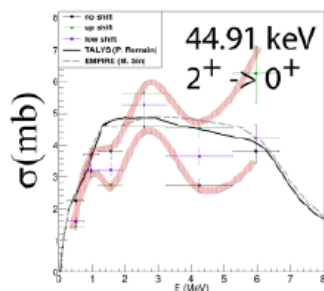

- TALYS (P. Romain)
- EMPIRE (R. Capote)
- Fotiades (2004)
- Hutcheson (2009)
- Voss (1979)
- Olsen (1979)
- IPHC (prelim.)

E_n (MeV)

Band 2

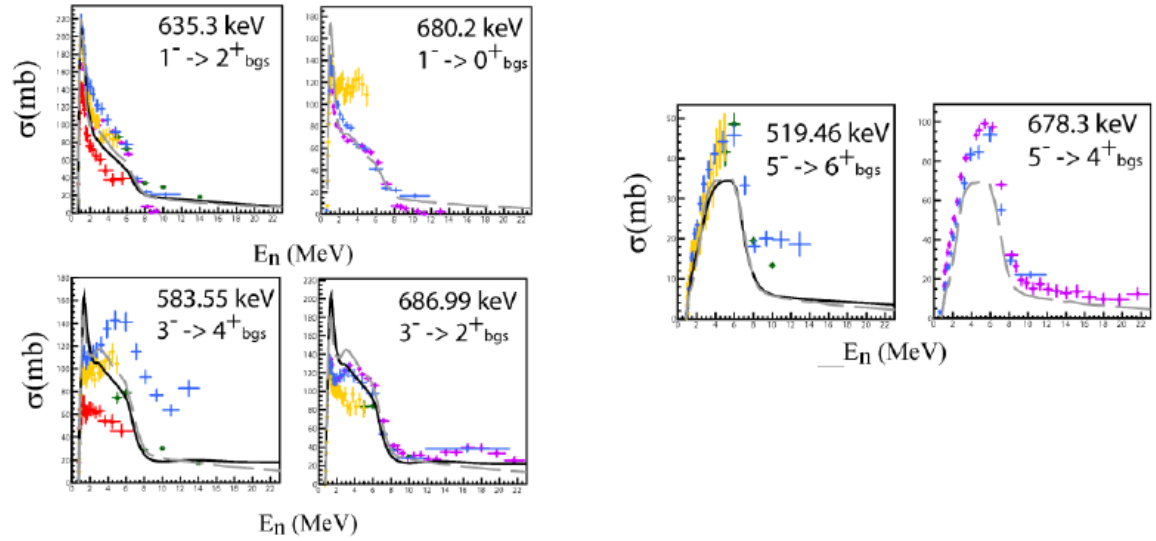

Band 3

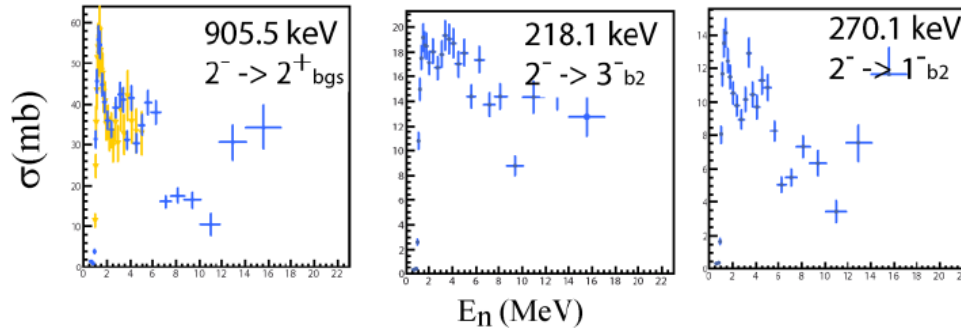

Band 6

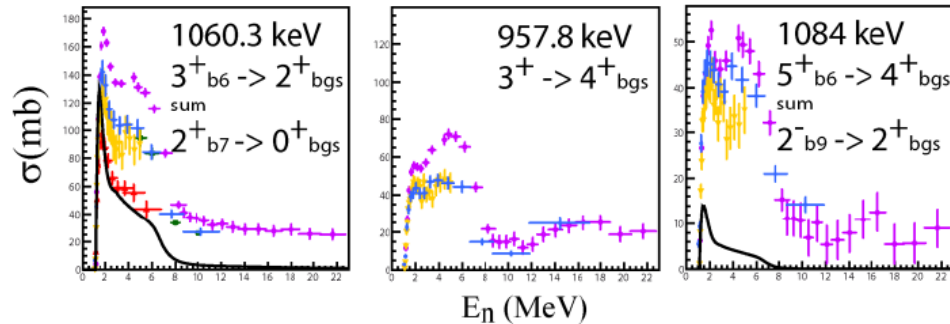

Calculations and integral experiments

Calculations – by CEA/DAM

Microscopic approach in the entrance channel greatly impacts the spin distribution and fixes discrepancies for high spins ground state rotational band transitions.

Also looking into gamma-strength and level density impact.

From other isotopes (W), the number of discrete levels used in calculations also plays a role.

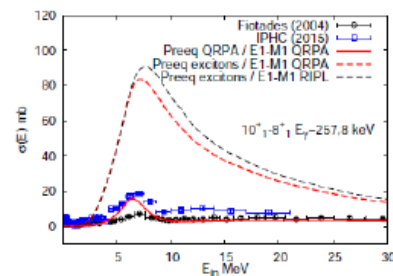
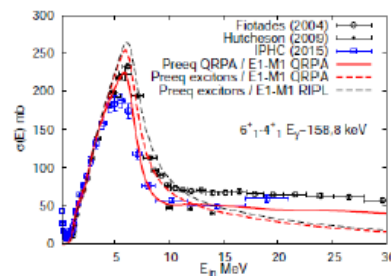
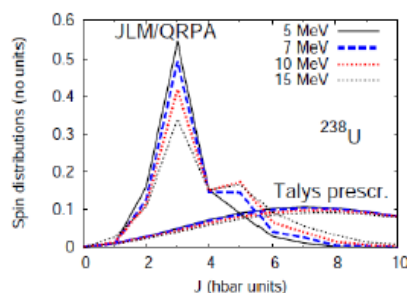

Perspectives: ^{233}U

Experiment

Upgraded GRAPhEME setup
(5 planar HPGe detectors + 36 pixels)
Target: 8.3 grams of ^{233}U (~3 Gbq)

2500 hours of dat recorded, and still going...

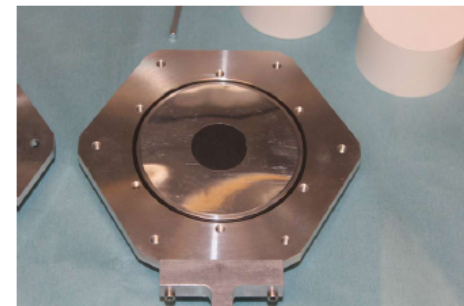

Absolute cross section measurements of neutron-induced fission of ^{242}Pu from 1 to 2.5 MeV

C. Matei, F. Belloni, J. Heyse, A. J. M. Plompen, and D. J. Thomas

Phys. Rev. C 95, 024606 – Published 14 February 2017

ELI-NP/IFIN-HH, JRC-Geel, NPL

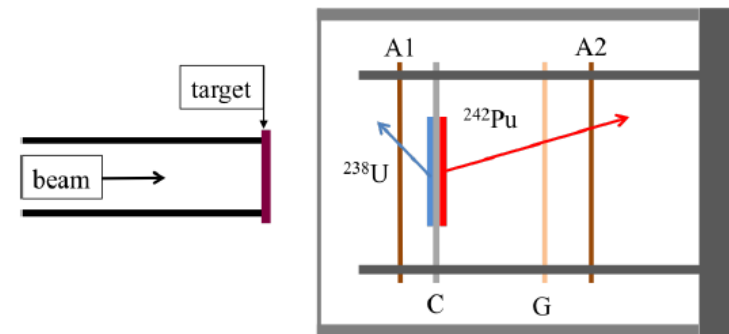

^{242}Pu	
Production method	Molecular plating
Chemical composition	$\text{Pu}(\text{OH})_4$
Diameter (mm)	29.95 ± 0.03
Activity (MBq)	0.0915 ± 0.0003
Mass (μg)	625 ± 5
Areal density ($\mu\text{g}/\text{cm}^2$)	88.7 ± 0.8
Isotopic purity	99.96518(45)%

TABLE II. Summary of evaluated and experimental data on the spontaneous fission half-life of ^{242}Pu .

Evaluation/Experiment	$T_{1/2}^{SF}$
Holden (2000) [17]	$(6.77 \pm 0.07) \times 10^{10}$
Chechev (2005) [18]	$(6.79 \pm 0.09) \times 10^{10}$
Salvador-Castineira (2013) [16]	$(6.74 \pm 0.08) \times 10^{10}$
This experiment	$(6.72 \pm 0.09) \times 10^{10}$

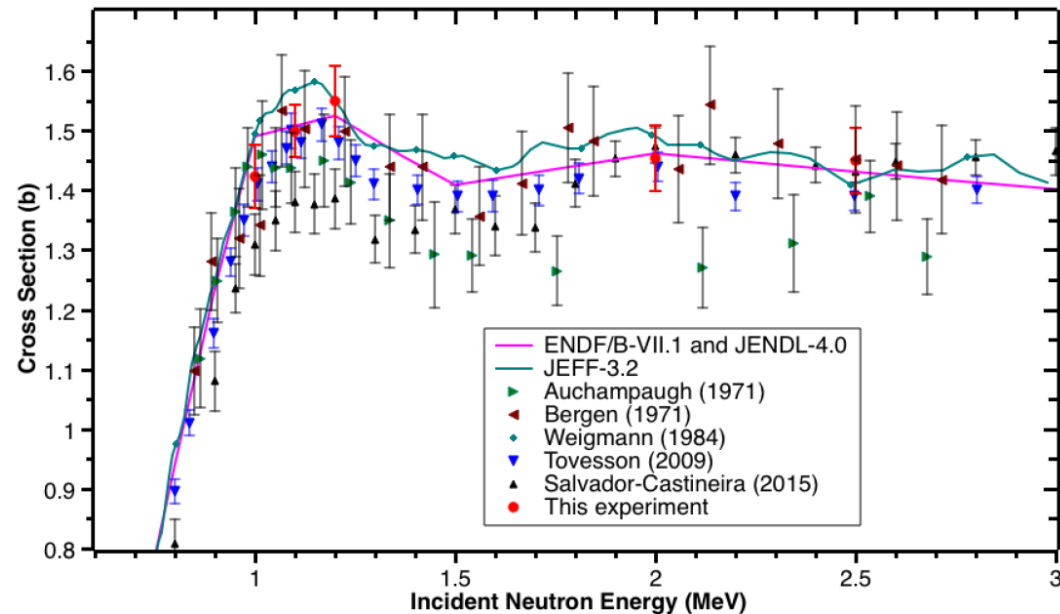

TABLE III. Calculated neutron fluences with standard uncertainties, neutron beam attenuation, and target scattering correction at the chosen neutron energies.

Energy (keV)	1001	1100	1200	2000	2500
Fluence ($\times 10^9 \text{ cm}^{-2}$)	2.56	2.81	2.10	4.95	4.02
Standard uncertainty (%)	3.3	2.5	3.4	3.4	3.4
Target scattering (%)	2.9	2.9	3.0	1.8	1.5
Beam attenuation (%)	96.8	96.8	96.8	97.1	97.1

Backward-forward reaction asymmetry of neutron elastic scattering on deuterium

E. Pirovano, R. Beyer, A. R. Junghans, N. Nankov, R. Nolte, M. Nyman, and A. J. M. Plompen; Phys. Rev. C 95, 024601 – Published 2 February 2017
 JRC-Geel, HZDR (expt at HZDR)



TABLE II. Physical properties of the samples.

	CD ₂	graphite
diameter (cm)	7.00(2)	11.0(1)
thickness (cm)	0.30(2)	0.93(2)
areal density (g/cm ²)	0.3236(9)	1.52(1)

99.999% ²H/H; Raghu Rao, AECL, 40 kCD

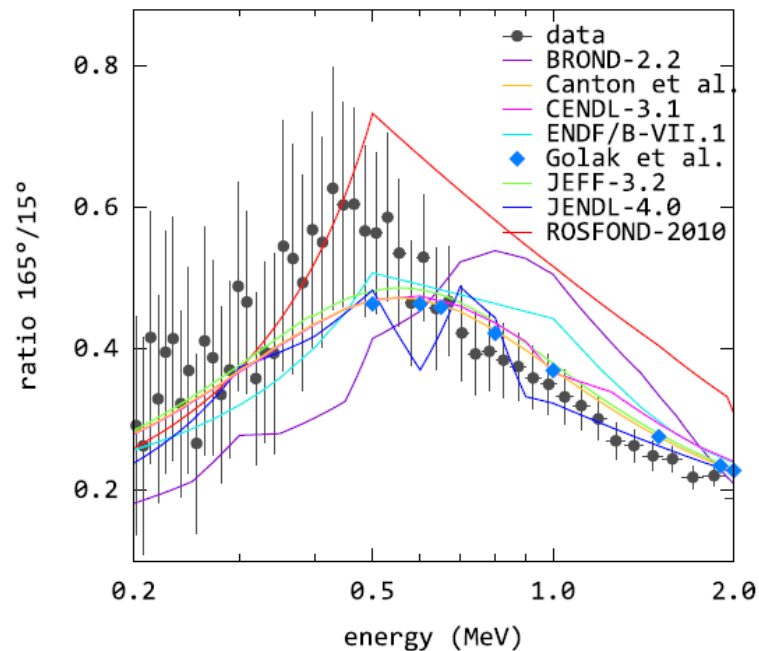
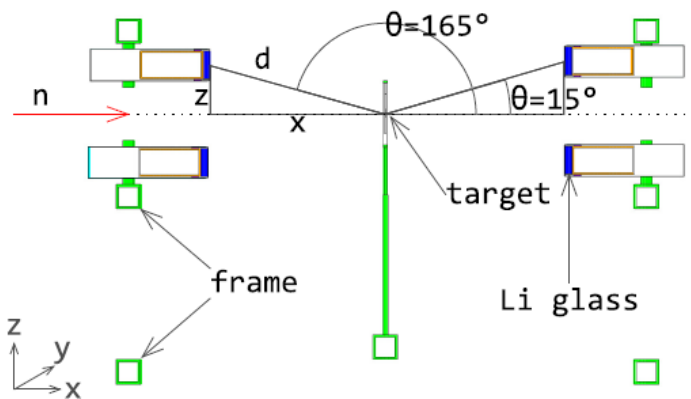

Neutron scattering data (Pirovano)

New setup developed.

Data in preparation for $n+C$ and $n+Fe$ (2-5 MeV).



Measurement of the 477.6-keV γ -ray production cross section following inelastic neutron scattering by ${}^7\text{Li}$

M. Nyman, F. Belloni, D. Ichinkhorloo, E. Pirovano, A.J.M. Plompen and C. Rouki, Physical Review C 93, 024610 (2016)

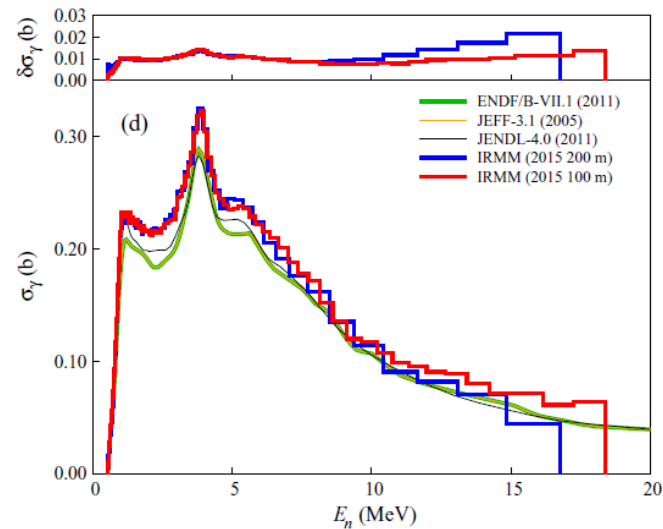
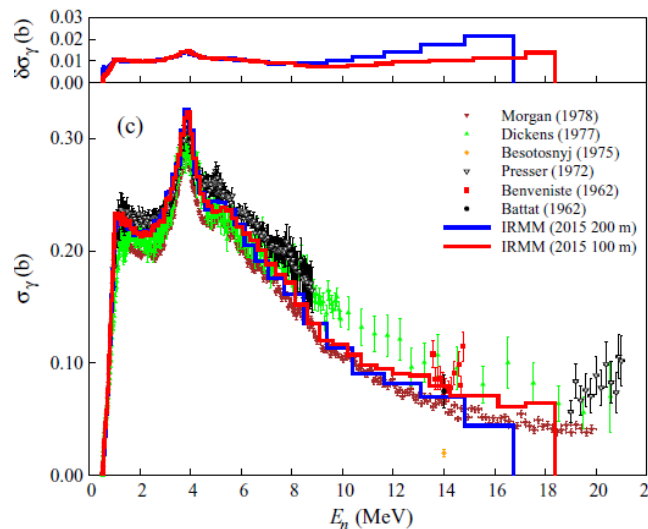
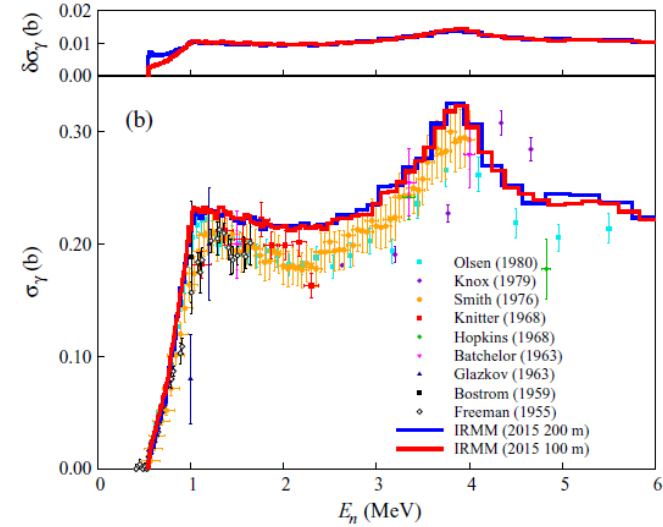
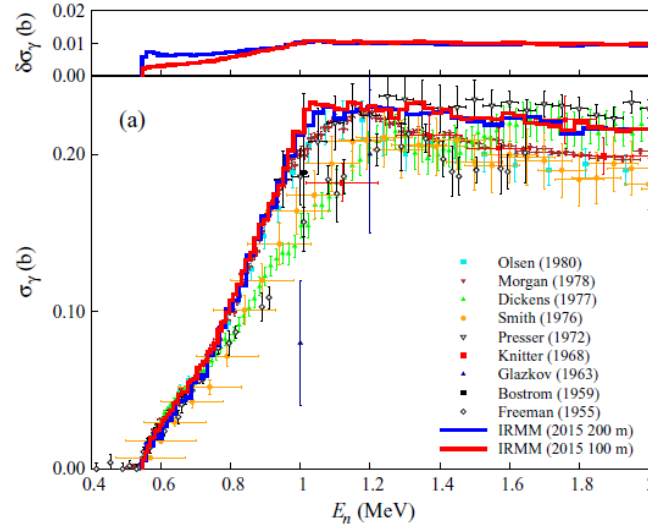
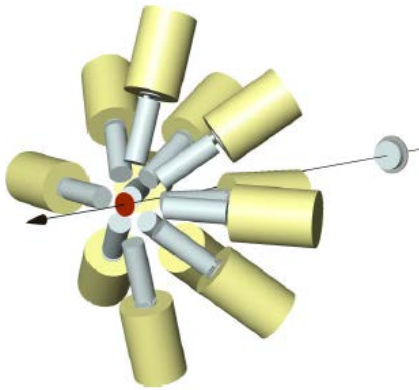

With IFIN-HH and U. Bucharest

Papers in preparation on GAINS data for

- $^{57}\text{Fe}(n,n'g)$
- $^{48}\text{Ti}(n,n'g)$ + minor isotopes

$^{48}\text{Ti}(n,n'g)$ data contributed to standards project IAEA, as was case for $^7\text{Li}(n,n'g)$.

With IRSN and IFIN-HH new experimental data taken for $^{54}\text{Fe}(n,n'g)$.

(n,tot) on ^{16}O

- Neutron transmission through liquid oxygen, $E_n=20\text{-}35\text{MeV}$
- Monoenergetic peak decrease measured using TOF selection

TOF matrix, protons on Li, 22.5 MeV, NE213 at 4.39 m

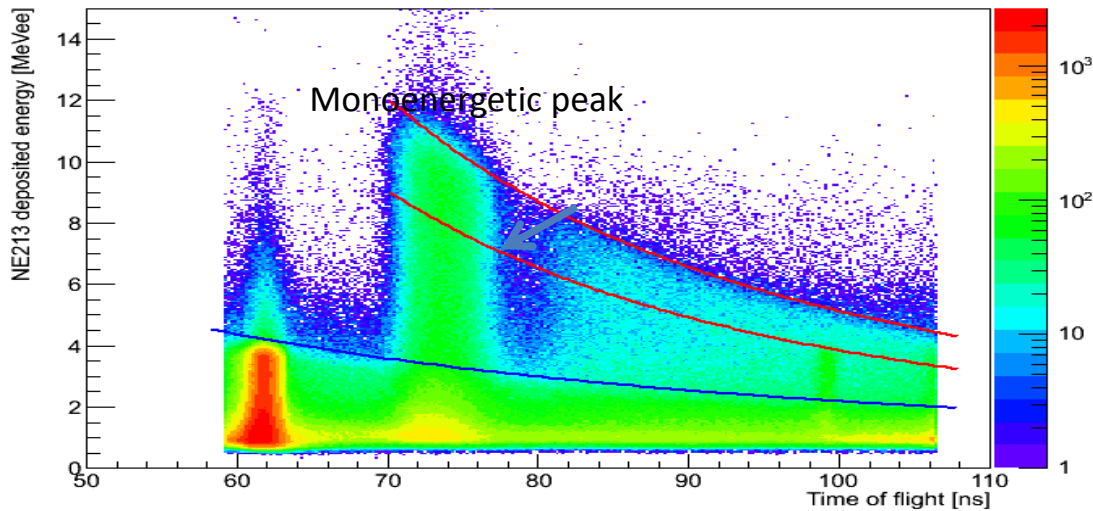

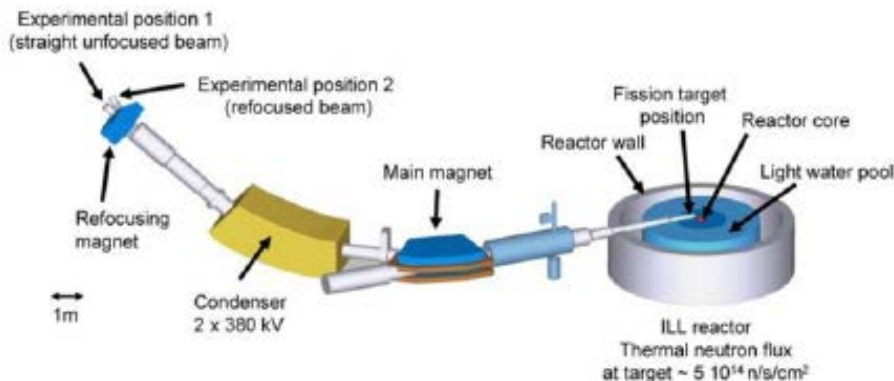

The fission fragment separator 'Lohengrin' @ the high-flux reactor of the Institute Laue Langevin in Grenoble (France)
Collaboration between LPSC / ILL / CEA

Example: $^{239}\text{Pu}(n_{th},f)$

- Mass range covered: **[126-150]**

$$\sum_{126}^{150} Y_{Loh} = \mathbf{96.69\%}$$

- Strong reduction of the uncertainties compared to JEFF-3.1.1 library:
below 5% between [126-146]

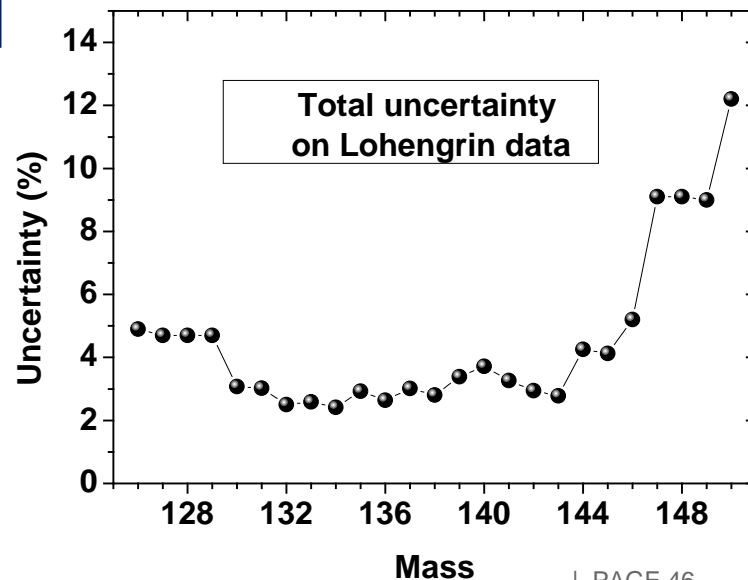
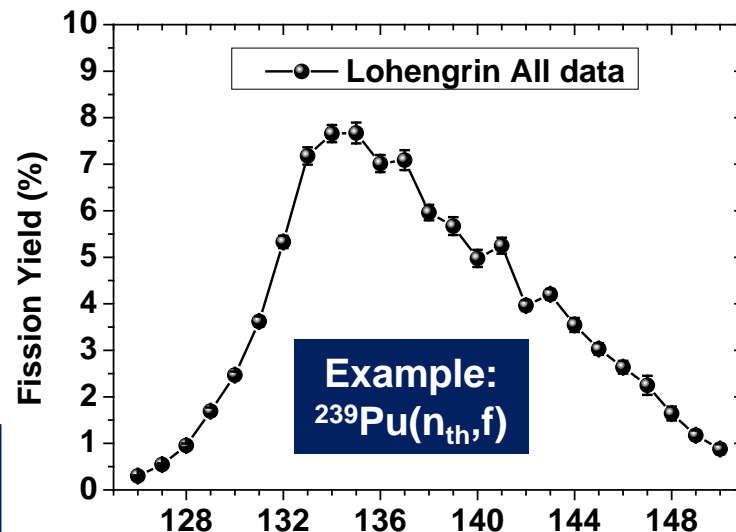

Ternary fission yield from $^{241}\text{Pu}(n, f)$ reaction

Serot, Heyse, Wagemans

Ternary particles: important source of tritium production in nuclear reactors and in used fuel elements:

- Direct contribution from ^3H ternary particles
- Indirect contribution from ^6He ternary particles

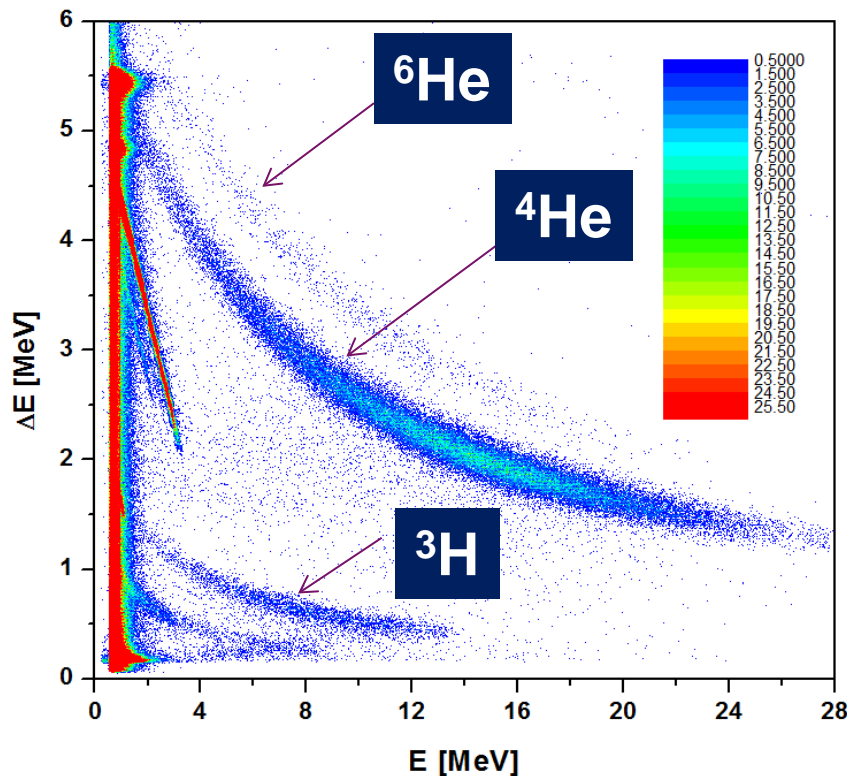

Measurement performed at the
Budapest Research Reactor

Olivier SEROT,
CEA-Cadarache, France
Jan HEYSE, Andre MOENS
EC-JRC-Geel, Belgium
Tamas BELGYA, Zoltan KIS
Centre for Energy Research, Budapest,
Hungary

$$^6\text{He}/B = (4.48 \pm 0.30) \times 10^{-5}$$

DE LA RECHERCHE À L'INDUSTRIE



STATUS OF THE UO₂ MEASUREMENTS AT ILL FROM ROOM TO 900 K

G. Noguere, J.P. Scotta, A. Filhol, J. Ollivier, E. Farhi, Y. Calzavarra

16-18 May 2017

2010

⇒ Light and heavy water in IN5 and IN4 at ILL in **cold operating conditions**

- H₂O: 285 K, 290 K, 294 K, 300 K, 302 K, 311 K, 323 K (P = 1bar)
- D₂O: 250 K (ice), 295 K, 296 K, 325 K

2015

⇒ Light and heavy water in IN6 and IN4 at ILL in **hot operating conditions**

- T = 300 - 540 K and P=1 - 600 bar

2016

⇒ Measurement of the double-differential neutron cross section of U in UO₂ in IN6 and IN4 **from room temperature to Hot Full Power conditions**

- T = 294 K, 600 K et 900 K

Objectives of the experimental program

- Experimental validation of the new NCSU evaluation
- Comparison MCNP/TRIPOLI calculations
- Recommendation of effective temperatures for PWR calculations

Sample	Neutron energie	Temperature	Time	Run
UO ₂	111,9 meV (0,855 A)	290,15 K (17°C)	12h	88121-88144
	111,9 meV (0,855 A)	591,15 K (318°C)	12h31min	88146-88171
	111,9 meV (0,855 A)	901,8 K (628,65°C)	12h	88174-88197
	66.4 meV (1,11 A)	902,15 K (629°C)	7h46min	88198-88213
	111,9 meV (0,855 A)	296,15 K (23°C)	3h57min	88257-88264
	66.4 meV (1,11 A)	296,15 K (23°C)	2h46min	88265-88270
Vanadium	66.4 meV (1,11 A)	288,18K (15°C)	1h30min	88396-88398
	111,9 meV (0,855 A)	287,15K (14°C)	4h02min	88399-88407
Dummy	111,9 meV (0,855 A)	290,15K (17°C)	6h	88468-88479
	111,9 meV (0,855 A)	598,15K (326°C)	6h	88482-88493
	111,9 meV (0,855 A)	905,15K (632°C)	6h	88496-88507
	66.4 meV (1,11 A)	905,15K (632°C)	3h	88508-88513
	66.4 meV (1,11 A)	306,15K→297,15K 33°C→24°C	4h58min	88542-88551

Two energies

- 66 meV
- 112 meV

Three temperatures

- T=300 K
- T=600 K
- T=900 K

Sample	Neutron energie	Temperature	Time	Run
UO ₂	3 meV (5,12 A)	336,15K→324,15K (63°C→51°C)	20h	189008 - 189048
	3 meV (5,12 A)	584,15K (311°C)	7h	189049-189062
	3 meV (5,12 A)	888,15K (615°C)	6h	189064-189075
	3 meV (5,12 A)	306,15K→302,15K (33°C→29°C)	12h30min	189233-189257
	3 meV (5,12 A)	587,15K 314°C	6h30min	189259-189271
	3 meV (5,12 A)	890,15K (614°C)	12h30min	189272-189296
Vanadium	3 meV (5,12 A)	304,55K (31,4°C)	2h30min	189094-189098
Dummy	3 meV (5,12 A)	302,68K (29,53°C)	18h	189101-189136
	3 meV (5,12 A)	594,15K (321°C)	15h	189138-189167
	3 meV (5,12 A)	598K (324,85°C)	18h	189169-189204

Energy : 3 meV

Three temperatures

- T=300 K
- T=600 K
- T=900 K

Double differential cross section at room temperature

⇒ simple comparison with ddxs calculated with the $S(\alpha,\beta)$ established by NCSU

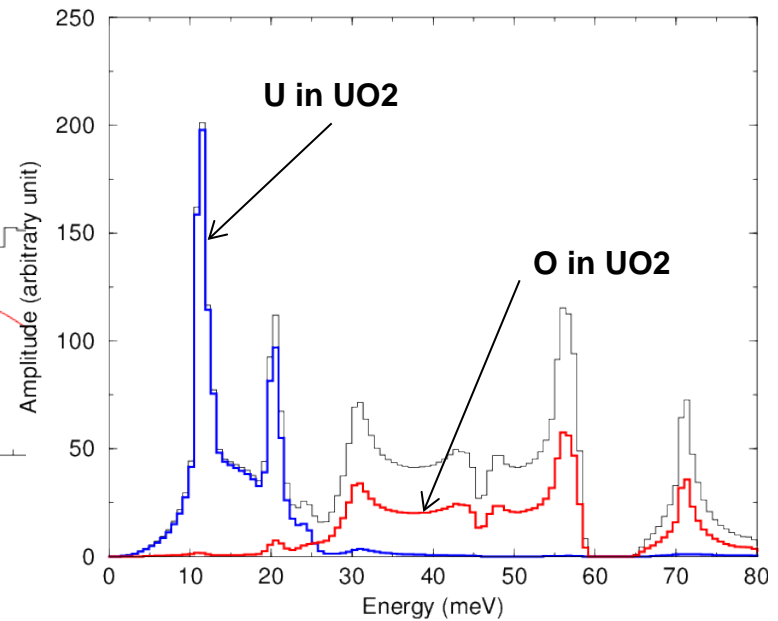
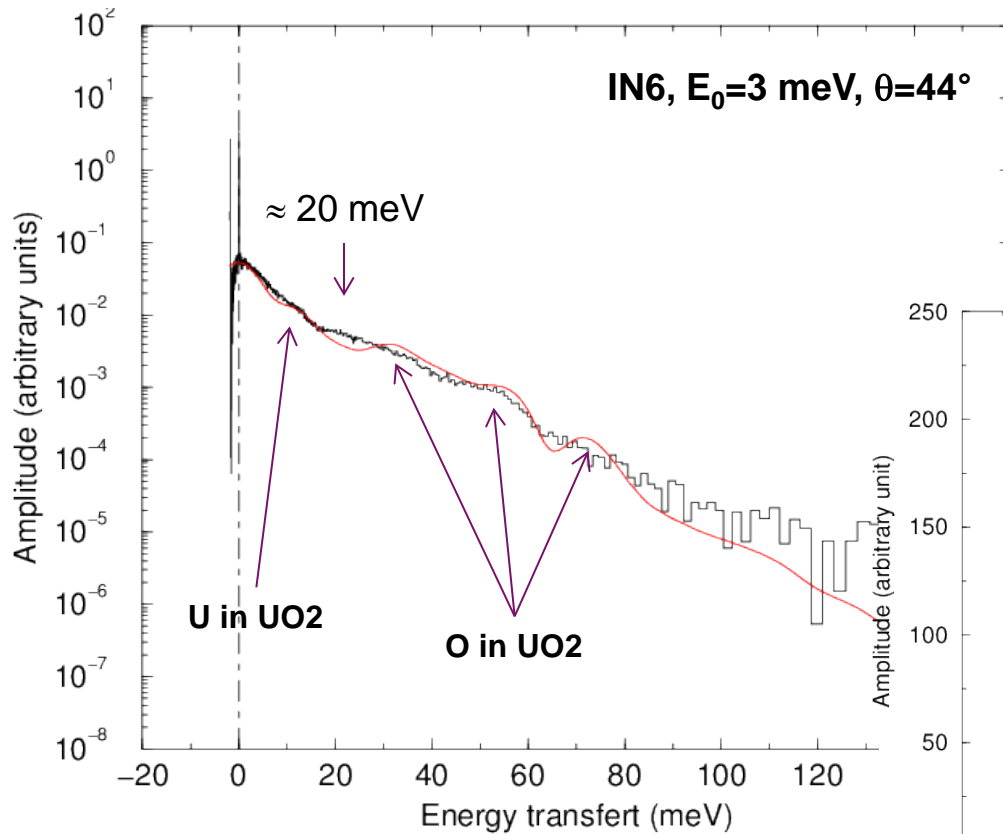

Comparison with data from J. Pang (Phys. Rev. B89, 115132, 2014)

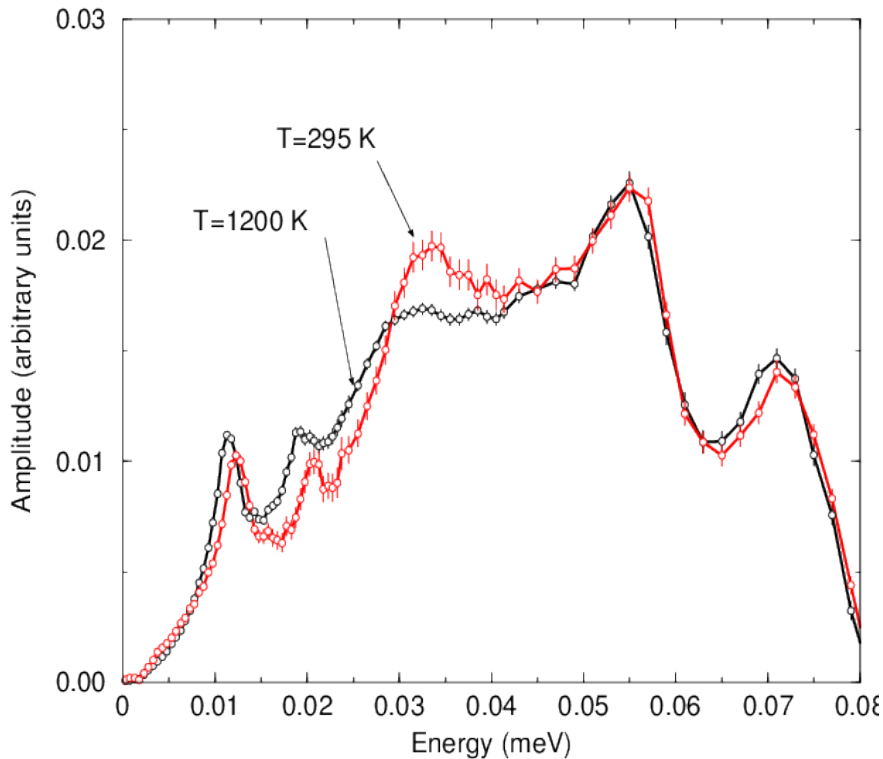

Neutron-weighted phonon density of states of UO2 (J. Pang)

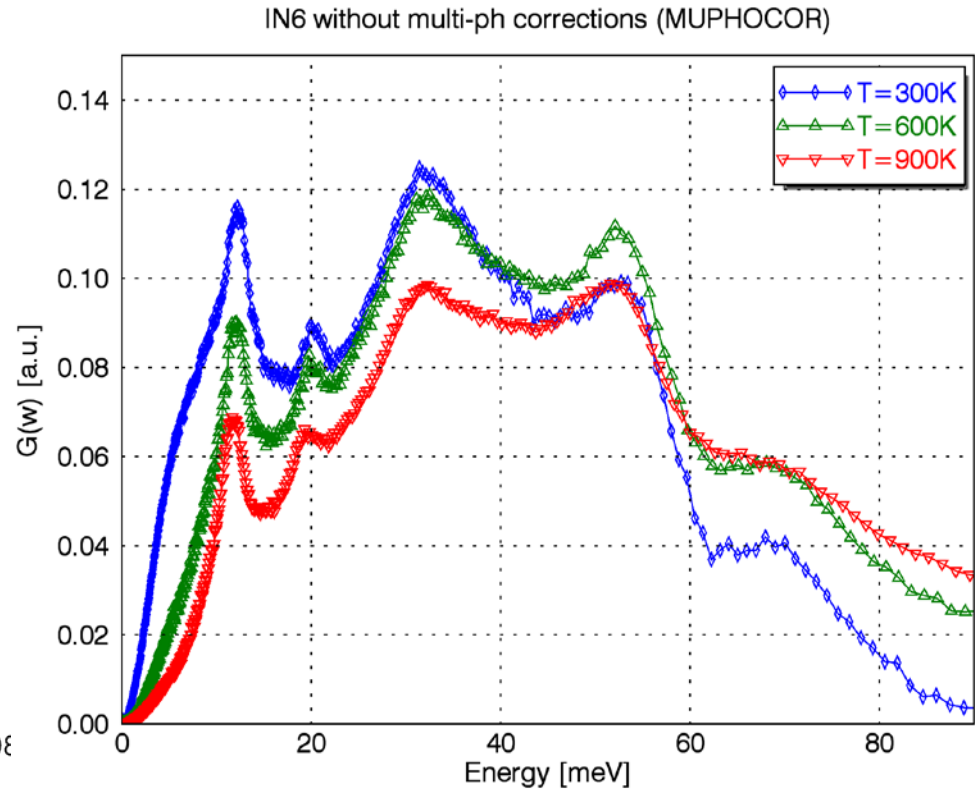

Density of states of UO2 extracted from the IN6 data by J. Ollivier, ILL

Measurement of the double-differential neutron cross section of U in UO₂ up to 2000 K

- Main problem \Rightarrow sealed tubes are needed
- Strong efforts from JRC-Karlsruhe (**R. Caciuffo**) and ILL (**A. Filhol**) to find a solution \Rightarrow laser welding (Nb or Mo tubes)



Any suggestions are welcome !

INTEGRAAL @GELINA for inelastic scattering validation

JEF/DOC-1824

From EXCALIBUR

Experiment in CALIBAN on Uranium 238



to INTEGRAAL

Integral Transmission Experiment
in Gelina Relying on Activation Analysis



CEA/DEN/DER/SPRC/LEPh

CEA/DEN/DER/SPEX/LPE

JRC GEEL

Pierre Leconte, David Bernard, Pascal Archier

Benoit Geslot

Arjan Plompen, Markus Nyman, Francesca Belloni

JEFF - NEEDS Workshop, OECD Conference Center, April 24-25, 2017.

THE INTEGRAAL EXPERIMENT IN GELINA

Ingredients for the experiment

- Starting point: use of different disks of depleted U available at JRC Geel to build a slab of thickness $\sim 15 \text{ cm} \times 20 \text{ cm} \varnothing$

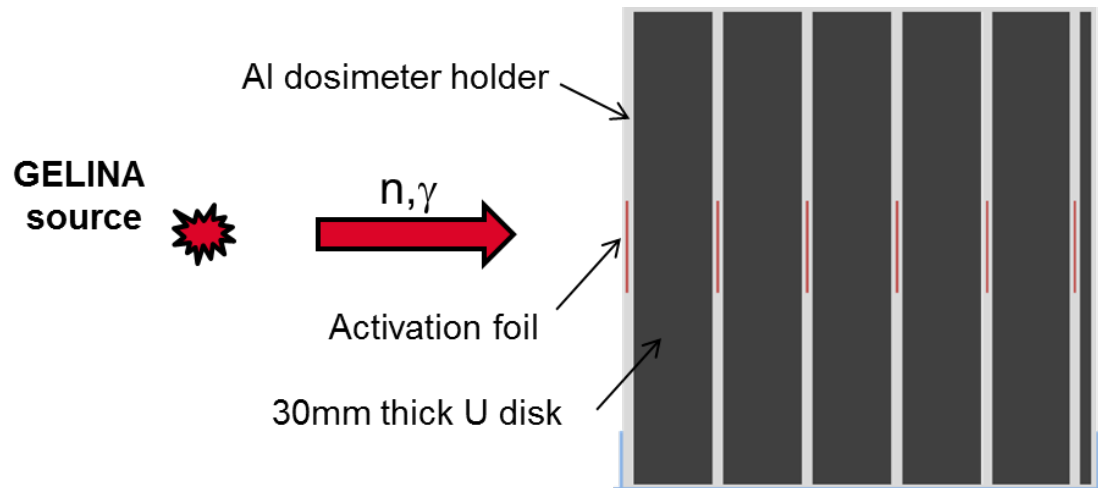

- Use of various dosimeters with energy thresholds ranging from thermal to 9 MeV
- Measurement of the integral transmission coefficient:

$$\bar{T}(x) = R(x) / R(0)$$

$\Rightarrow R(x)$ = microscopic activation rate on the dosimeter placed behind a Uranium thickness of x

Dosimeter	Threshold reaction	E50%
Au	$^{197}\text{Au}(n, \gamma)^{198}\text{Au}$	Thermal
Ni	$^{58}\text{Ni}(n, p)^{58}(\text{g}+\text{m})\text{Co}$	4.20
Fe	$^{54}\text{Fe}(n, p)^{54}\text{Mn}$	4.28
	$^{56}\text{Fe}(n, p)^{56}\text{Mn}$	7.58
	$^{56}\text{Fe}(n, \gamma)^{59}\text{Fe}$	Thermal
Rh	$^{103}\text{Rh}(n, n'\text{g})^{103\text{m}}\text{Rh}$	2.38
Co	$^{59}\text{Co}(n, p)^{59}\text{Fe}$	5.76
	$^{59}\text{Co}(n, \gamma)^{60}\text{Co}$	Thermal
Al	$^{59}\text{Co}(n, p)^{56}\text{Mn}$	8.36
	$^{27}\text{Al}(n, a)^{24}\text{Na}$	8.66
Mg	$^{24}\text{Mg}(n, p)^{24}\text{Na}$	8.26
Ti	$^{46}\text{Ti}(n, p)^{46}\text{Sc}$	6.08
	$^{47}\text{Ti}(n, p)^{47}\text{Sc}$	3.82
	$^{48}\text{Ti}(n, p)^{48}\text{Sc}$	8.35
In	$^{115}\text{In}(n, n'\text{g})^{115\text{m}}\text{In}$	2.67
U	$^{238}\text{U}(n, f)\text{PF}$	2.78

THE INTEGRAAL EXPERIMENT IN GELINA

Individual uranium disks (~20kg each)



■ Sensitivity study of the integral transmission rate $T(x)$ to microscopic cross sections

- Linear increase with ^{238}U thickness up to 12cm
- Worse at 15cm due to room return effect

Threshold reaction	E50%	x (cm)	Integral transmission coefficient $T(x)$	
			Geometry with concrete walls	Geometry without concrete walls
$^{115}\text{In}(n,n')$	2.7	3	0.620 ± 0.017	0.645 ± 0.005
		6	0.350 ± 0.011	0.351 ± 0.003
		9	0.192 ± 0.017	0.184 ± 0.002
		12	0.105 ± 0.015	0.091 ± 0.001
		15	0.073 ± 0.004	0.043 ± 0.001
$^{54}\text{Fe}(n,p)$	4.3	3	0.600 ± 0.025	0.631 ± 0.008
		6	0.339 ± 0.016	0.355 ± 0.005
		9	0.196 ± 0.012	0.192 ± 0.003
		12	0.105 ± 0.008	0.102 ± 0.002
		15	0.063 ± 0.006	0.052 ± 0.002
$^{24}\text{Mg}(n,p)$	8.3	3	0.617 ± 0.051	0.629 ± 0.051
		6	0.338 ± 0.031	0.383 ± 0.058
		9	0.213 ± 0.029	0.211 ± 0.033
		12	0.115 ± 0.018	0.123 ± 0.063
		15	0.051 ± 0.011	0.070 ± 0.006

Threshold reaction	E50%	x (cm)	$S(\sigma_i, \Delta x)$		
			Elastic scattering	Total inelastic	Fission
$^{115}\text{In}(n,n')$	2.7	3	0.03	-0.36	-0.09
		6	-0.04	-0.77	-0.16
		9	-0.16	-1.13	-0.25
		12	-0.26	-1.39	-0.30
		15	-0.42	-0.99	-0.21
$^{54}\text{Fe}(n,p)$	4.3	3	-0.03	-0.29	-0.11
		6	-0.08	-0.63	-0.21
		9	-0.14	-0.97	-0.34
		12	-0.25	-1.24	-0.41
		15	-0.45	-1.11	-0.34
$^{24}\text{Mg}(n,p)$	8.3	3	-0.11	-0.07	-0.16
		6	-0.22	-0.26	-0.29
		9	-0.09	-0.38	-0.49
		12	-0.20	-0.56	-0.57
		15	-0.38	-0.66	-0.65

■ A tricky issue: the room return effect

⇒ Only significant for low threshold reactions and deep penetrations

⇒ More information in: P. Leconte, C. De Saint Jean, B. Geslot, A. Plompen, F. Belloni, M. Nyman, On the feasibility to perform integral transmission experiments in the GELINA target hall at IRMM, Proc of the ICRS13-RPSD2016 Conference.

THE INTEGRAAL EXPERIMENT IN GELINA

Ready for neutrons



Any good experiment has some tape !

Integral Transmission Rate $T(x)$ – threshold neutron reactions

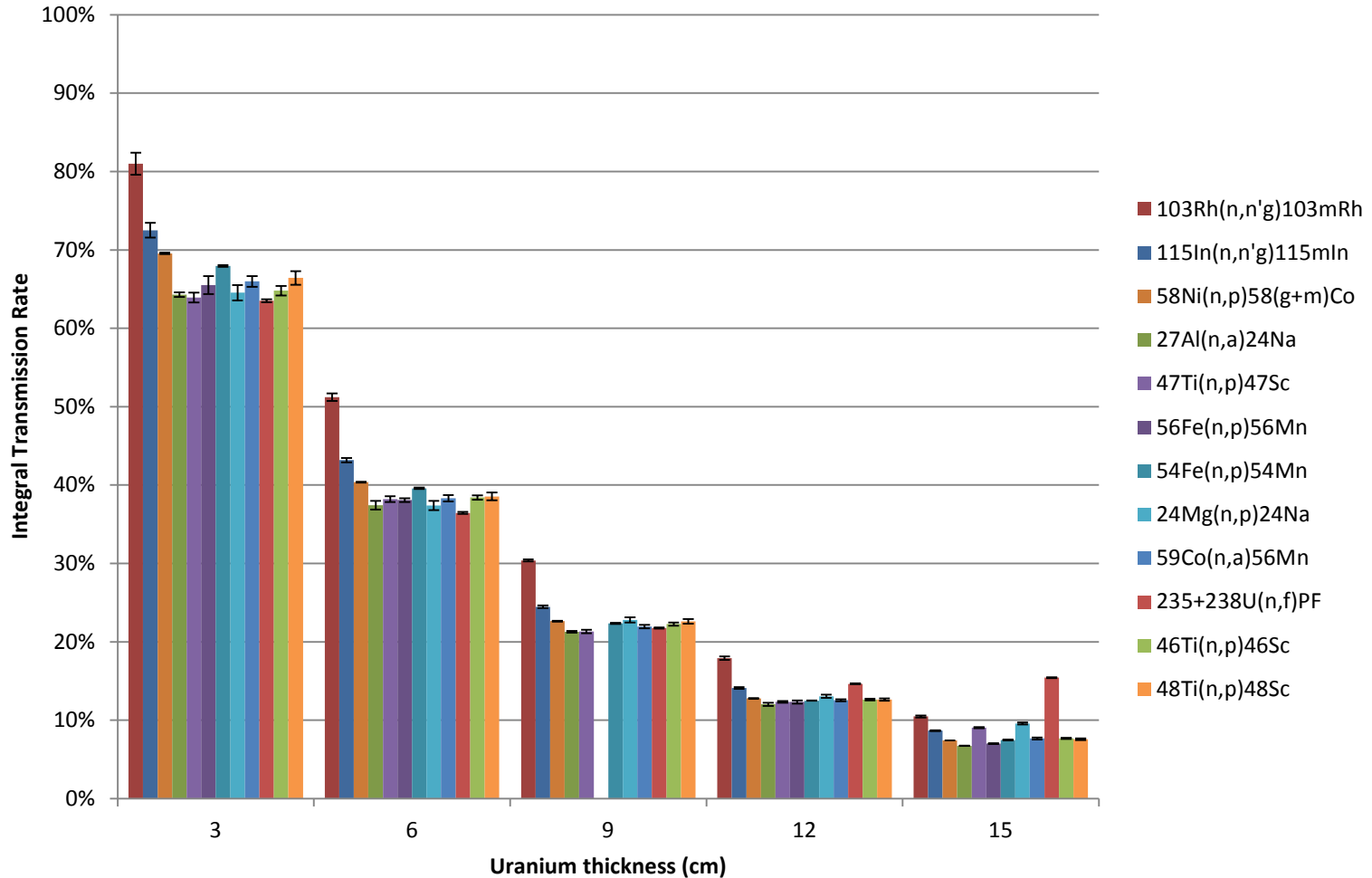

- **The GELINA facility has the potential to provide new high quality integral transmission experiments for ND improvements**
- **First tests realized in GELINA have shown promising results for ^{238}U**
- **The Monte-Carlo analysis is going to start next months so... suspense!**

DE LA RECHERCHE À L'INDUSTRIE

cea

www.cea.fr



The CANDELLE project

Neutron calibration of lithium-enriched thermo-luminescent dosimeters @ PEREN for gamma-heating measurements

CEA, DEN/CAD/DER/SPEX
LPSC, UGA, CNRS/IN2P3

DE LA RECHERCHE À L'INDUSTRIE

cea

www.cea.fr



ZEPHYR

Zero-power **E**xperimental
Physics **R**eactor –
A new critical facility @ CEA
Cadarache

Project status and associated R&D

CEA, DEN/CAD/DER/SPE_x



SPECTRAL Project

Spectrométrie Neutronique Rapide Large Bande JEF/DOC-1821

L. Dioni¹, R. Jacqmin², V. Gressier³, P. Leconte², B. Perot⁴,
C. Carasco⁴, V. Lacoste³, M. Aiche⁵, L. Mathieu⁵, B. Stout¹

¹Institut Fresnel (Aix-Marseille Université), ²CEA-CAD/DER,
³IRSN-CAD, ⁴CEA-CAD/DTN, ⁵CENBG Bordeaux

JEFF/NEEDS
Paris, 24-25/04/2017

Summary

- ▶ SPECTRAL project: develop a neutron spectrometer system based on a combination of measurement techniques for the spectral characterization of intermediate-to-fast energy neutron spectra (together with gammas)
- ▶ Main initial motivation = new measurements + extended use of MASURCA after the current refurbishment work
- ▶ Project has triggered interest among various groups and for different applications
- ▶ Organic scintillators are good candidates for the measurement of the neutron spectrum above about 1 MeV
- ▶ Solution-grown stilbene has a wider energy domain but lacks experimental data, need for a full characterization of the detector response
- ▶ The SPECTRAL plans in 2017 are to test the stilbene in various neutron fields

FALSTAFF@SPIRAL2/NFS



FALSTAFF SPECTROMETER

Status of development

L. Thulliez, A. Chietera, E. Berthoumieux, D. Doré, A. Letourneau
Irfu/DPhN

Ph. Legou, M. Combet, M. Kebbiri, A. Marcel
Irfu/SEDI

J. Pancin, X. Ledoux, M.O. Frégeau
Ganil, Caen

F.-R. Lecolley
LPC Caen

In collaboration with S. Oberstedt (IRMM)

FALSTAFF experimental setup

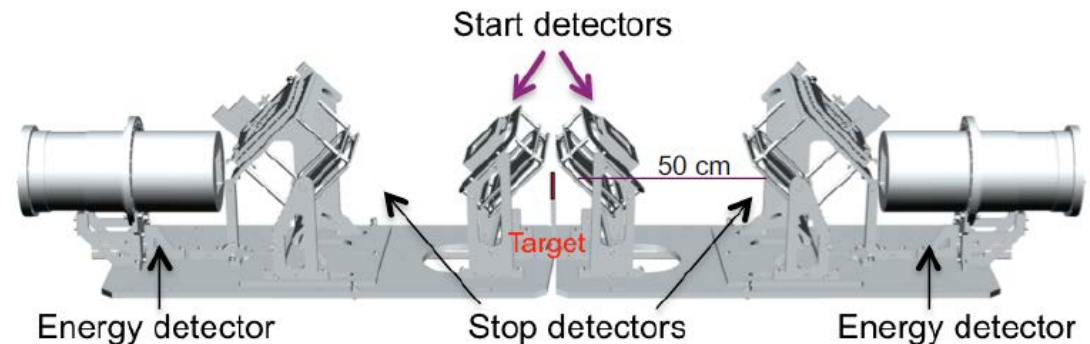

DE LA RECHERCHE À L'INDUSTRIE

cea



Other fundings



CEA/DEN, P2IO

www.cea.fr

On-going activities



Voltage on the anode to increase the field

Tests of new SED-MWPC detectors

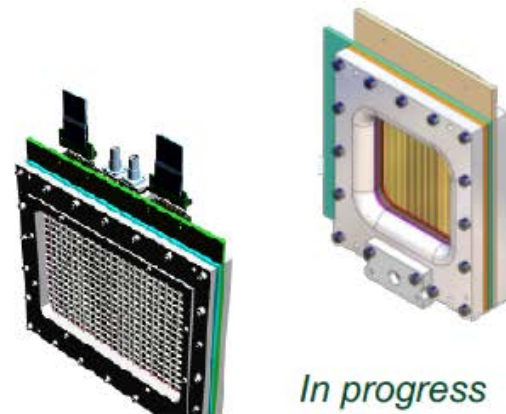

In progress



New Acquisition system for position signals



Equipment of the new reaction chamber



EXPERIMENTAL PROGRAMME ON NUCLEAR DATA AT ILL :

From Lohengrin to FIPPS spectrometers

FY Collaboration :

Kessedjian G.¹, Julien-Laferrriere S.^{1,2}, Chebboubi A.^{1,2}, Serot O.², Sage C.¹, Méplan O.¹, Bernard D.², Litaize O.², Blanc A.³, Faust H.³, Mutti P.³, Köster U.³, Letourneau A.⁴, Materna T.⁴, Rapala M.⁴

FIPPS collaboration :

G. Kessedjian¹, A. Blanc³, A. Chebboubi^{1,2}, H. Faust³, E. Froidefond¹, M. Jentschel³, U. Köster³, C. Michelagnoli³, P. Mutti³, E. Ruiz-Martinez³, G. Simpson¹

- 1 LPSC, Université Grenoble-Alpes, CNRS/IN2P3, F-38026 Grenoble Cedex, France
- 2 CEA, DEN, DER, SPRC, LEPh, Cadarache center, F-13108 Saint Paul lez Durance, France
- 3 Institut Laue-Langevin, F-38042 Grenoble Cedex 9, France
- 4 CEA, DSM, IRFU, SPhN, LEARN, Saclay center, F-91191 Gif-sur-Yvette, France

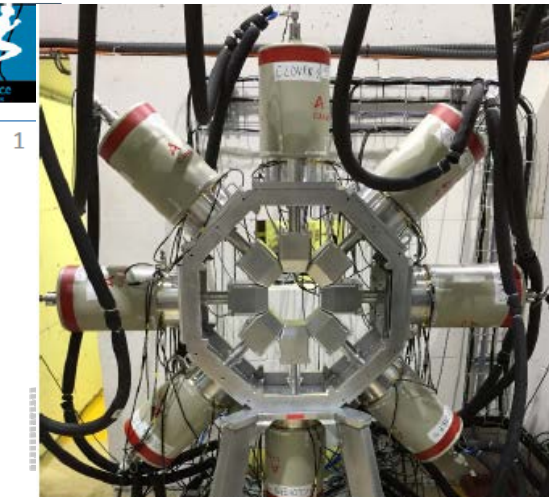
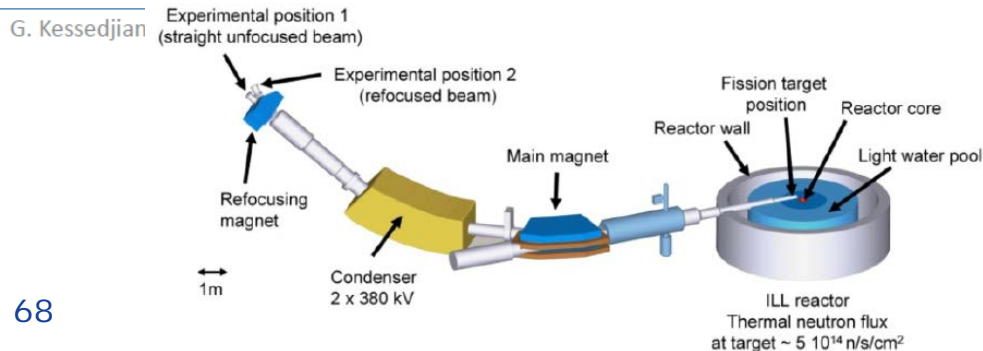

Recent results and perspectives using PPACs for fission measurements

L. Audouin, D. Ramos, Y. Chen, C. Le Naour
IPN Orsay
L. Tassan-Got
CERN

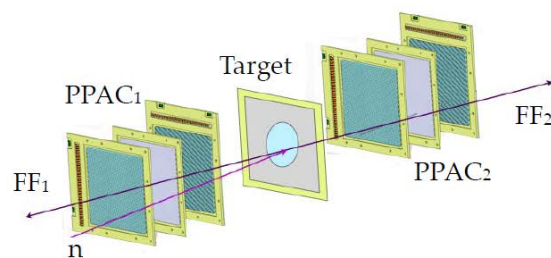

Parallel Plate Avalanche Counters:
2 segmented cathodes + 1 anode
3 mm gap, 5 mbar C₃F₈
20x20 cm² active area

- FF-detection in coincidence → α-background rejection
- FF-position measurement → Fission point tracking
- Compact & transparent configuration → 9-targets setup
- 10 ns FWHM time-response → E_n up to 1 GeV (EAR-1)

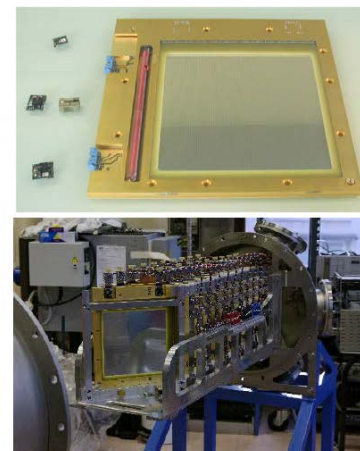

JEFF-NEEDS joint workshop - 24/04/2017



Emitting point on the target

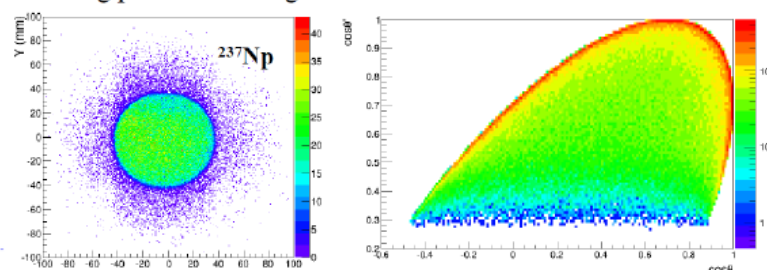

Measurements relevant for JEFF from experiments with the LICORNE neutron source

JEF/DOC-1815



J.N. Wilson, M. Lebois and L. Qi

IPN Orsay

J. Taieb et al, Nuclear Instruments and Methods in Physics Research A 833 (2016) 1-7

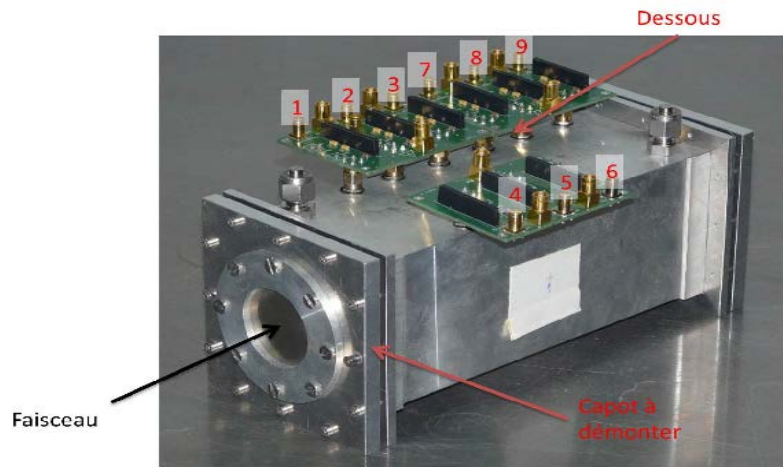

- Good alpha-fission fragment discrimination: <2%
- Good Time resolution: <1ns
- Efficiency: ~100%
- 360mg ^{238}U in 72 deposits

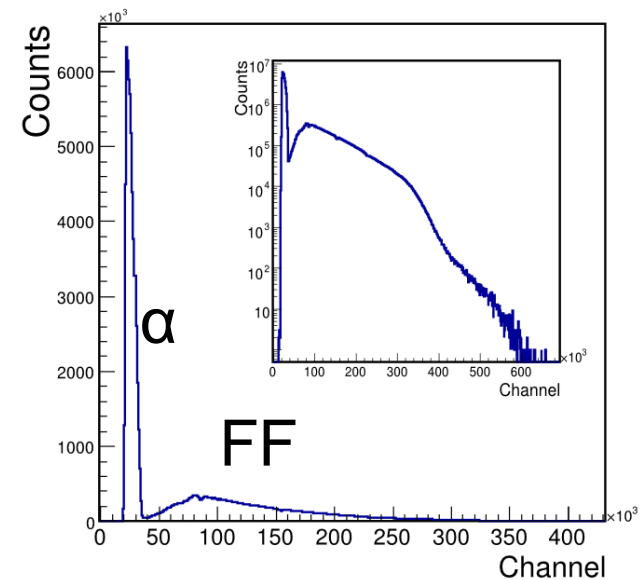
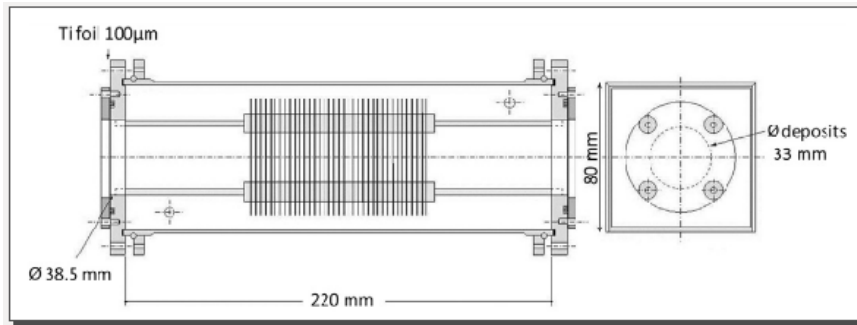

**Fission- alpha
discrimination**

Measured Spectrum: $g(x)$

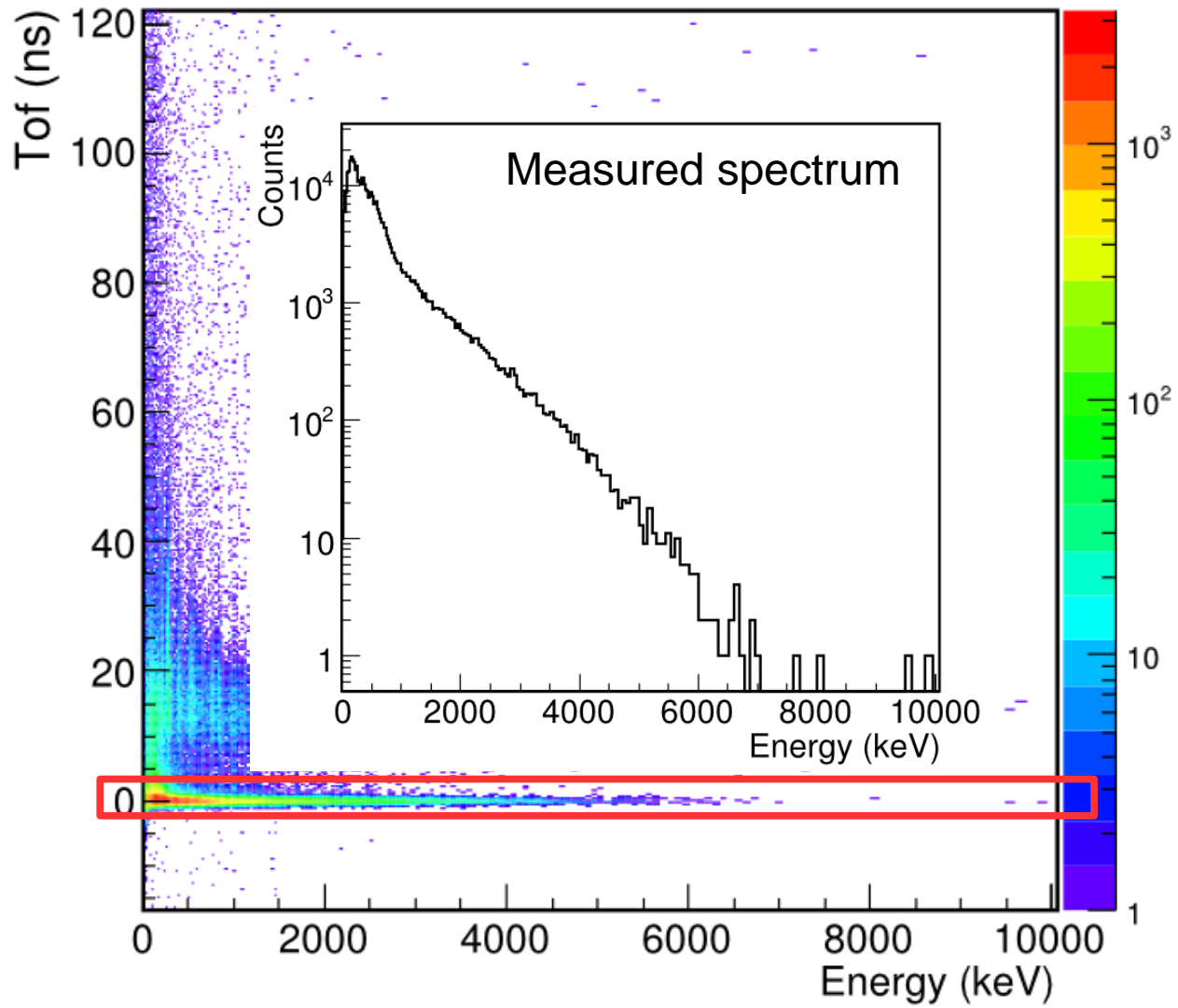

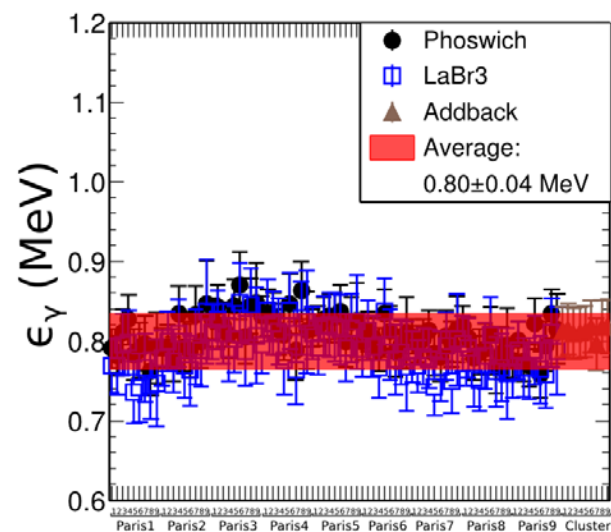
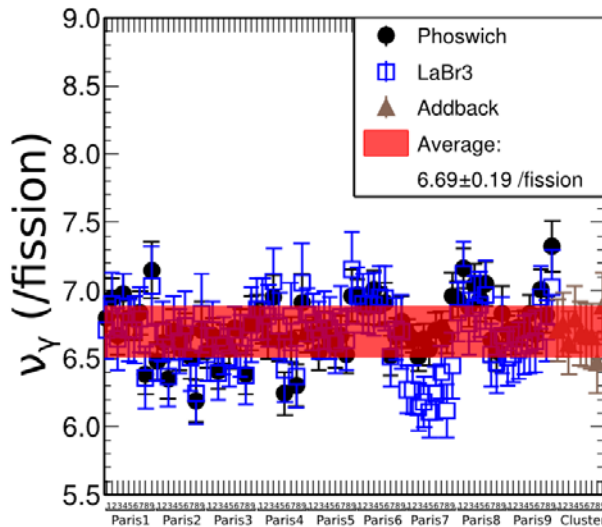
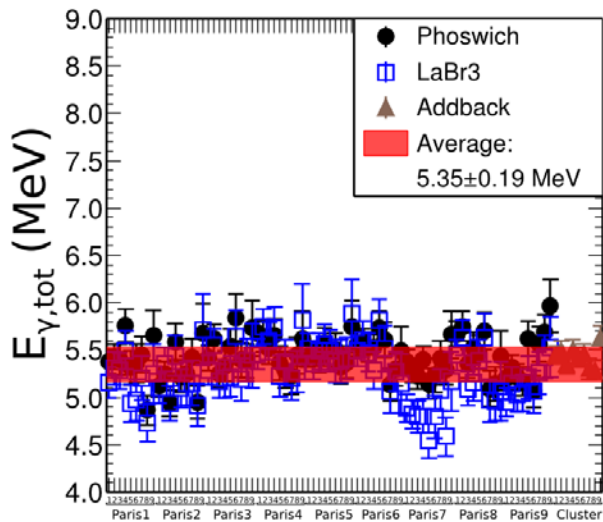
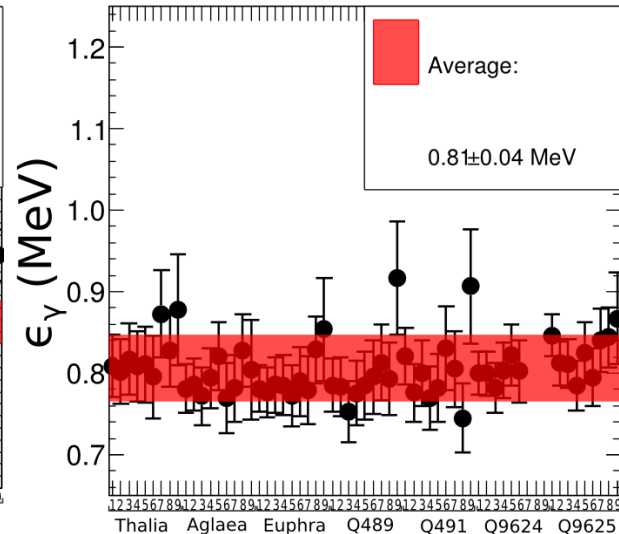
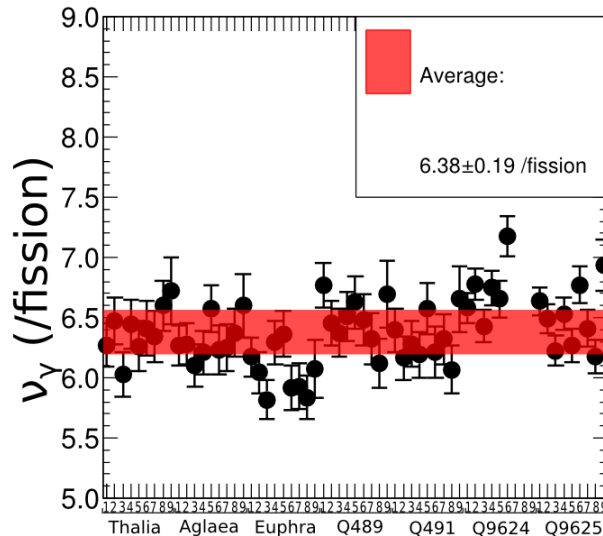
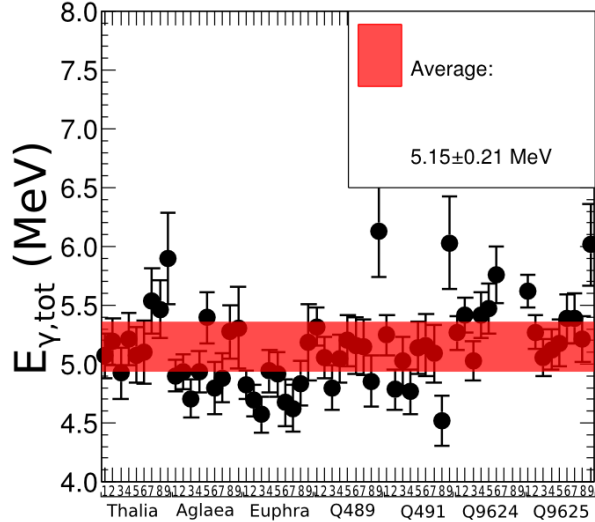

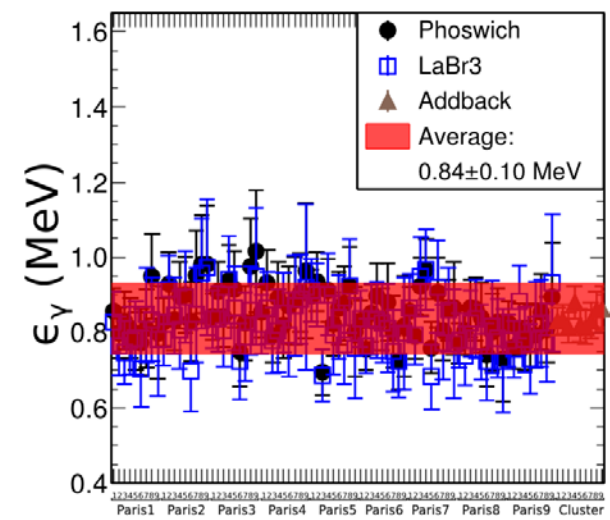
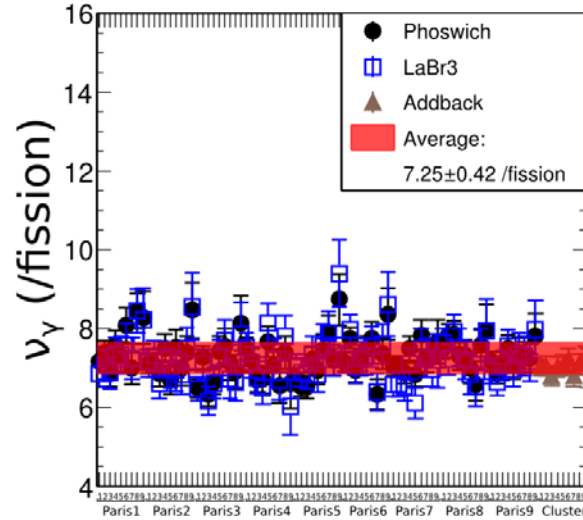
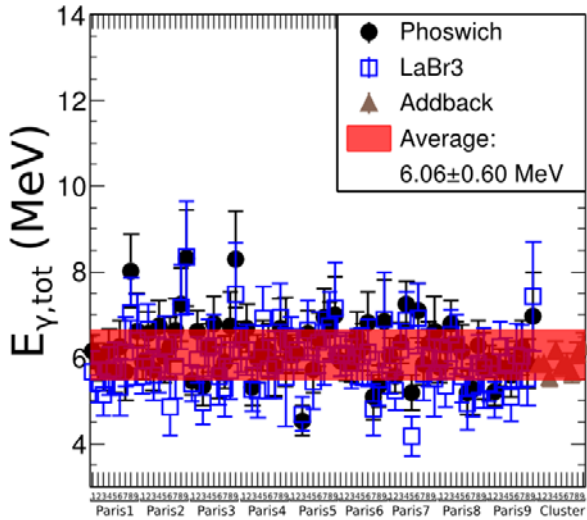
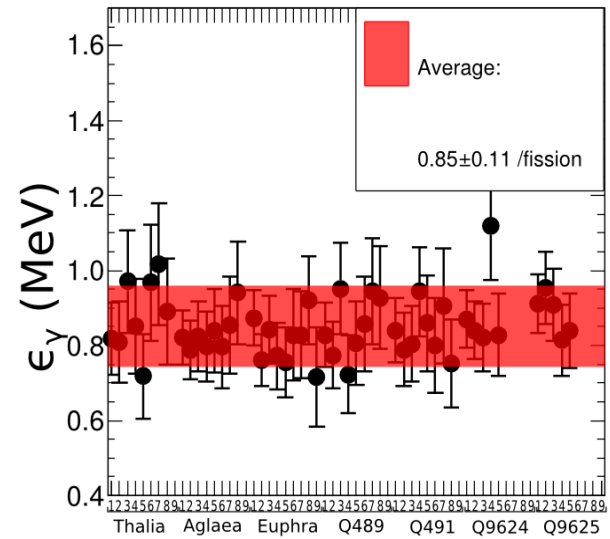
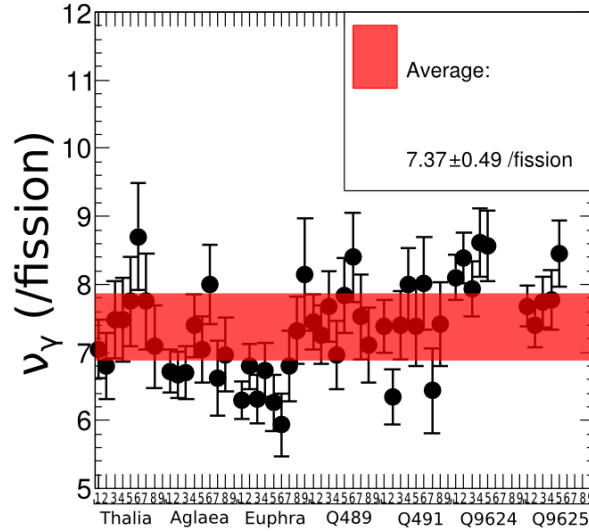
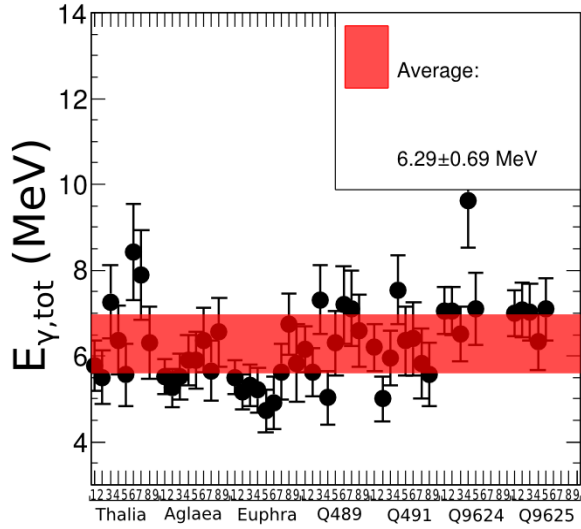

Total absorption measurements for reactor applications (Algora et al.)

Goal: to obtain beta decay data free from the Pandemonium effect that can improve the predictions for the decay heat and the neutrino spectrum from reactors

Technique: total absorption spectroscopy

Experiments: performed at IGISOL (Jyväskylä), that provides radioactive beams of very high isotopic purity (trap assisted experiments)

Spokespersons: A. Algora, J. L. Tain, M. Fallot

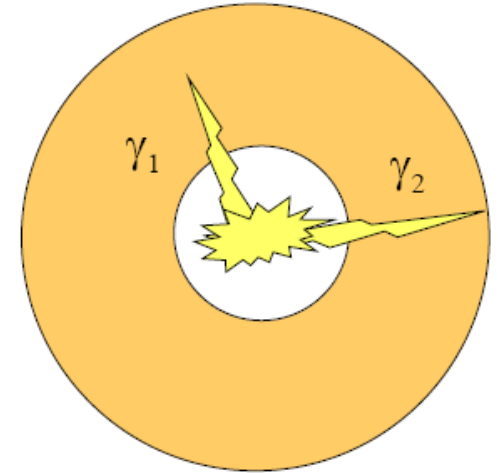

$$d = R(B) \cdot f$$

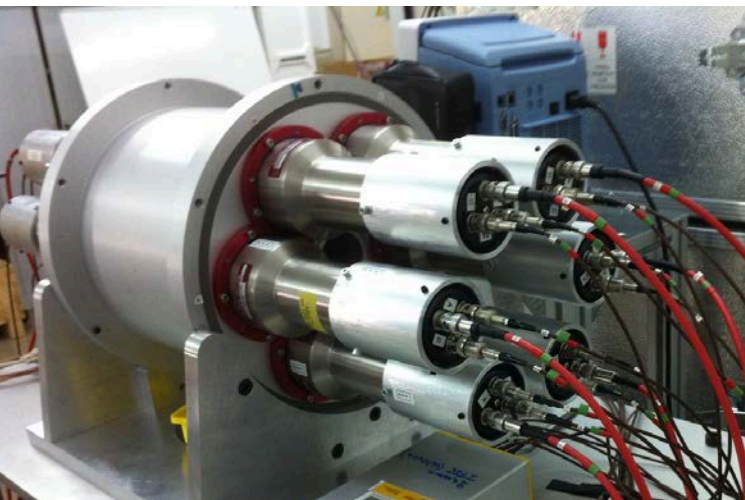

“Recently” performed measurements

VTAS run (November 2009)

Measurement of beta delayed neutron emitters cases of high priority for decay heat. The idea was to measure the same nuclides using different techniques and different setups (TAS, Pn, neutron spectrum meas.). In this run we also measured some cases of interest for neutrino physics. All analyses finished, some results are already published and the rest in preparation for publication. BaF2 TAS detector

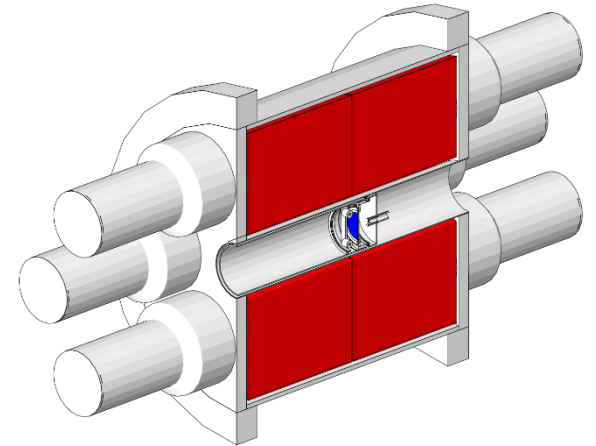

DTAS run (December 2014)

Primary goal: measurement of nuclei of high interest for the prediction of the neutrino spectrum in reactors. Priority list defined by the Nantes group. NaI detector DTAS developed for DESPEC (FAIR).

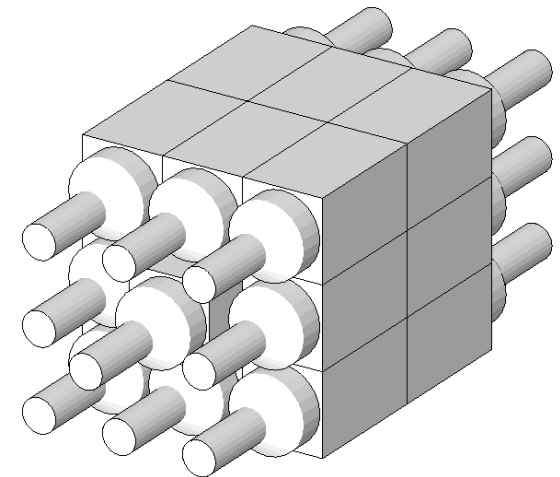

Why JYFL: IGISOL + a bonus

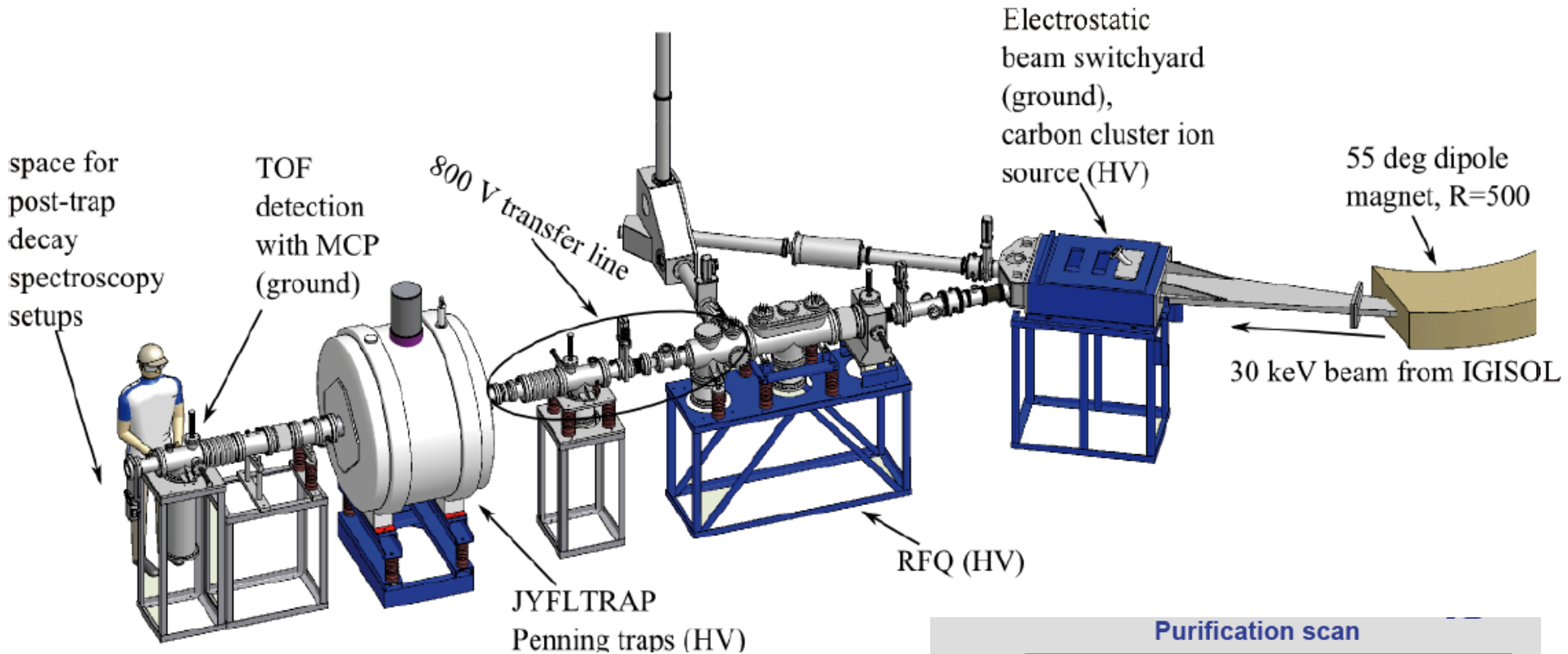

The main reasons are the chemical insensitivity (ion guide technique), high purity by means of purification of the beam using the JYFLTRAP and acceptable yields!

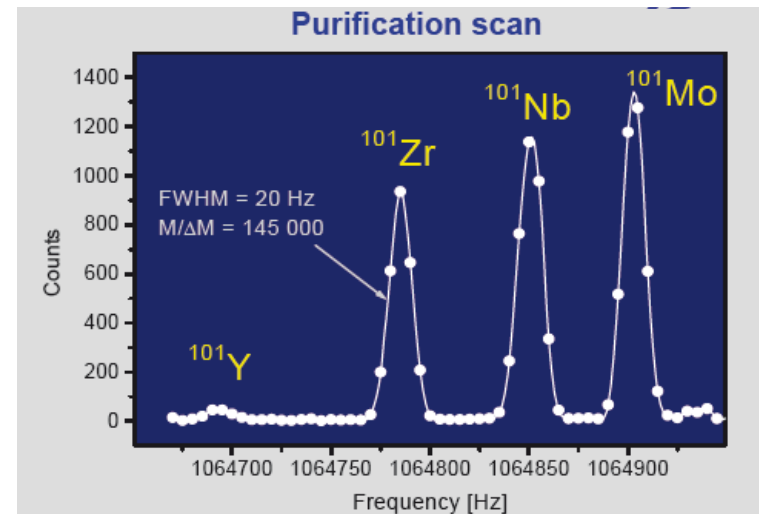

Beta delayed neutron emitters, example: ^{87}Br

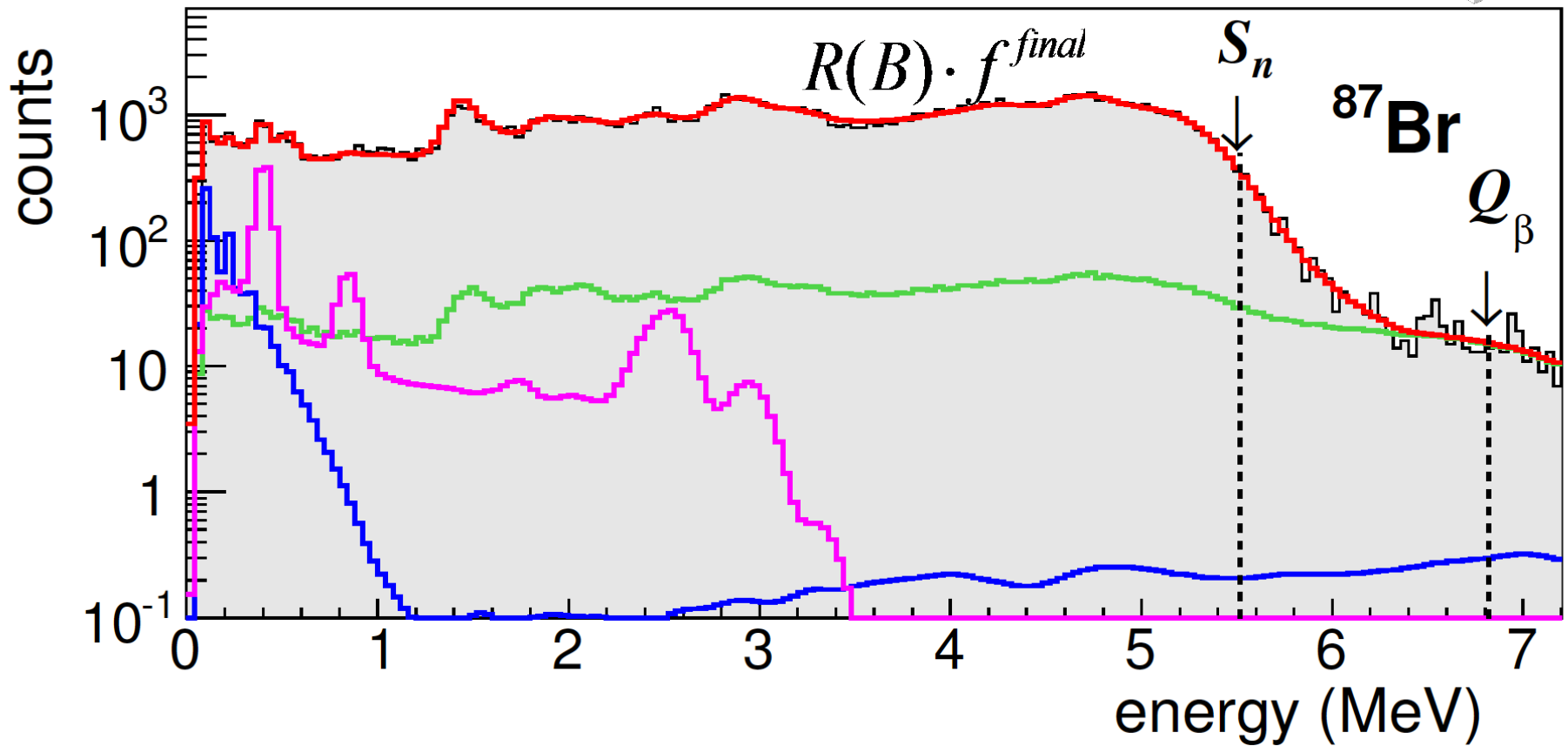
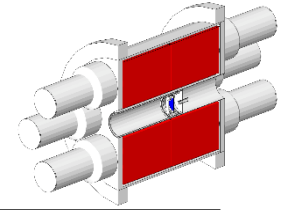

E. Valencia, et al, PRC 95, 024320 (2017)

J. L. Tain et al., PRL 115, 062502

Beta delayed neutron emitters, example: ^{88}Br

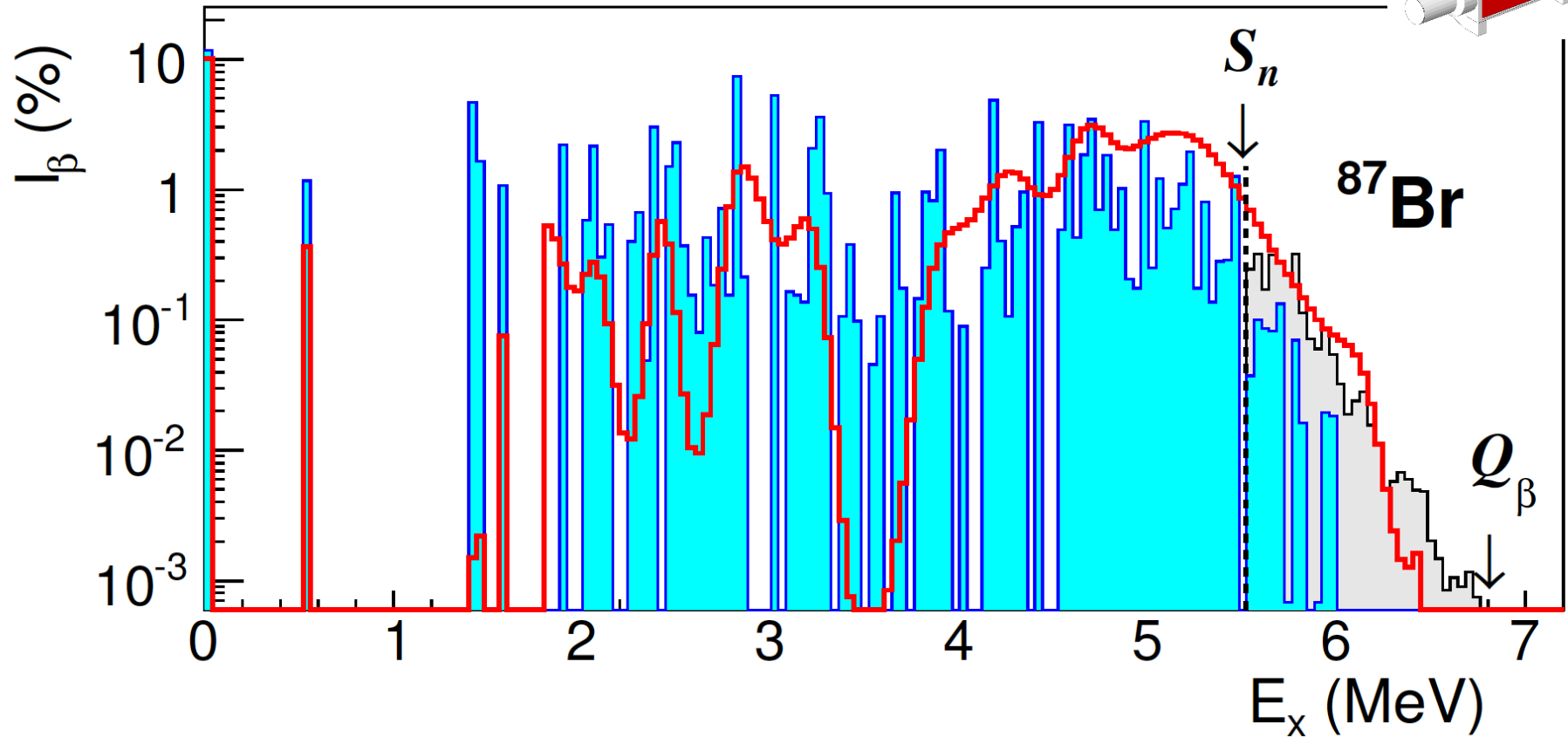
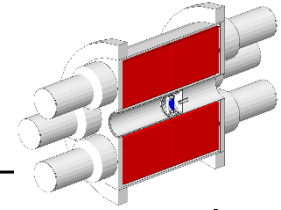

E. Valencia, et al., PRC 95, 024320 (2017)

J. .L. Tain et al., PRL 115, 062502

Impact of the studied (bdn) cases

E. Valencia, JL Tain, A. Algora et al, PRC 95, 024320 (2017)

Isotope	\bar{E}_γ (keV)		\bar{E}_β (keV)	
	ENSDF	TAGS	ENSDF	TAGS
^{87}Br	3009	3938^{+40}_{-67}	1599	1159^{+32}_{-19}
^{88}Br	2892	4609^{+78}_{-67}	2491	1665^{+32}_{-38}
^{94}Rb	1729	4063^{+62}_{-66}	2019	2329^{+32}_{-30}

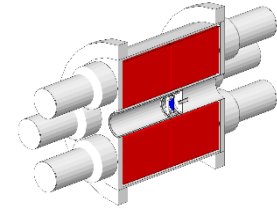

Isotope	\bar{E}_β (keV)	
	This work	Ref. [58]
^{87}Br	1170^{+32}_{-19}	1410 ± 10
^{88}Br	1706^{+32}_{-38}	1680 ± 10
^{94}Rb	2450^{+32}_{-30}	2830 ± 70

Isotope	P_γ (%)	P_n (%)
^{87}Br	3.50^{+49}_{-40}	2.60(4)
^{88}Br	1.59^{+27}_{-22}	6.4(6)
^{94}Rb	0.53^{+33}_{-22}	10.18(24)

Astrophysics implications discussed in
Tain et al. PRL 115, 062502

Impact of ^{91}Rb case

^{91}Rb

	\bar{E}_γ [keV]	\bar{E}_β [keV]
Present result	2787(29)	1330(22)
Greenwood et al.	2885.2 ^a	1282.0 ^a
ENDF/B-VI.8	2340(140)	1561(25)
JEFF-3.1.1	2706(27)	1368(13)
JENDL/FPD-2011	2340(50)	1610(190)
Rudstam et al.	2335(33)	1560(30)

^a No error evaluation was performed

^{91}Rb is a particular case. It was used as a normalization point in Rudstam measurements of the mean gamma energies assuming that it does not suffer from Pandemonium. We showed (in agreement with earlier measurements by Greenwood, that it suffered from Pandemonium. So Rudstam mean gamma energies data require re-normalization.

Greenwood vs Rudstam (orig. pointed out by O. Bersillon)

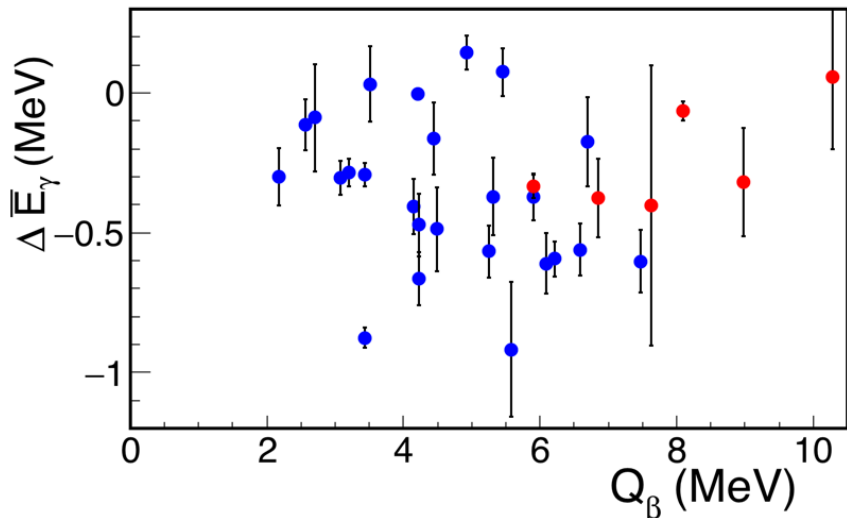

There are systematic differences between the mean gamma energies obtained by Rudstam and Greenwood (for the cases measured by both, in red our new TAS data compared with Rudstam). Mean value of the differences -360 keV.

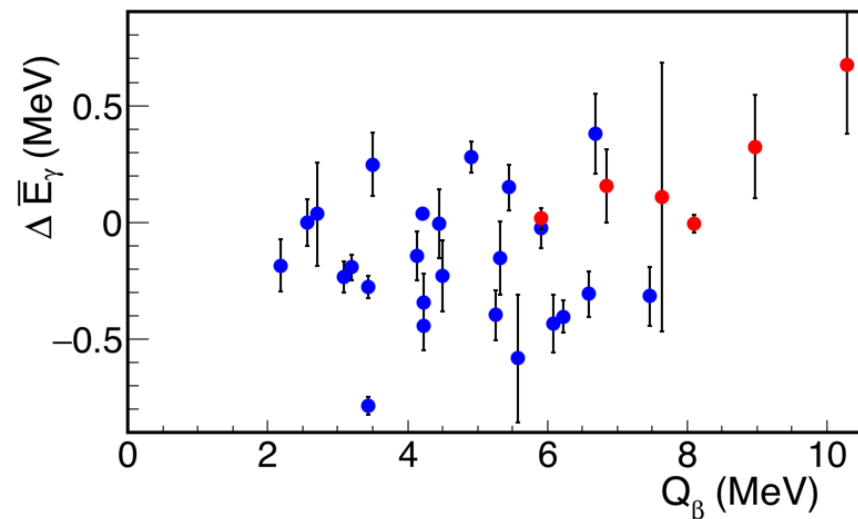

The mean value of the differences is reduced after the renormalization of Rudstam data induced by our new measurement of the decay of ^{91}Rb . The discrepancy between the two data sets does not disappear completely. (new mean value -180 keV).

92Rb: star case, nuclear data matters

TABLE I. Main contributors to a standard PWR antineutrino energy spectrum computed with the MURE code coupled with the list of nuclear data given in Ref. [12], assuming that they have been emitted by ^{235}U (52%), ^{239}Pu (33%), ^{241}Pu (6%), and ^{238}U (8.7%) for a 450 day irradiation time and using the summation method described in Ref. [12].

	4–5 MeV	5–6 MeV	6–7 MeV	7–8 MeV
^{92}Rb	4.74%	11.49%	24.27%	37.98%
^{96}Y	5.56%	10.75%	14.10%	...
^{142}Cs	3.35%	6.02%	7.93%	3.52%
^{100}Nb	5.52%	6.03%
^{93}Rb	2.34%	4.17%	6.78%	4.21%
^{98m}Y	2.43%	3.16%	4.57%	4.95%
^{135}Te	4.01%	3.58%
^{104m}Nb	0.72%	1.82%	4.15%	7.76%
^{90}Rb	1.90%	2.59%	1.40%	...
^{95}Sr	2.65%	2.96%
^{94}Rb	1.32%	2.06%	2.84%	3.96%

Gs to gs feeding
Evolution

94(+6–20)(<2000)
Olson et al.
51(18) % (<2012)
NDS 2000
95.2(7) % (2012)
NDS 2012
G. Lhersonneau
(PRC74 (2006)017308)
New experiment ????

Table from
Zakari-Issoufou et al.
PRL 115.102503(2015)

92Rb: star case

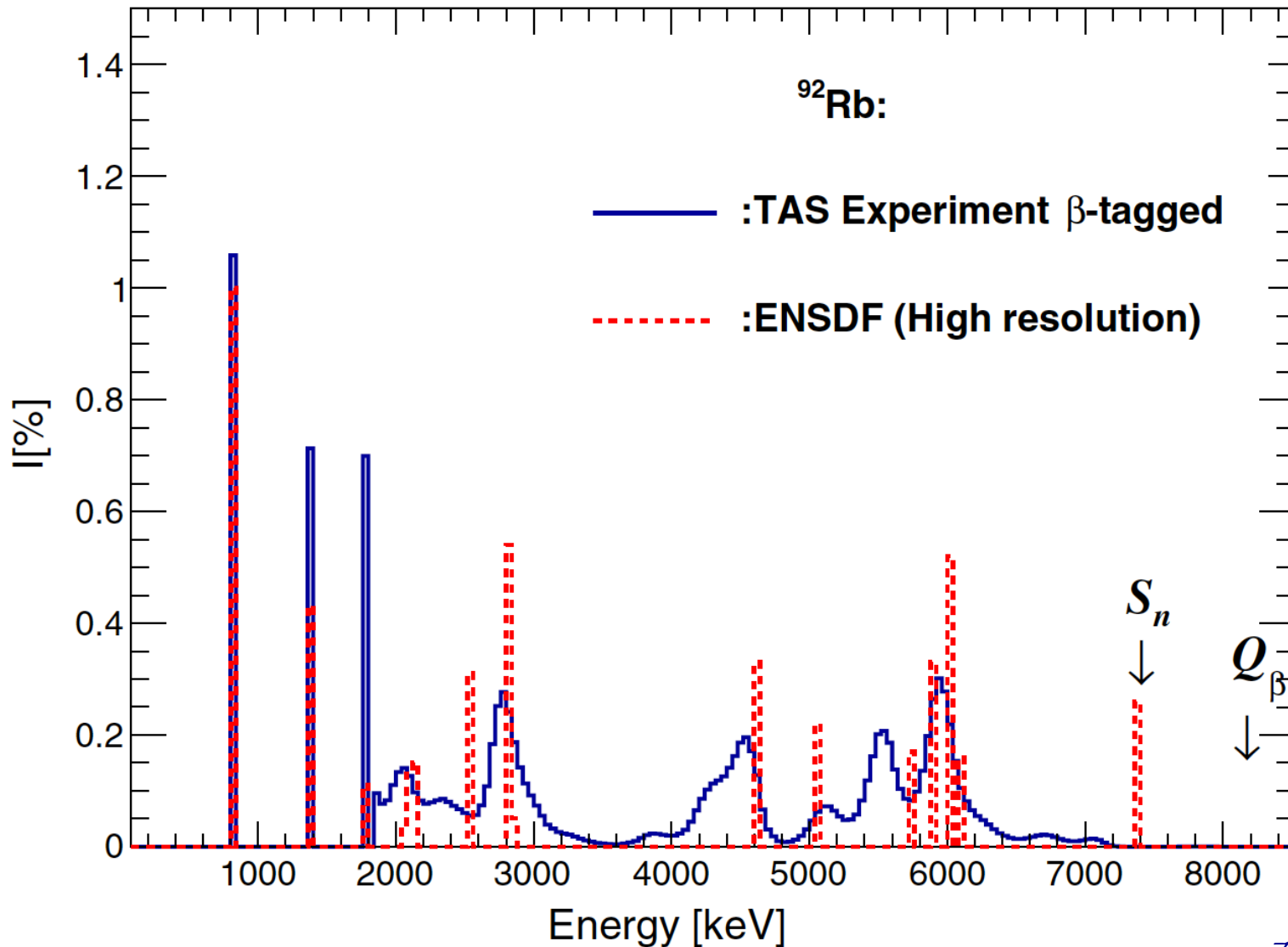

Gs to gs feeding
Evolution

94(+6-20) (<2000)

Olson et al.

51(18) % (<2012)

NDS 2000

95.2(7) % (2012)

NDS 2012

G. Lhersonneau

(PRC74 (2006)017308)

87.5(2.5)% (2015)

TAS result

Zakari-Issoufou et al.
PRL 115.102503(2015)

92Rb: star case

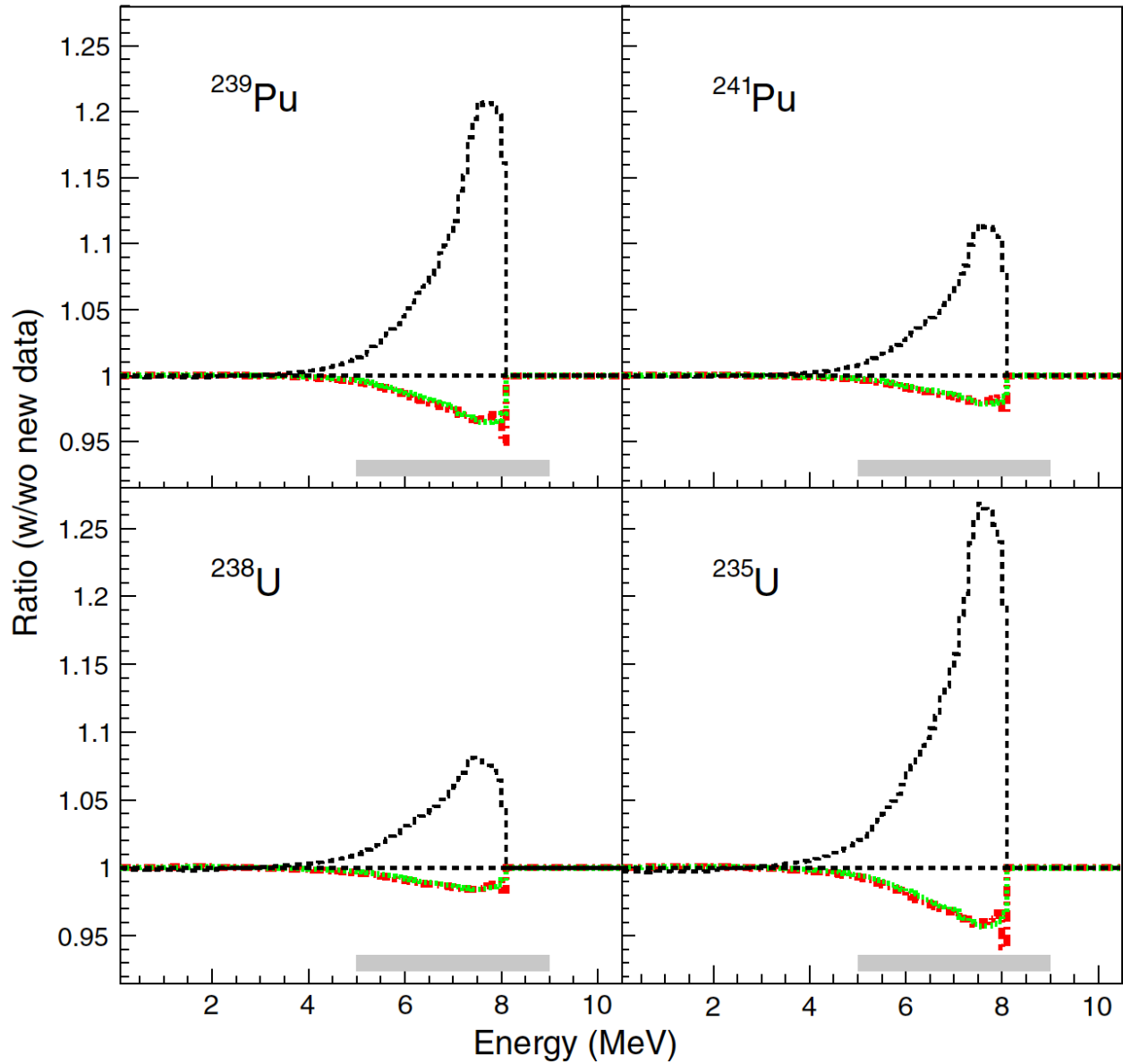

92Rb impact
Zakari-Issoufou et al.
PRL 115.102503(2015)

Another application: prediction of the neutrino spectrum from reactors for non-proliferation

	235U	239Pu
Released E per fission	201.7 MeV	210.0 MeV
Mean neutrino E	2.94 MeV	2.84 MeV
Neutrinos/fission >1.8 MeV	1.92	1.45
Aver. Int. cross section	$3.2 \times 10^{-43} \text{cm}^2$	$2.8 \times 10^{-43} \text{cm}^2$

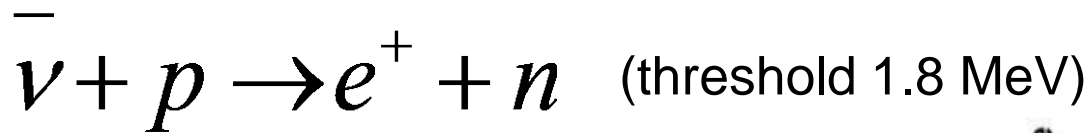

•Relevance for non-proliferation studies (working group of the IAEA). Neutrino flux can not be shielded. Study to determine fuel composition and power monitoring. Non-intrusive and remote method.

•Recently performed experiment to study some Rb, Sr, Y, Nb, I and Cs (IGISOL, trap assisted TAS) (Fallot, Tain, Algora), analysis by V. Guadilla

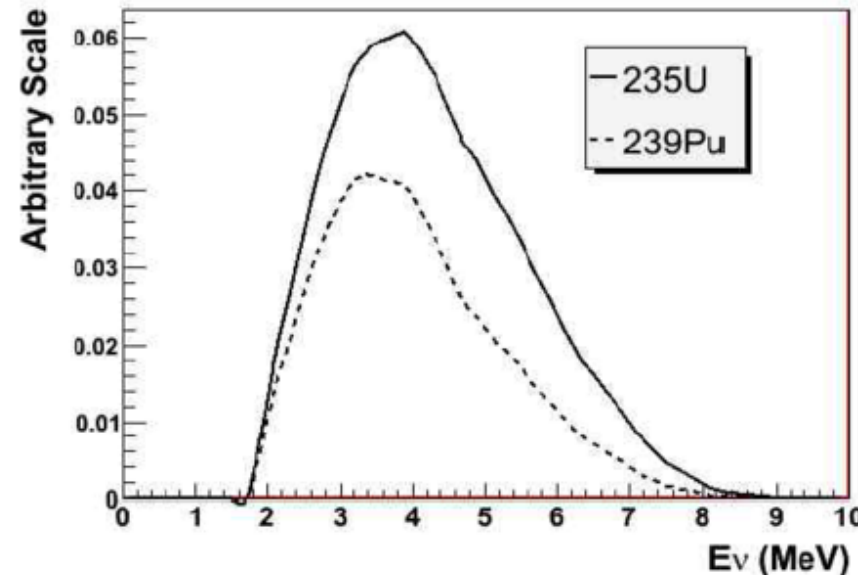

Collaboration

Univ. of Jyväskylä, Finland

CIEMAT, Spain

UPC, Spain

Subatech, France

Univ. of Surrey, UK

MTA ATOMKI, Hungary

PNPI, Russia

LPC, France

IFIC, Spain

GSI, Germany

Special thanks to the students working in the project:

E. Valencia, S. Rice, A. -A. Zakari-Issoufou, V. Guadilla

D. Jordan (not an student anymore)

Discussions with and slides from: J. L. Tain, V. Guadilla are acknowledged

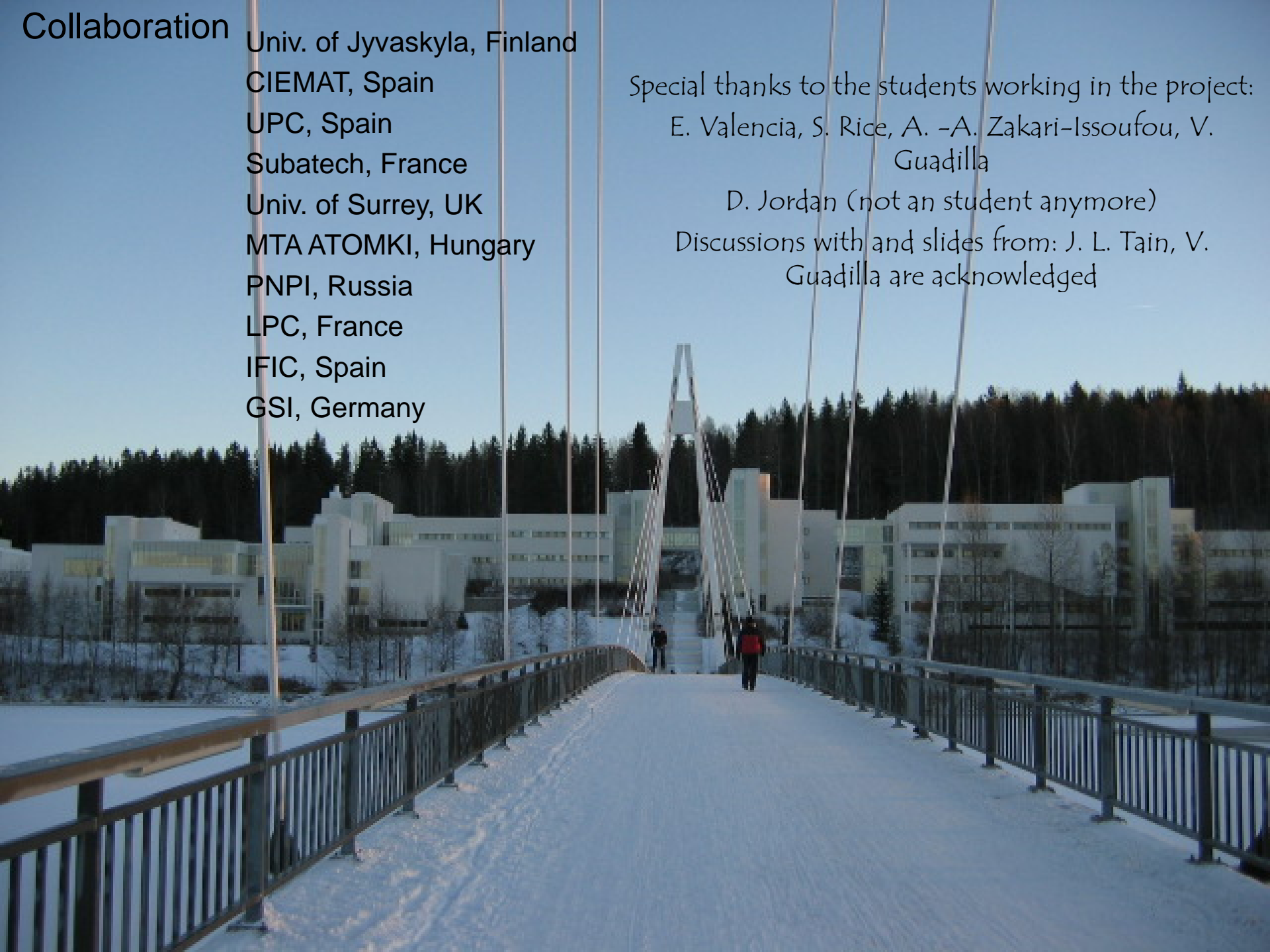



Integral Benchmark Experiments on a Large Copper Block using GELINA accelerator to validate ^{nat}Cu neutron inelastic scattering cross sections from different neutron cross section databases

Presented by: M. Pillon

ENEA C.R. Frascati, via E. Fermi, 45
00044 Frascati (Italy)
mario.pillon@enea.it

Experiment set-up

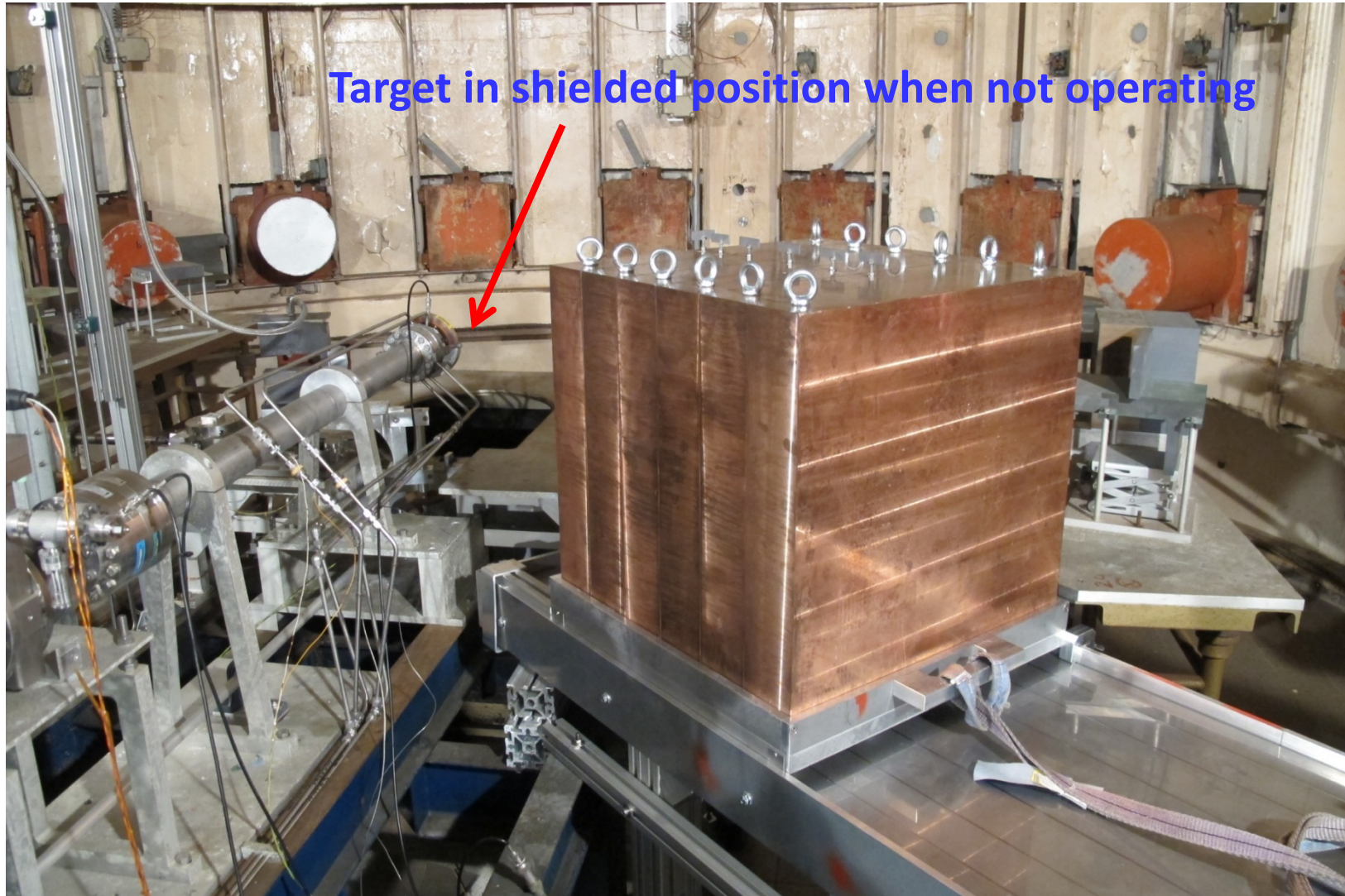

MCNP calculation model

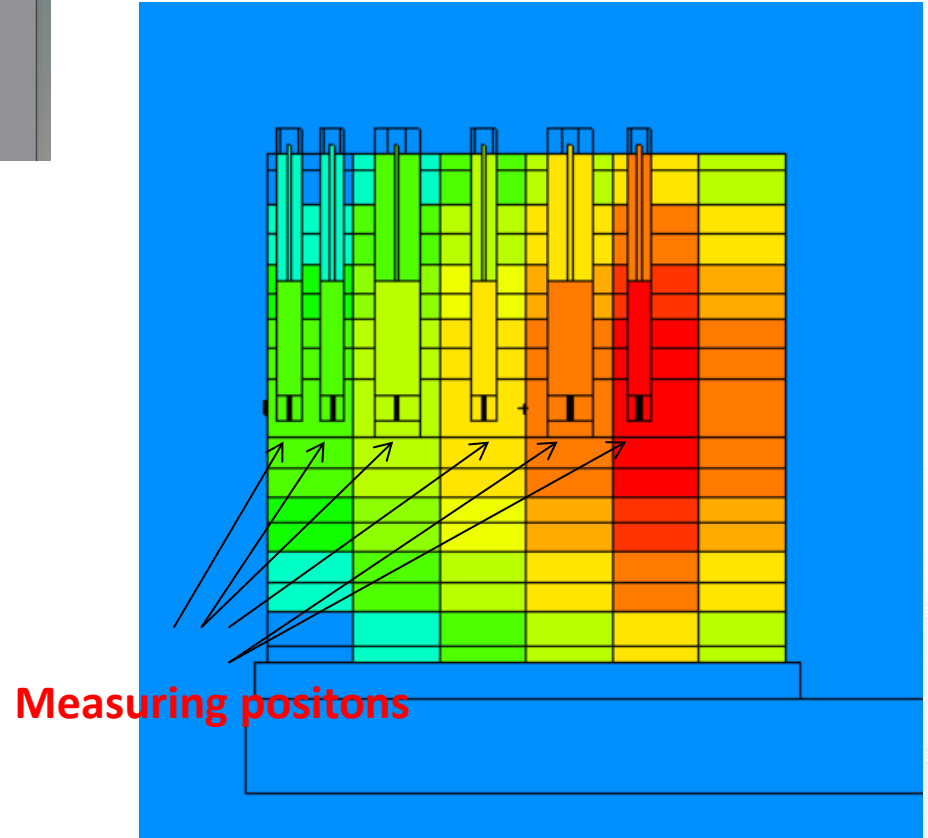
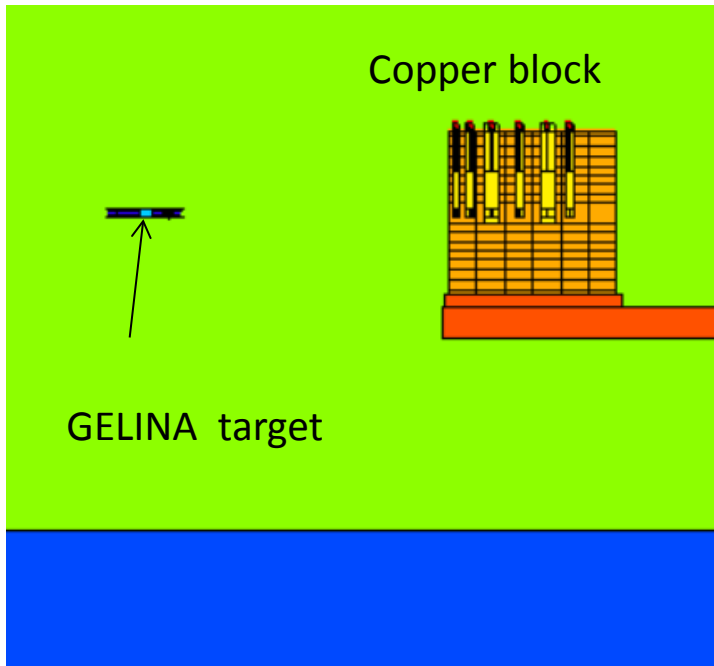
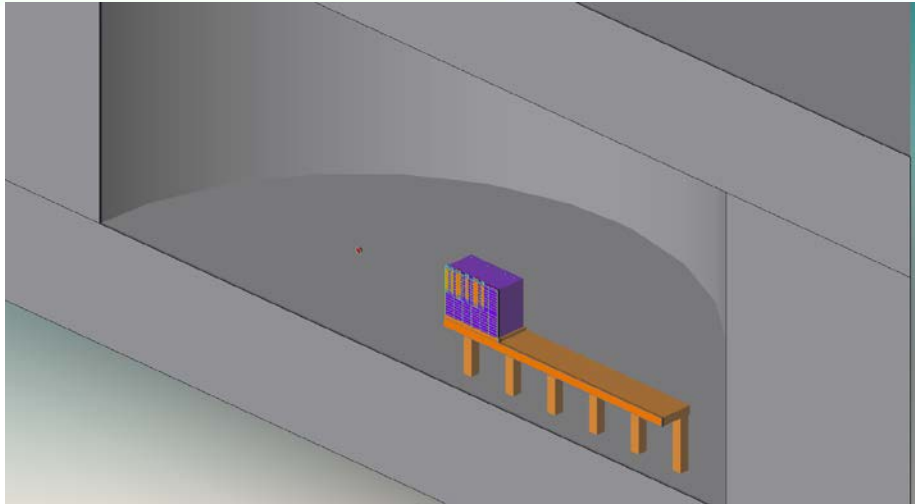

Calculation/Experiment comparison

Neutron transport calculation has been performed using MCNP6. The source neutron spectrum and the neutron yield normalization factor used were that obtained by STAYSL-PNNL unfolding. Three neutron transport libraries has been compared: FENDL3.1; JEFF33T2 and ENDF 7.1

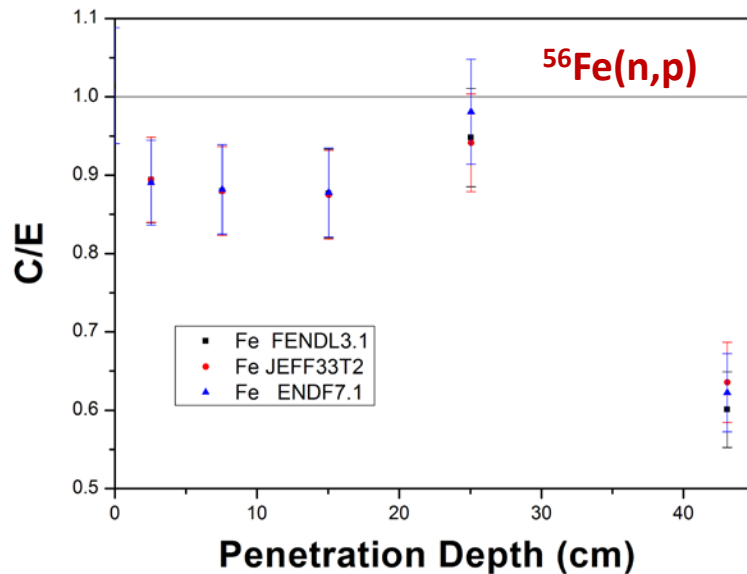

The experimental results are not well reproduced at great depth.

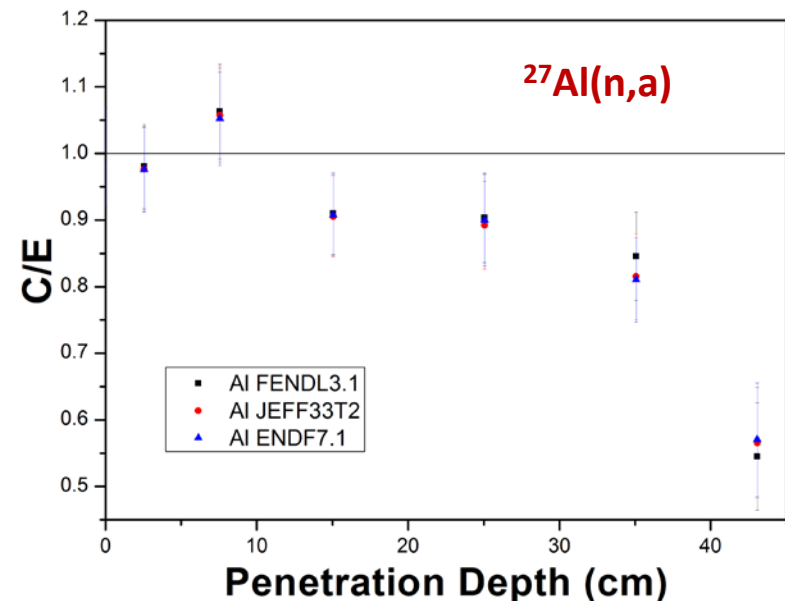

Calculation/Experiment comparison

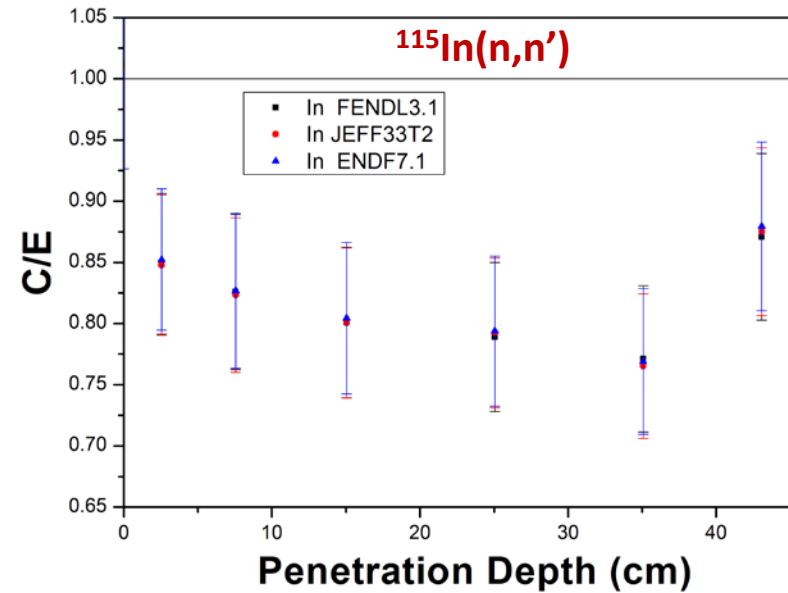
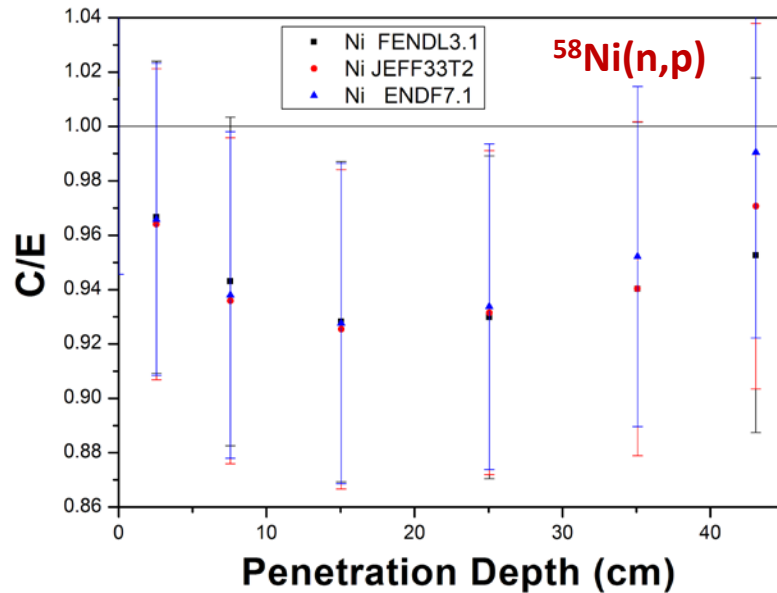

The epithermal neutrons from the source and the neutrons from room return are probably not well simulated.

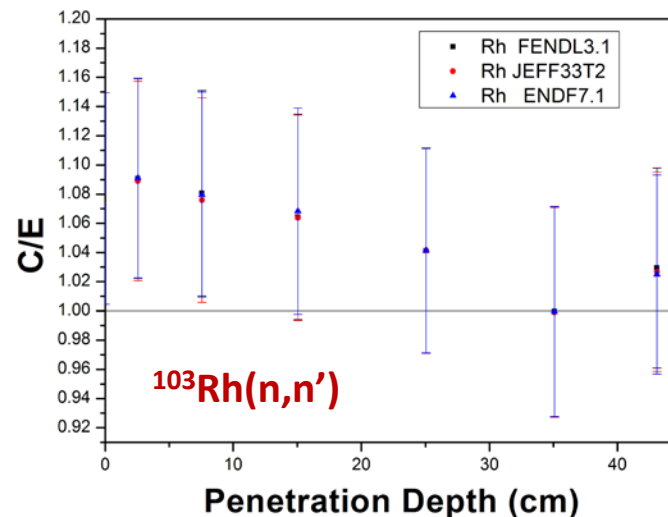

Calculation/Experiment comparison

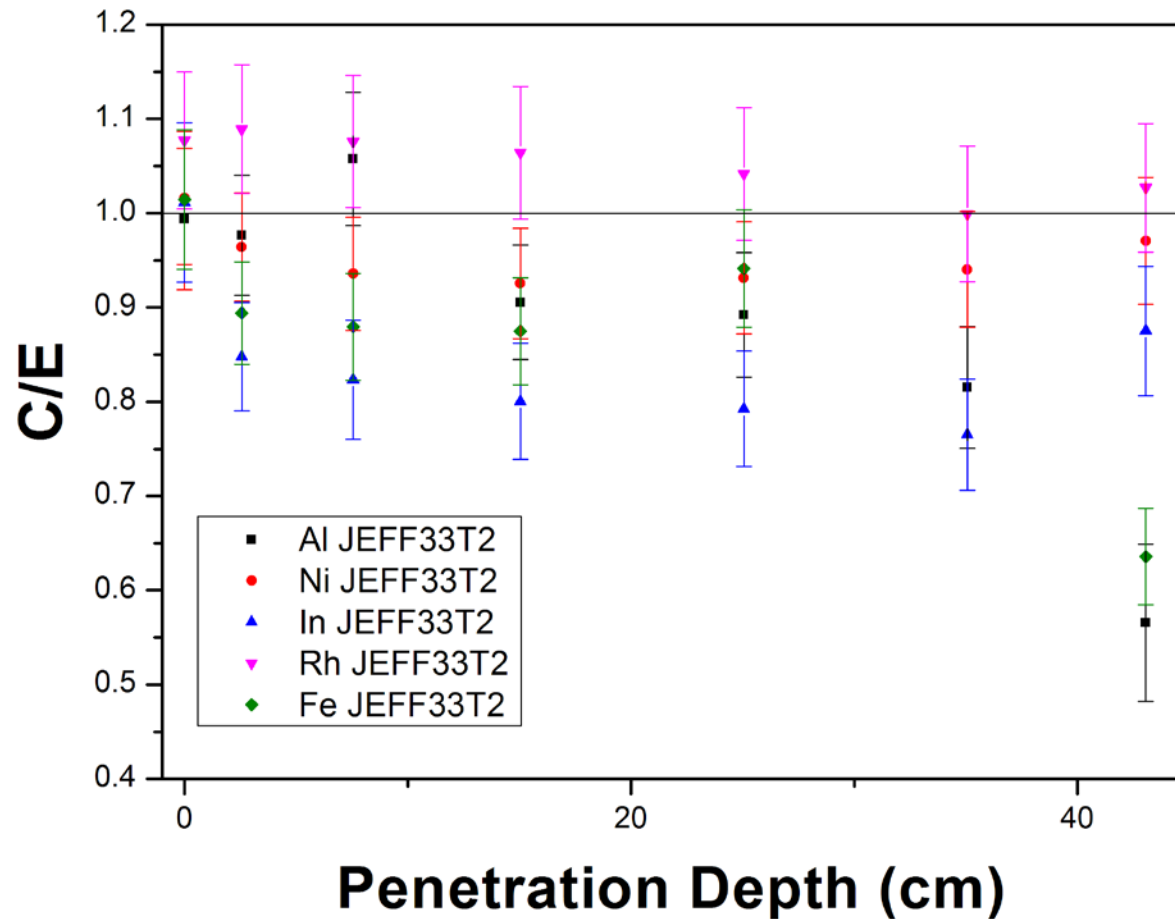

JEFF-33_T2 gives the better results (slightly)

Conclusions

This was the first time that GELINA photo-neutron generator was used to perform a benchmark transmission experiments.

A ^{nat}Cu block $60 \times 60 \times 60 \text{ cm}^3$ was irradiated and the neutron activation from threshold reactions measured at different depth inside the block has been compared to MCNP6 calculations.

The results from three cross section databases have been compared.

The C/E results, taking into account all the sources of uncertainties, are satisfactory, no large differences are observed among the result obtained using the three cross section databases but JEFF-3.3_T2 seems to slightly better predict the results

Acknowledgments

This work was supported by the European Commission within the FP7 EUFRAT program.

First simultaneous measurement of fission and gamma-emission probabilities for the understanding of the surrogate-reaction method

Jurado et al.

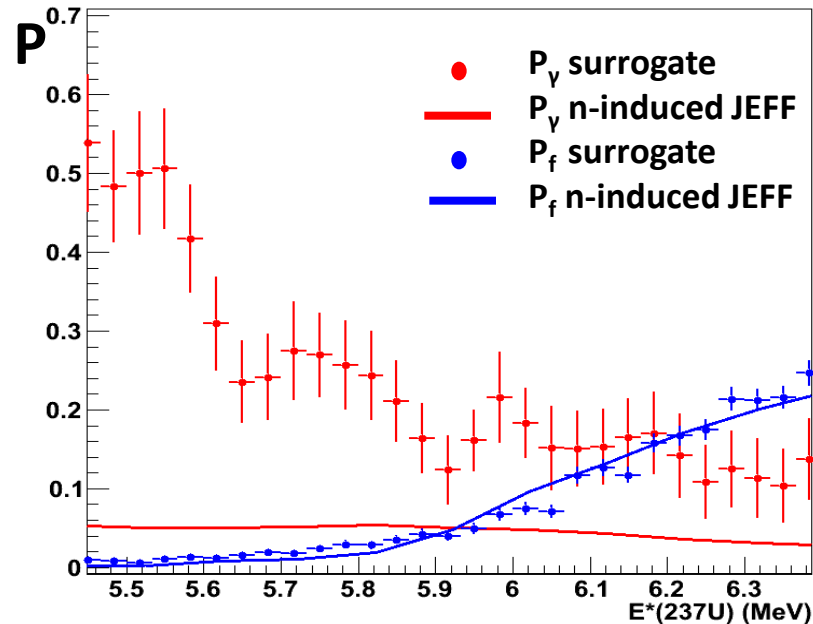

Fission is much less sensitive to the entrance channel than gamma-decay!

Comparison with statistical-model calculations

$$P_{surro,decay}(E^*) = \sum_{J^\pi} \underbrace{P_{surro}^{form}(E^*, J^\pi)}_{\text{Preliminary DWBA calculations by I. Thompson, J. E. Escher, UCRL-TR-225984 (2006)}} \cdot \underbrace{G_{decay}(E^*, J^\pi)}_{\text{Preliminary calculations based on extended R-Matrix theory by O. Bouland. Parameters tuned with neutron-induced cross sections}}$$

Preliminary DWBA calculations by I. Thompson, J. E. Escher, UCRL-TR-225984 (2006)

Preliminary calculations based on extended R-Matrix theory by O. Bouland. Parameters tuned with neutron-induced cross sections

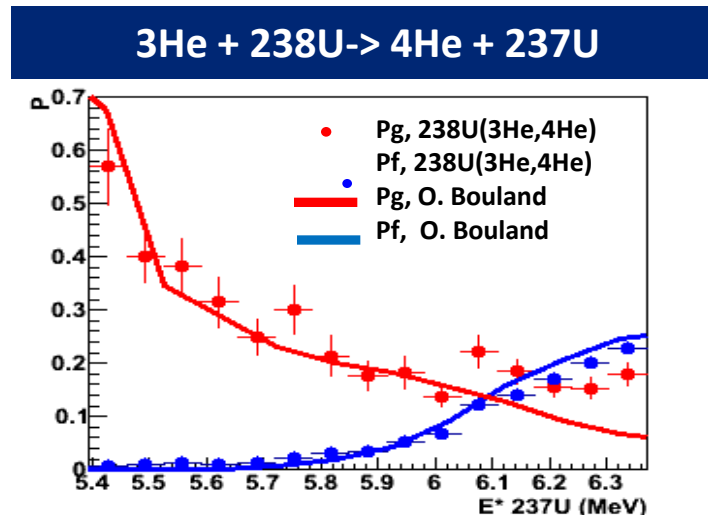

Good reproduction of our data! This means that we can proceed the other way around and use surrogate data to tune model parameters in order to infer n-induced cross sections.

Heavy-ion storage rings

The Experimental Storage Ring (ESR) at GSI

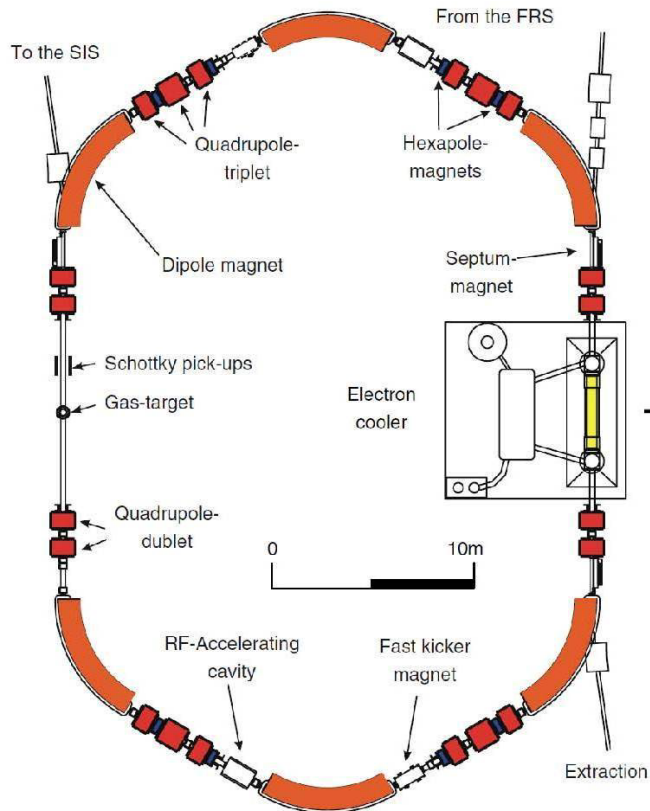

- Beam cooling → Excellent beam-energy resolution of few hundreds keV at 10 A MeV, beam size 1 mm!!
- In-ring gas-jet targets (H₂, D₂, ³He, ⁴He) with 10¹⁴/cm². Effective target thickness increased by ~10⁶ due to revolution frequency!
- Pure beams, pure targets (no contaminants, no backing)!
- Pure isomeric beams!

**Challenge: Detectors in Ultra-High Vacuum (10⁻¹¹ mbar)
First reaction cross-section measurement at the ESR!
B. Mei et al., Phys. Rev. C 92 (2015) 035803**

Decay-probability measurements in inverse kinematics inside a storage ring

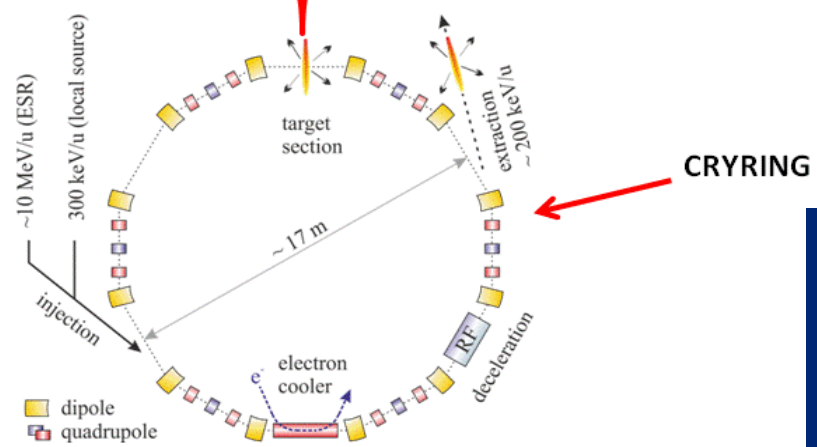
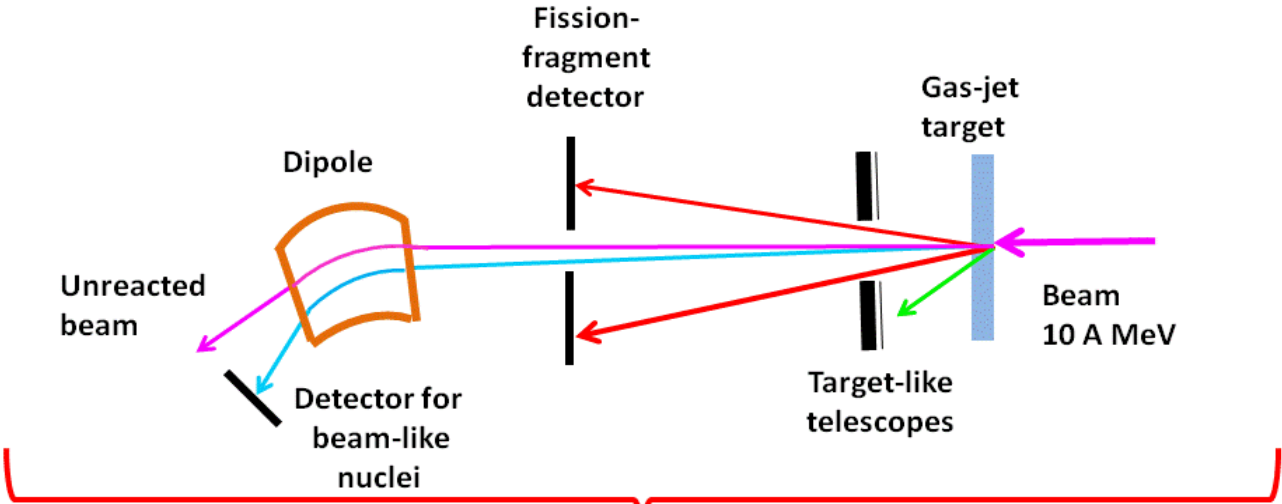

All open decay-channel probabilities can be measured simultaneously with high efficiency for very short-lived nuclei! Measurements possible in the next few years.

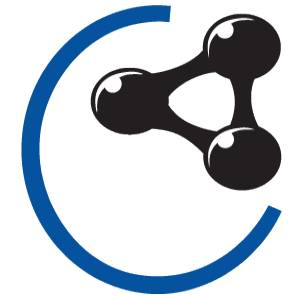

Research Centre Rez, Czech Republic

Neutron Spectra Measurement and Calculations using Data Library **JEFF-4.0T1** in Iron Benchmark Assemblies

(used files: JEFF-4.0T1, calculated in 27.2.2017)

Laboratory report **No. 20170227, version 1**

B. Jansky,^{1,*} J. Rejchrt,¹ A. I. Blokhin,²

¹ Department of Neutron Physics, Research Centre, Rez, Czech Republic

² Nuclear Safety Institute, Russian Academy of Sciences, Moscow, Russia

2. Methodology of calculation and measurement



2.1. Benchmark assemblies

The spherical shape of assemblies (Fe, Ni, H₂O, D₂O, ...) and spherical neutron source is used for calculation because this geometry represents the simplest one-dimensional (1D) task. As a matter of fact, the assembly is a 3D object.

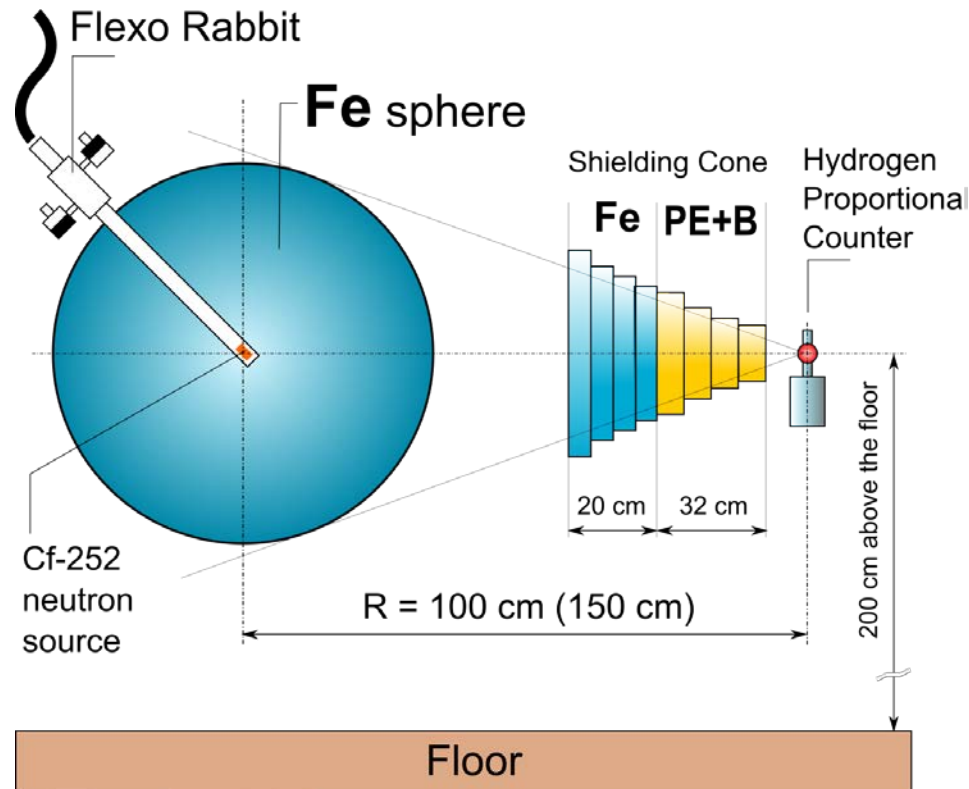

3. Neutron spectrometry



Tab.A. Detectors used with neutron spectrometers

Detector type	Type	Pressure	Dimension	Energy range [MeV]
Proportional Counter filled by Hydrogen (HPD)	NOK145	100 kPa	Ø 40 mm	0.01-0.3
	NOK445	400 kPa		0.2-0.8
	NOK1045	1000 kPa		0.5-1.3

