

# Japanese Activities in Nuclear Data Measurement

Hideo HARADA

*Japan Atomic Energy Agency*

on behalf of

Masayuki IGASHIRA<sup>1</sup> and Hideo HARADA<sup>2</sup>

<sup>1</sup>*Tokyo Institute of Technology*

<sup>2</sup>*Japan Atomic Energy Agency*

# Nuclear Data Measurement in Japan

Nuclear data measurements are being performed intensively at several accelerator and reactor facilities in Japan:

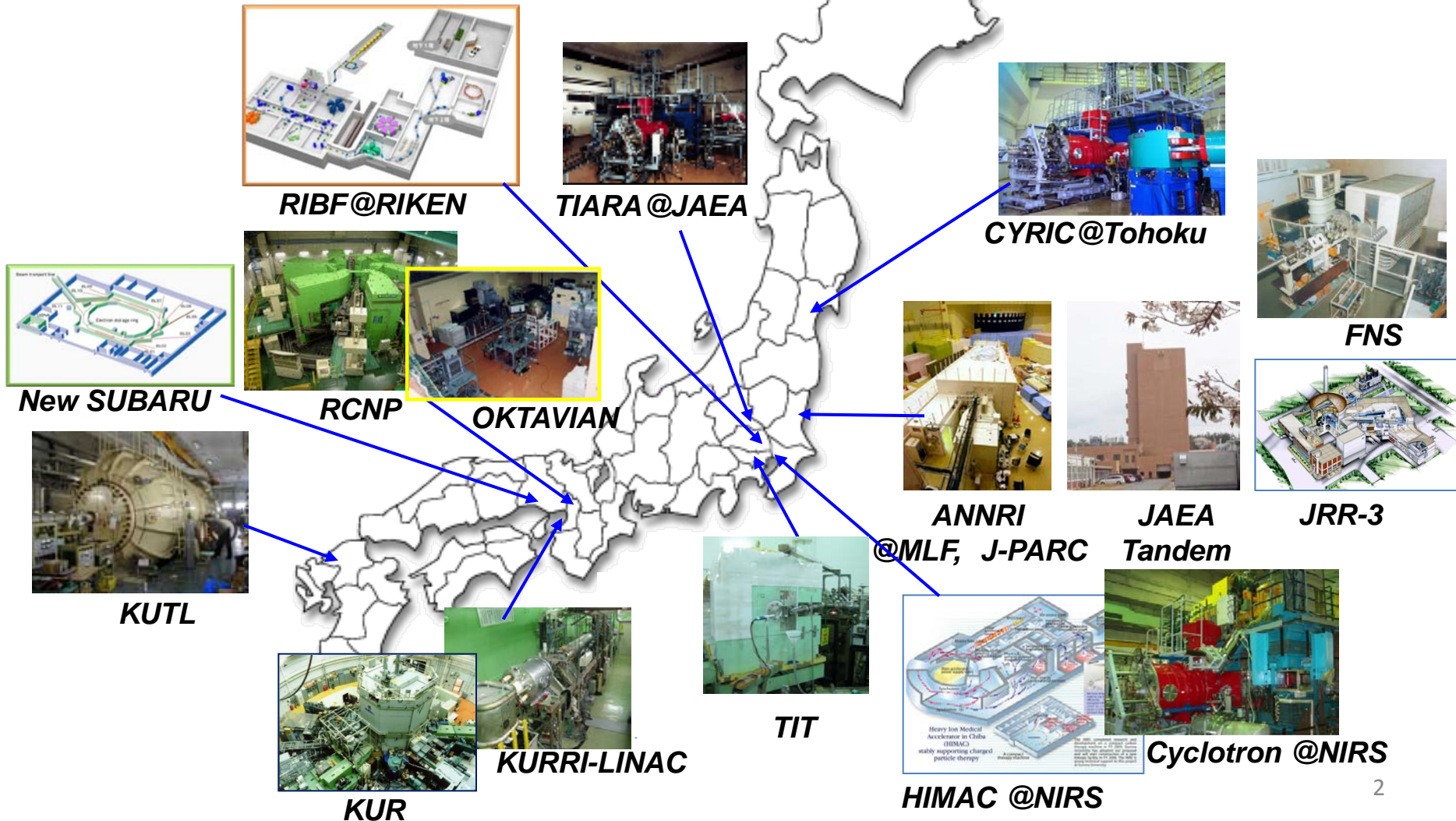

# A Working Group for Japanese Nuclear Data Measurement Network (JNDM-net)

A new working group **in the Japanese Nuclear Data Committee** has been established in 2012 JFY to make a cooperative network among researchers involved in nuclear data measurements and to discuss the strategy for nuclear data measurements.

Leader of JNDM-net: Y. Watanabe (Kyusyu Univ.)

Sub-Leader: T. Sanami (KEK), A. Kimura (JAEA), Y. Iwamoto (JAEA)

(<http://meteor.nucl.kyushu-.ac.jp/ndmnet/>)

# Activities by J-PARC/MLF/ANNRI collaboration

JAEA (Harada Group)

Tokyo Institute of Technology (Igashira Group)

Hokkaido Univ. (Kiyanagi Group)

Kyoto Univ. (KURRI Group)

Contact :

Hideo HARADA

Nuclear Science and Engineering Directorate

Japan Atomic Energy Agency

[harada.hideo@jaea.go.jp](mailto:harada.hideo@jaea.go.jp)

# J-PARC Materials and Life Science Experimental Facility

Building dimension :

Width : 70m

Length : 146m

Height : 30m

Exp. Hall Height : 22m

Target remote handling room

Cooling systems  
(Basement)

1MW Spallation Target Station

Proton beam line

**BL04: ANNRI**

Spallation Mercury target

Experimental hall

3GeV, 1MW  
proton beam

23 neutron beam lines will be Installed  
in experimental halls under present  
design.

**300 kW  
Today**

J-PARC MLF,  
Taken from HP  
of J-PARC

# Experiments@TOF facility, “ANNRI”

Accurate Neutron-Nucleus Reaction measurement Instrument)

side view of the ANNRI

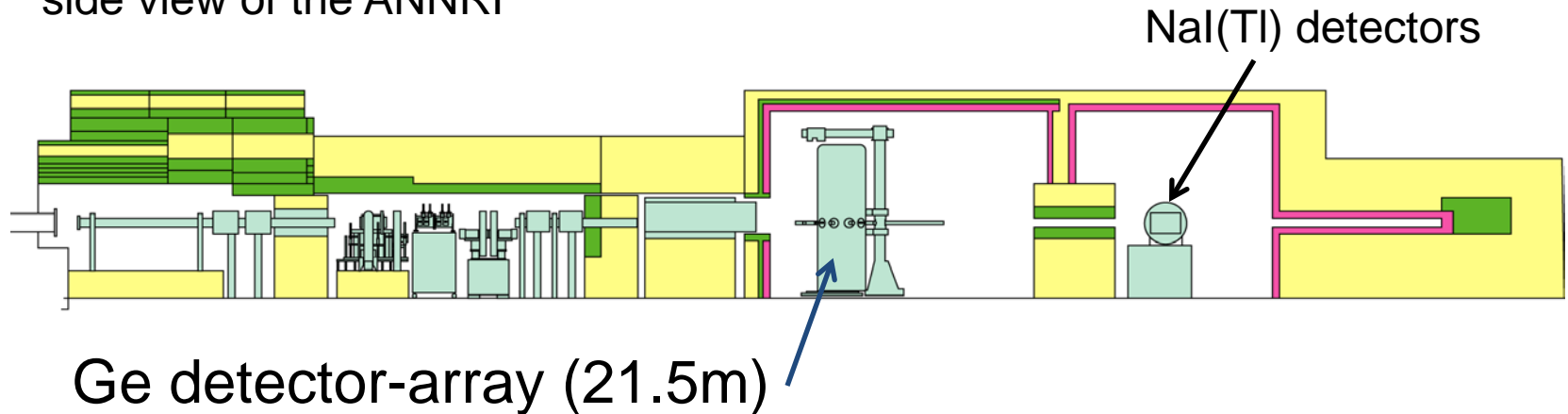

Energy-integrated intensities	1 MW (Future)	210 kW
1.5-25 meV	$4.3 \times 10^7$ n/s/cm <sup>2</sup>	$9.1 \times 10^6$ n/s/cm <sup>2</sup>
0.9-1.1 keV	$6.3 \times 10^6$ n/s/cm <sup>2</sup>	$1.2 \times 10^6$ n/s/cm <sup>2</sup>

K. Kino, *et. Al.*, NIM-A, **626**, 58 -66 (2011).

**300 kW Today**

# Measurements using NaI(Tl) Spectrometer

- Used for:

- Complementary use to Ge array
- Measurement in the high energy range

- Detectors

- 90° detector: 13" diam. × 8" long
- 125° detector: 8" diam. × 8" long

- Shielding

- Borated polyethylene, Pb, <sup>6</sup>LiH, Cd

- Data acquisition update

(T. Katabuchi)

- Multi-stop time digitizer
- TOF, pulse height, pulse width are recorded sequentially

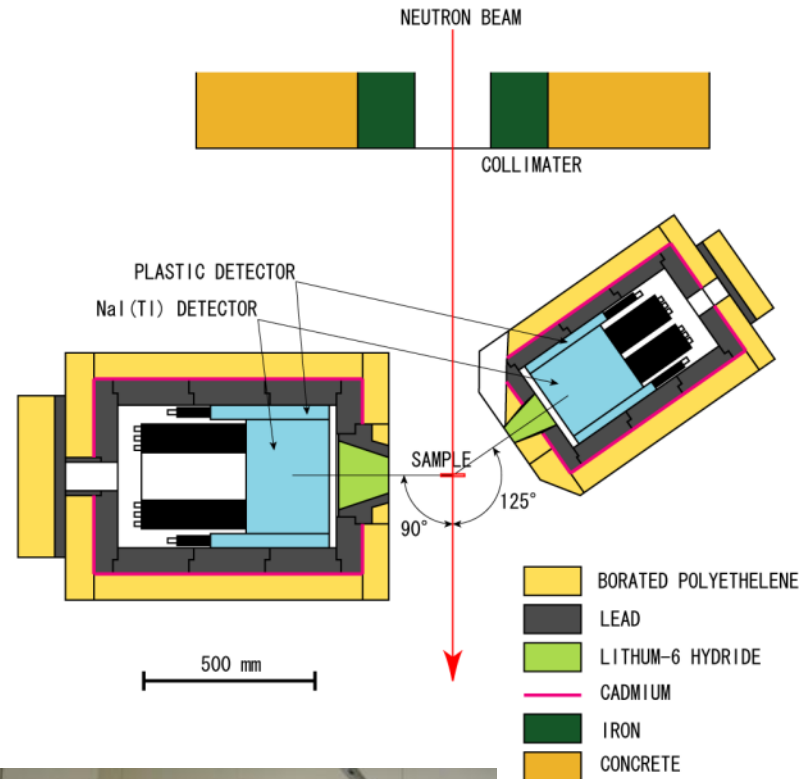

# Neutron Capture Cross Section of $^{99}\text{Tc}$

Preliminary

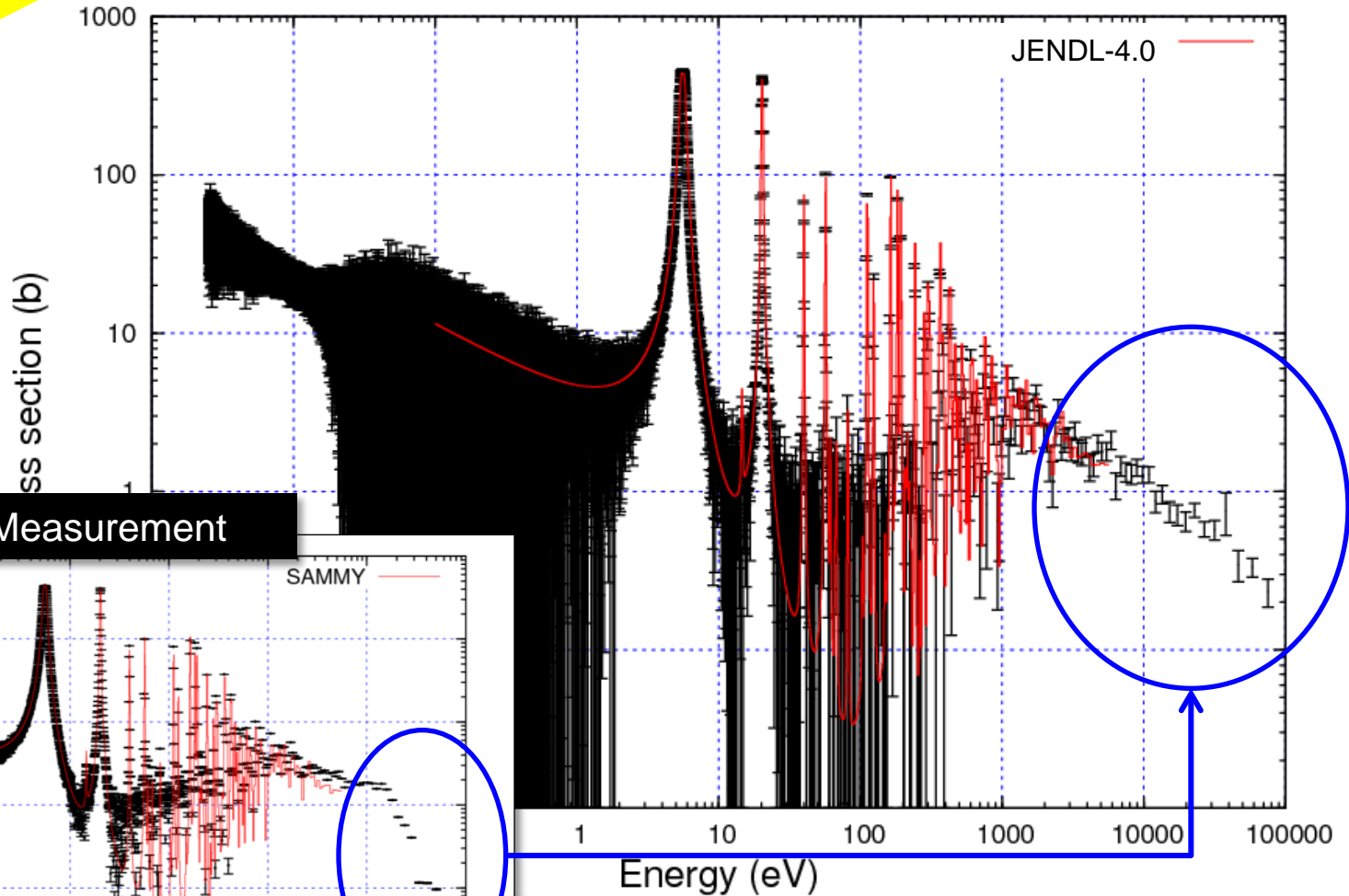

Previous Measurement

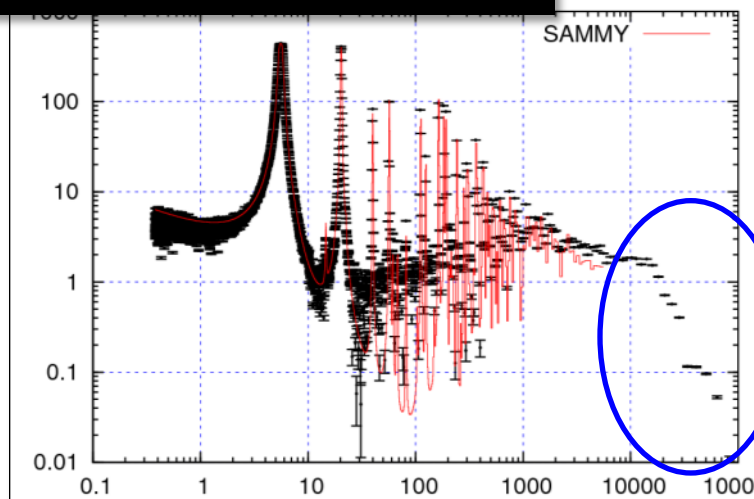

High energy limit was extended with a new method using pulse width analysis

# Measurements using Ge Spectrometer

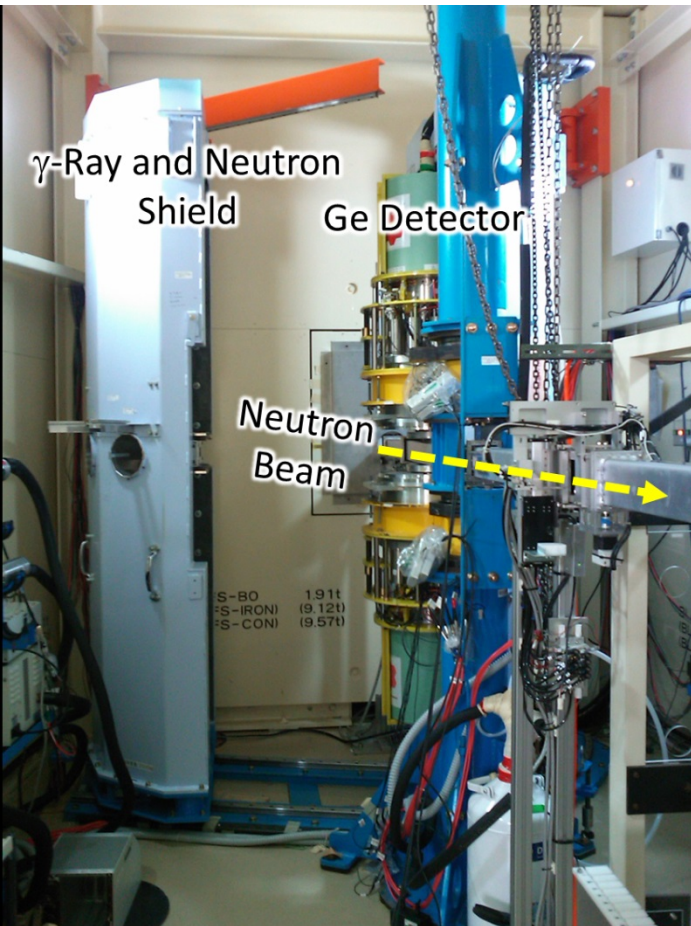

Our spectrometer has

- 2 cluster-Ge detectors (7 Ge crystals are installed in the detector)
- 8 coaxial-Ge detectors
- Compton suppressing BGO detectors  
⇒ 22 Ge Crystals.

Energy resolution for 1.33MeV  $\gamma$ -rays:

5.8keV (for 200kevents/s),

2.4keV (for 20kevents/s) [1]

Peak efficiency for 1.33MeV  $\gamma$ -rays:

$3.64 \pm 0.11 \%$

[1] T. Kin et. al., *the 2009 NSS-MIC Conf. Rec.*, N24-2, (2009).

# Neutron Capture Cross Sections of LLFPs and related stable isotopes

$^{112}\text{Sn}$

Atsushi KIMURA, JAEA

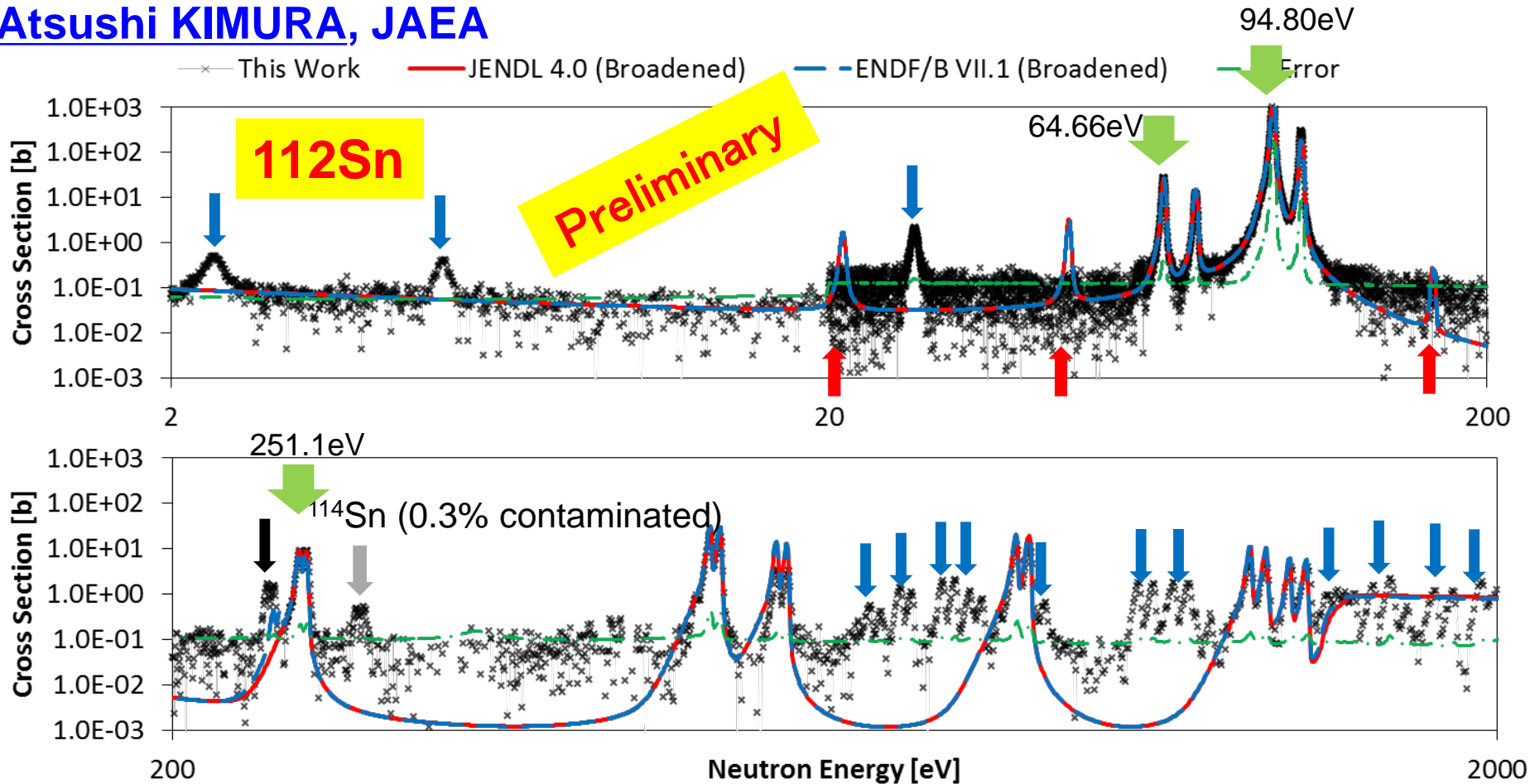

- ➡ 14 unknown resonances were observed
- ➡ Resonances at 21, 46, and 251 eV were not observed,
- ➡ The resonance at 240 eV is listed in ENDF B-VII but not listed in JEBDL 4.0.

**$^{108}\text{Pd}$**

**Preliminary**

**$^{105}\text{Pd}$**

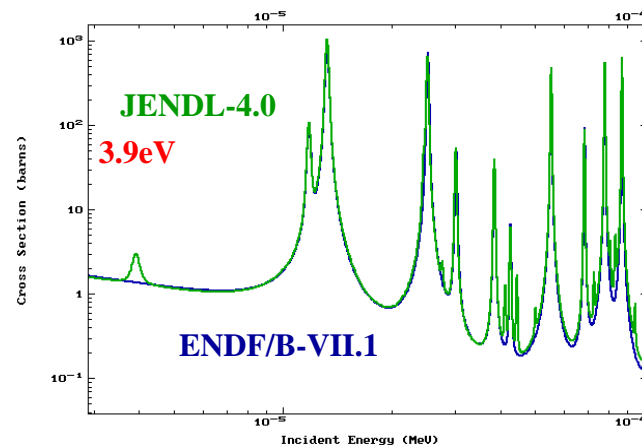
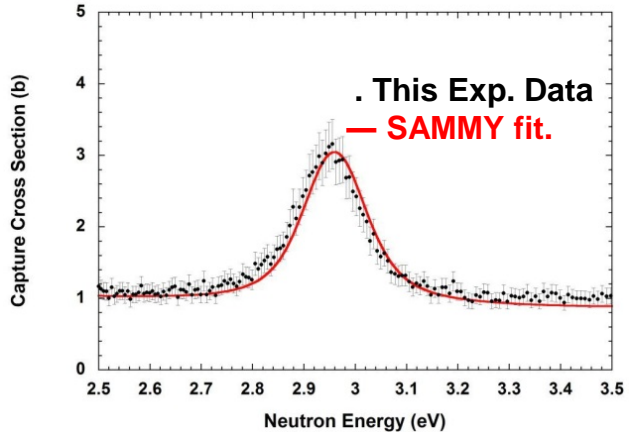
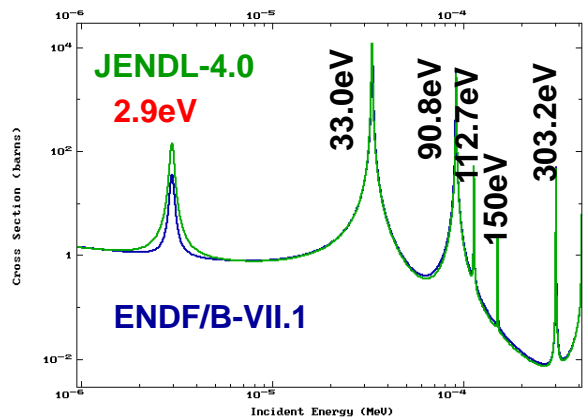

**3.9eV res. Are observed by ANNRI in  $^{105}\text{Pd}$ . Supports JENDL-4.0.**

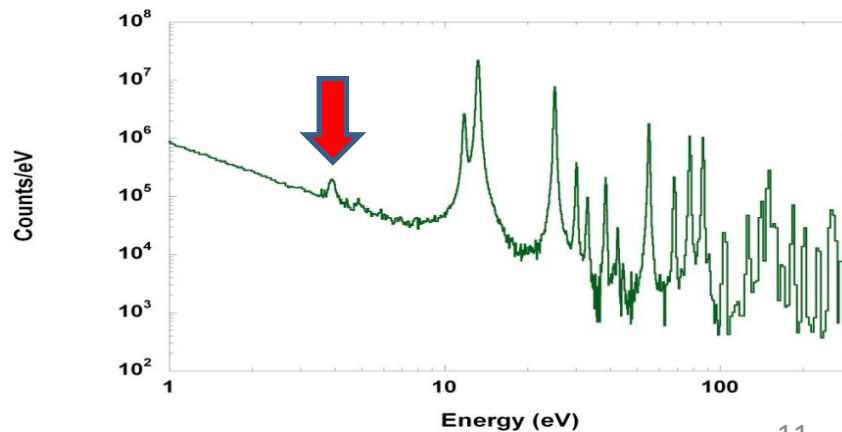

	$\Gamma_\gamma$ (meV)	$\Gamma_n$ (meV)
<b>This Work</b>	( 92 meV used)	<b>0.0018 (1)</b>
JENDL-4.0 (2010)	92	0.01
ENDF/B-VII.1 (2011)	91.8	0.00252
Coceva ('65)	90 (2)	0.00504 (5)

Measurements of capture gamma rays from the neutron resonances of  $^{74}\text{Se}$  and  $^{77}\text{Se}$ .

- Sample :  $^{74}\text{Se}$  0.25mg,  $^{77}\text{Se}$  87mg, isotopic purity > 99%.
- Measurement time : 32( $^{74}\text{Se}$ ), 36( $^{77}\text{Se}$ ) hours (JSNS=280kW)

**$^{74}\text{Se}$  27-eV resonance**

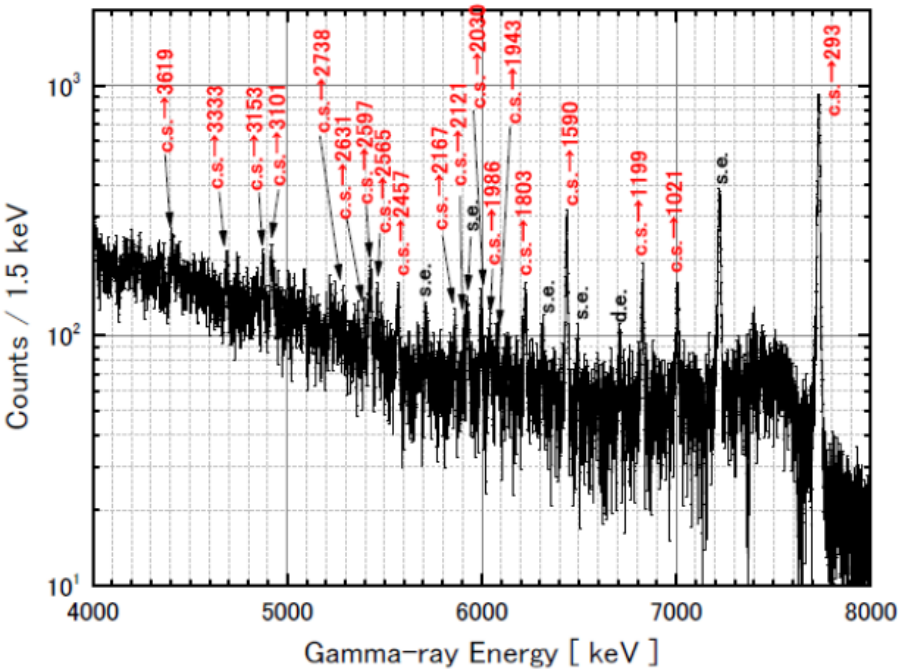

Net P.H. spectrum gated on the 27-eV resonance region

**$^{77}\text{Se}$  113, 212, 291, 342, 690, 864-eV resonances**

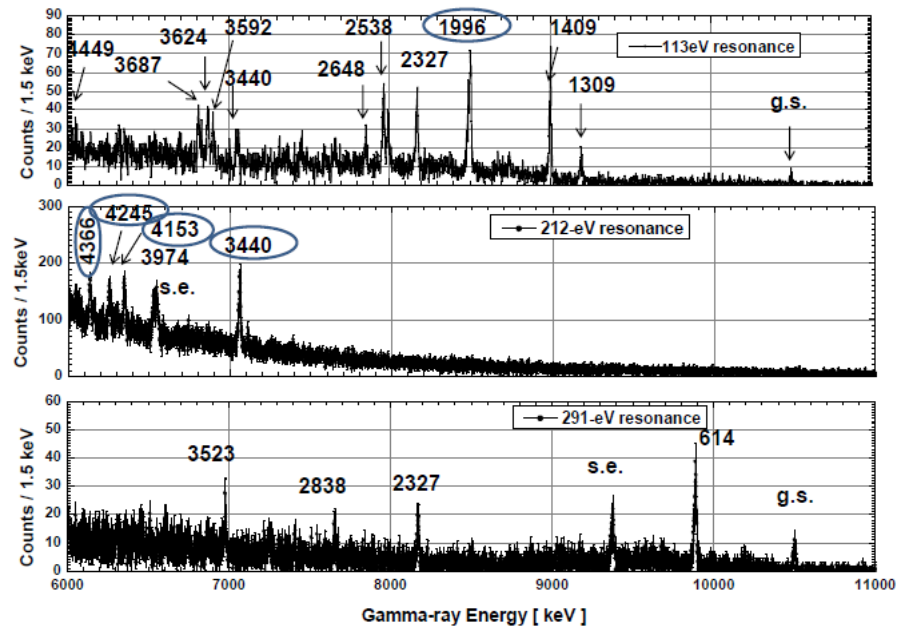

Net P. H. spectra gated on 113-, 212-, 291-eV resonances

The primary transitions reported in the previous work were indicated by blue circles.

# Tc-99

Koichi KINO, Hokkaido Univ.

Measurement of Capture Gamma Rays from the Tc-99 Neutron Resonances at the J-PARC/ANNRI

Primary gamma-rays were investigated for each resonance.

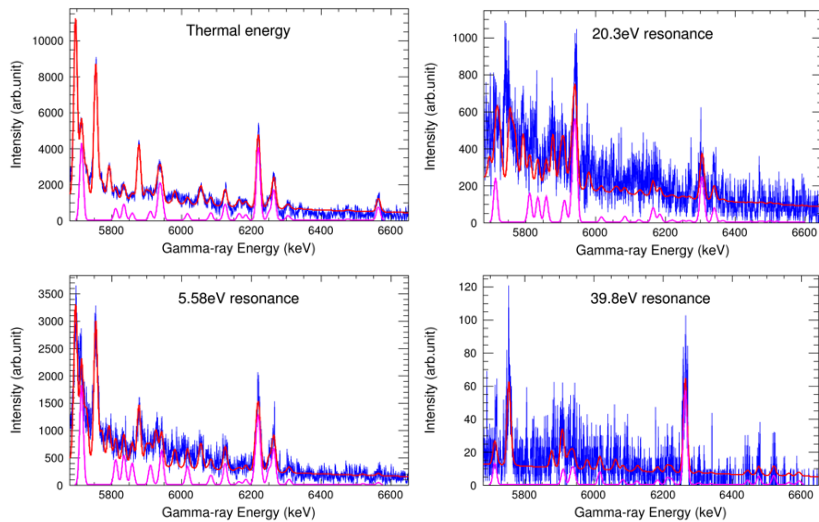
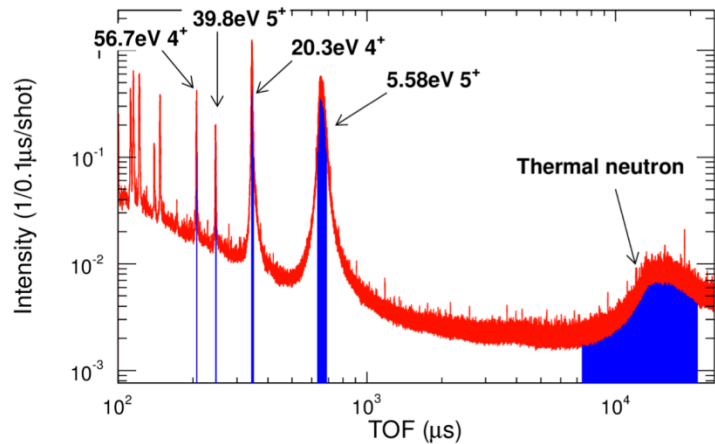

Red: All gamma-ray peaks + B.G.

Pink: Primary gamma-ray peaks

# $^{133}\text{Cs}$

Kaoru Y. HARA, JAEA

Measurements of the neutron capture reaction of  $^{133}\text{Cs}$  at J-PARC/ANNRI

Detector: NaI(Tl) detector

Sample:  $\text{Cs}_2\text{CO}_3$  11mg

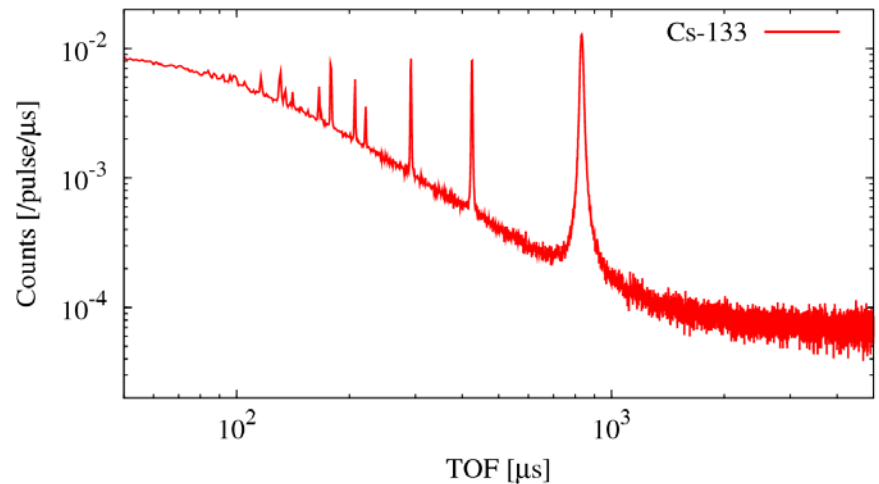

# Activities

## at Tandem Accelerator Facility of Japan Atomic Energy Agency

Contact :

Katsuhisa NISHIO

Advanced Science Research Center

Japan Atomic Energy Agency

[nishio.katsuhisa@jaea.go.jp](mailto:nishio.katsuhisa@jaea.go.jp)

# Tokai Campus, JAEA



J-PARC

Tandem facility

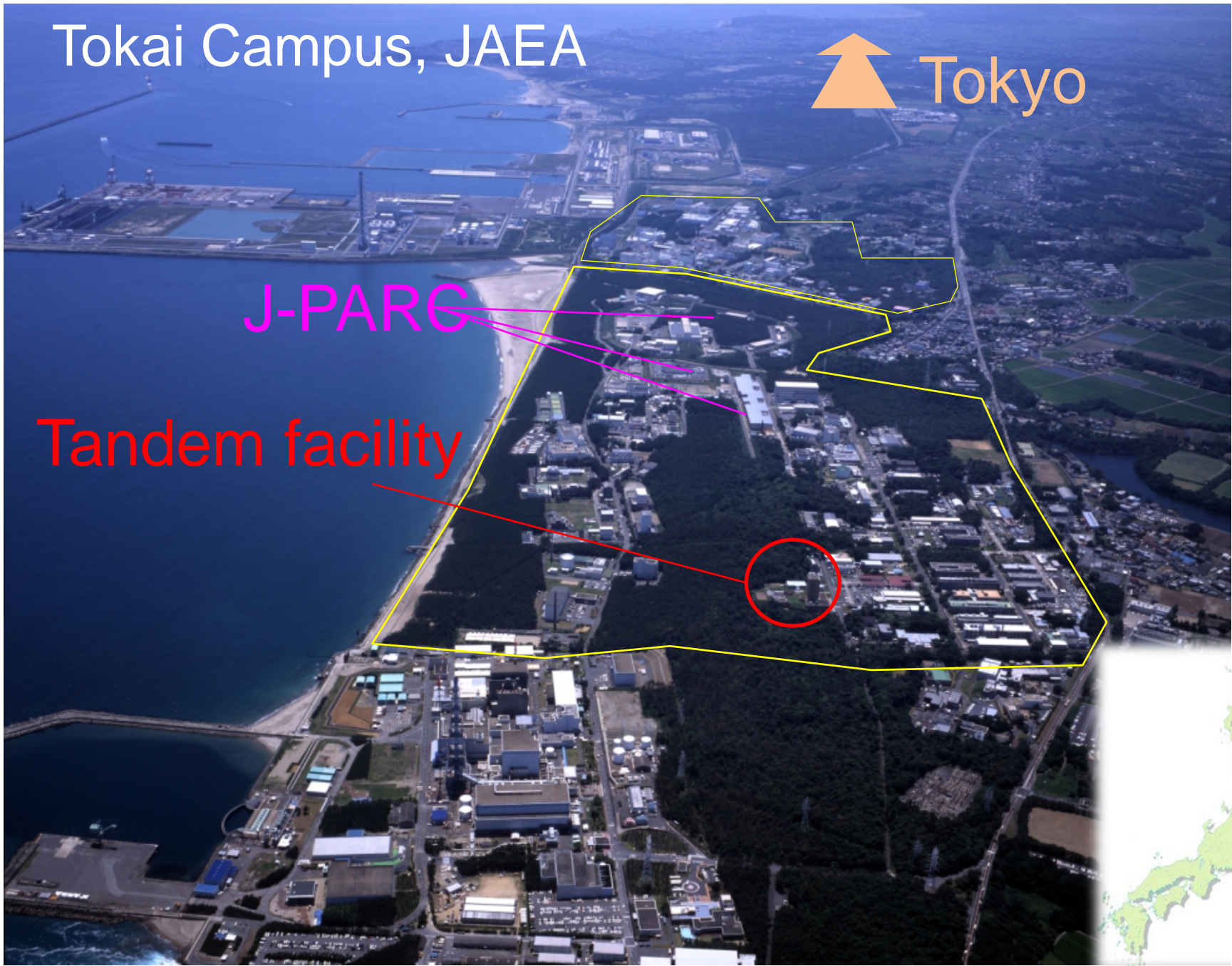



# Particle Identification

$^{18}\text{O} + ^{238}\text{U}$  ( $E=157.5$  MeV)

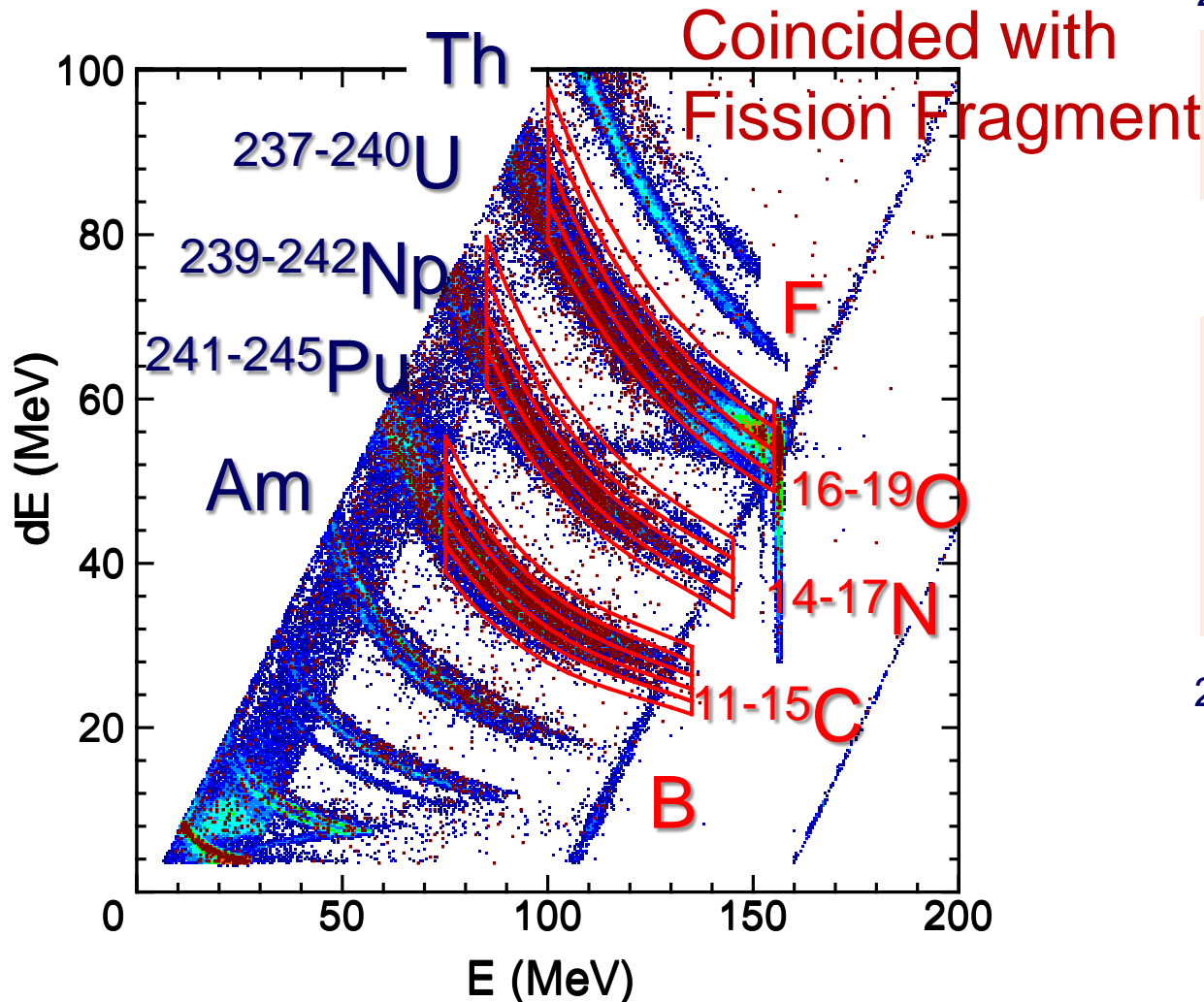

$^{240,239,238,237}\text{U}^*$

$n + ^{239}\text{U}$  (23.5 min)  
 $n + ^{237}\text{U}$  (6.8 day)

$^{242,241,240,239}\text{Np}^*$

$n + ^{241}\text{Np}$  (13.9 min)  
 $n + ^{240}\text{Np}$  (65 min)  
 $n + ^{239}\text{Np}$  (2.4 day)  
 $n + ^{238}\text{Np}$  (2.1 day)

$^{245,244,243,242,241}\text{Pu}^*$

$n + ^{243}\text{Pu}$  (4.9 hr)  
 $n + ^{241}\text{Pu}$  (14 yr)

# Fission Cross sections

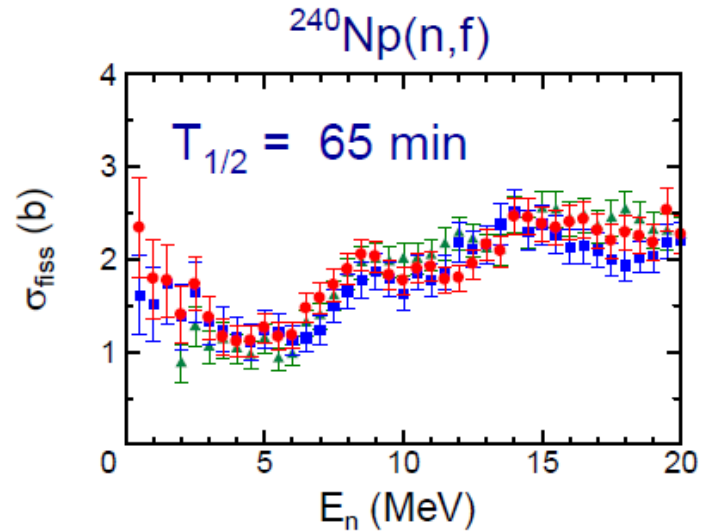
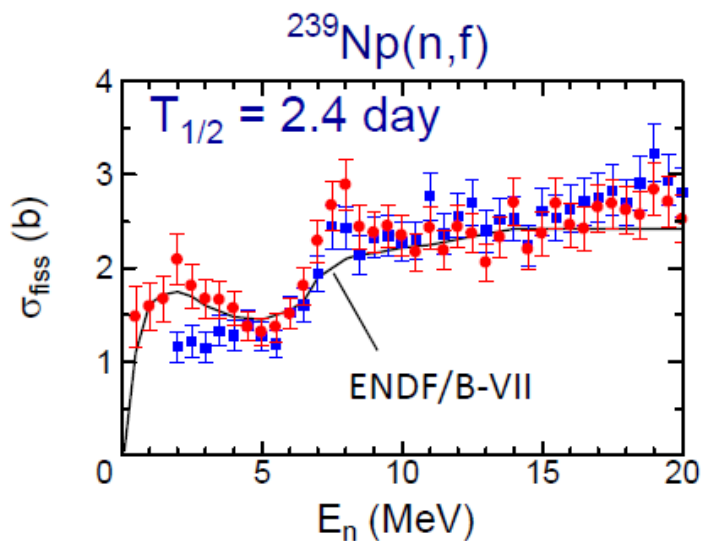
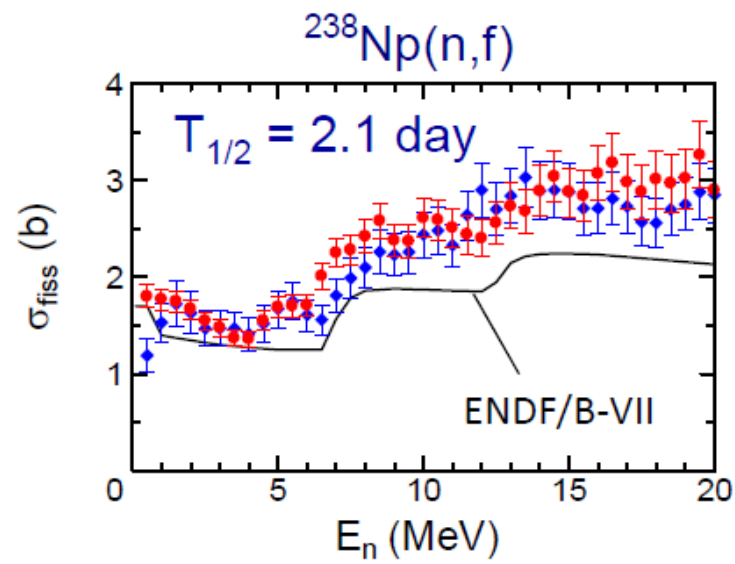
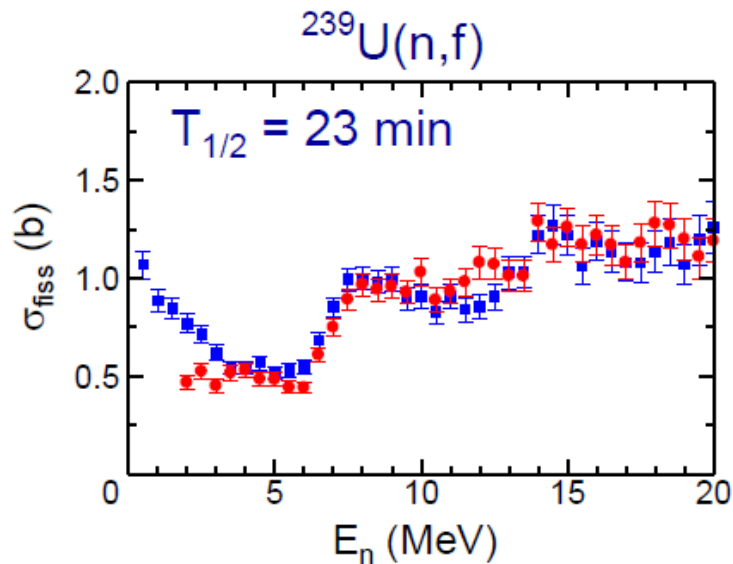



# Capture Cross Sections

## Surrogate reaction

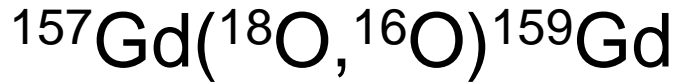
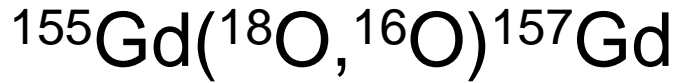

Gamma-ray detector,  $\text{LaBr}_3(\text{Ce})$   
Length = 5inch, Diameter = 4inch

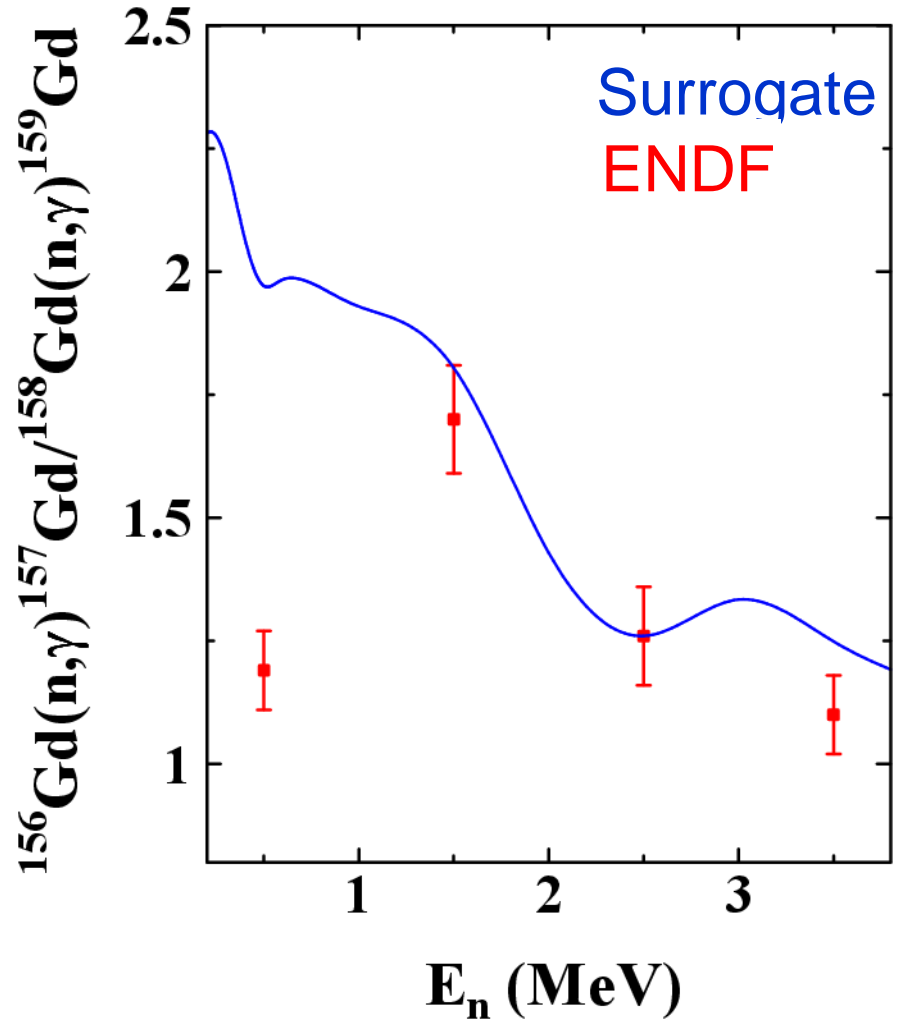

Reported in ND2013, New York

# Activities at Radiation Science Center, KEK

Sanami and Hagiwara Group

# Nuclear data measurement activities at High Energy Accelerator Research Organization (KEK)

## Systematic measurement of DDX on Carbon-induced fragment emission reactions for light-medium nuclei at 6 MeV/n

Experiment at NIRS-cyclotron facility

Bragg Curve Counter with at 30, 60,  
90 degrees emission angle

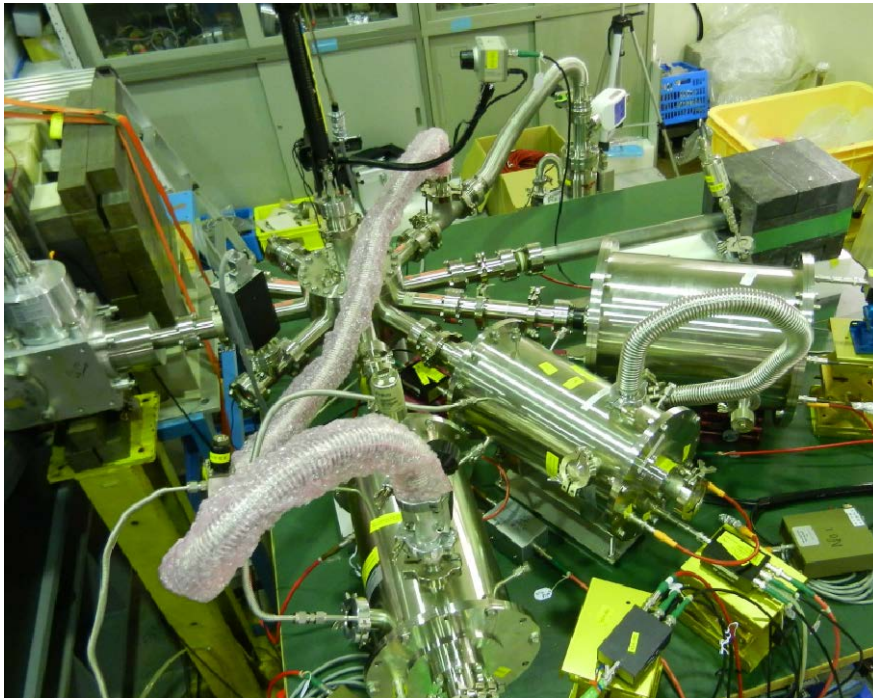

To cover sufficient energy range, range-  
energy particle identification and offline  
analysis with energy compensation for (i)  
and (ii) events, respectively

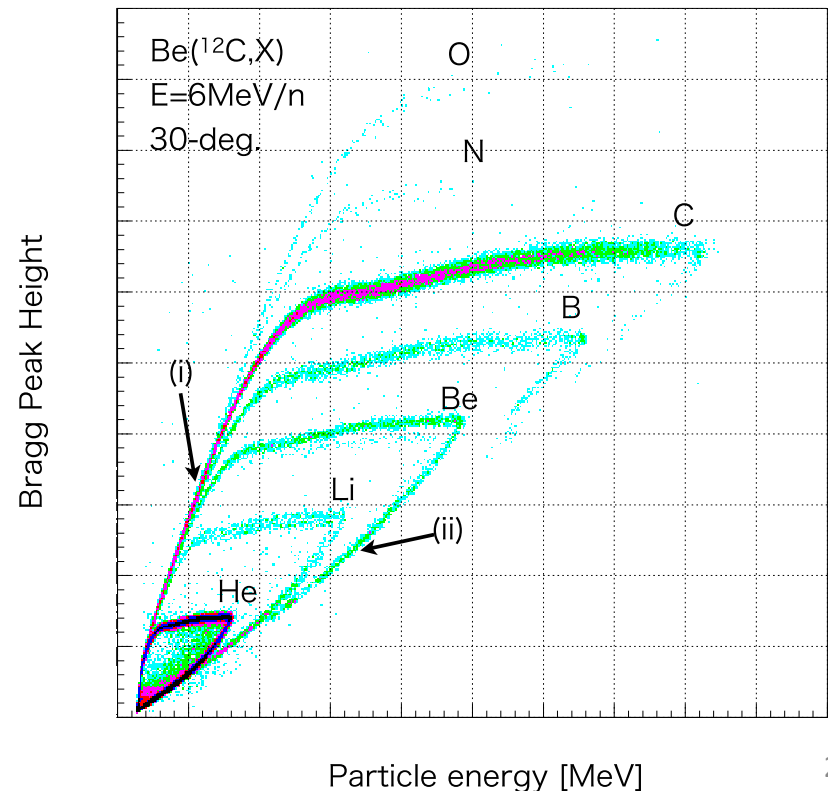

# Nuclear data measurement activities at High Energy Accelerator Research Organization (KEK)

Target : Be(5 $\mu$ m),C(205mg/cm<sup>2</sup>),Al(1 $\mu$ m),Ti(1 $\mu$ m),Cu(1 $\mu$ m)

Measured fragments: Li, Be, B, C, N, O

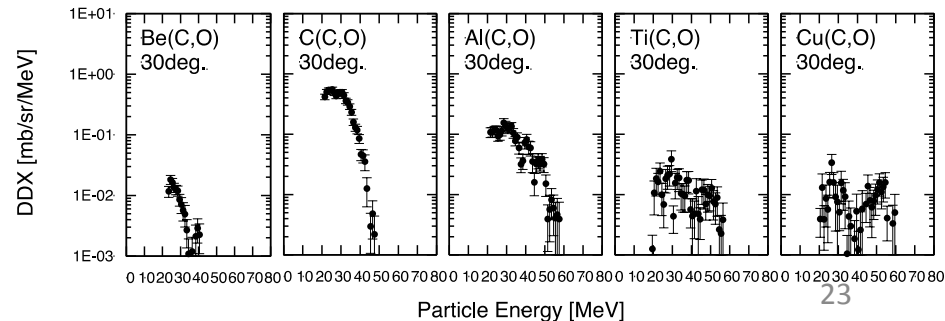
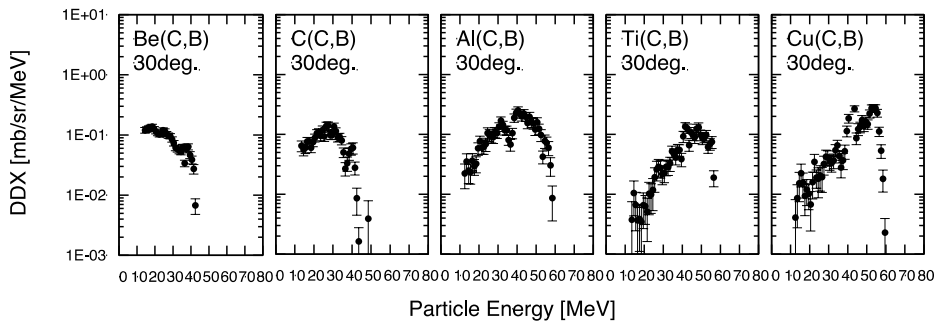
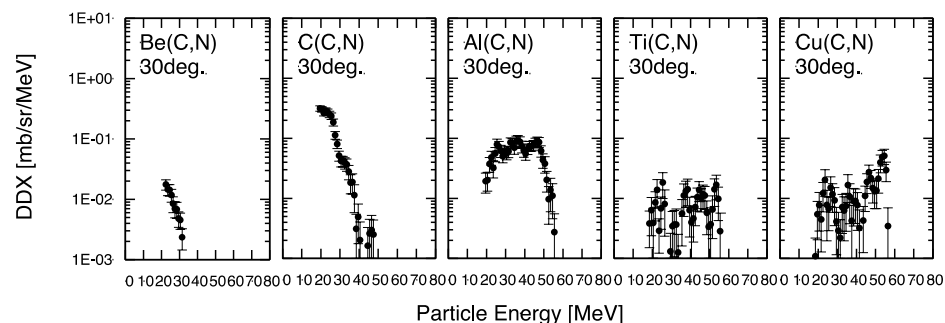
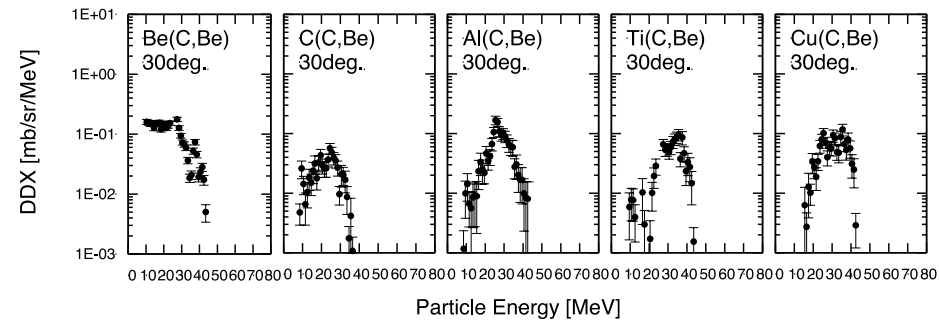
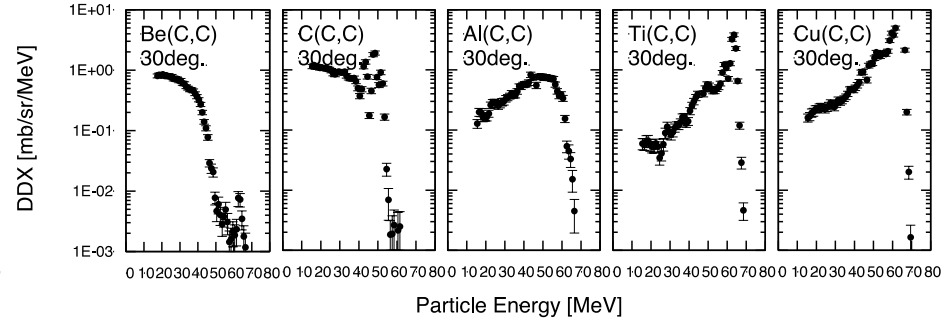
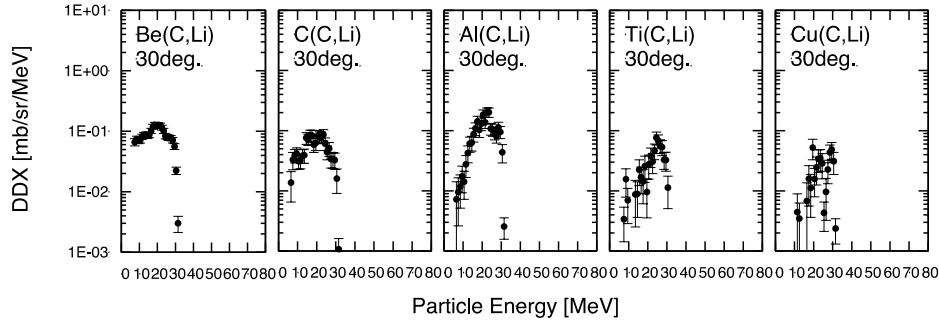

# Activities at Tokyo Institute of Technology (Tokyo Tech)

## Igashira Group

# Capture Cross Sections and Gamma-ray Spectra in the keV Region

---

Nuclide	$E_n = 15 - 100 \text{ keV}$	$E_n = 550 \text{ keV}$
Pd-104	Measured in 2011	2012/7
105	As above	2012/6
106	As above	2012/7
108	As above	2012/10
110	As above	Not yet
Ba-138	2012/12	Not yet

---

# Experimental setup

3-MV Pelletron accelerator  
Pulsed proton beam

Repetition rate : 4 MHz

Beam width : 1.5 ns

Average current : 10  $\mu\text{A}$

Neutron source :  ${}^7\text{Li}(p,n){}^7\text{Be}$

Flight path length :

12 cm for 15-100 keV neutrons

20 cm for 550 keV neutrons

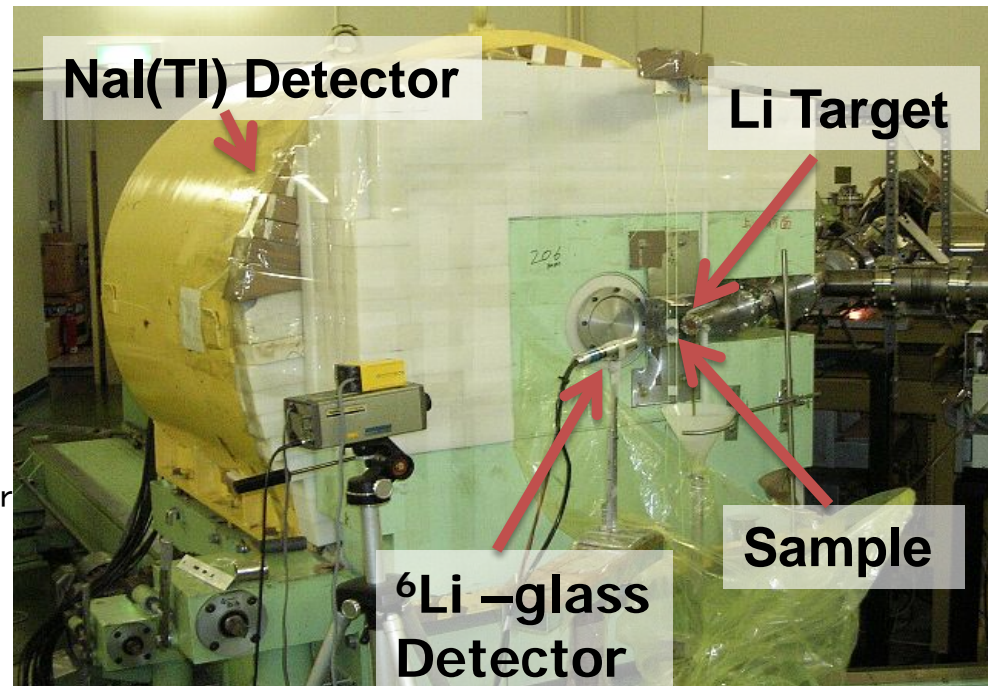
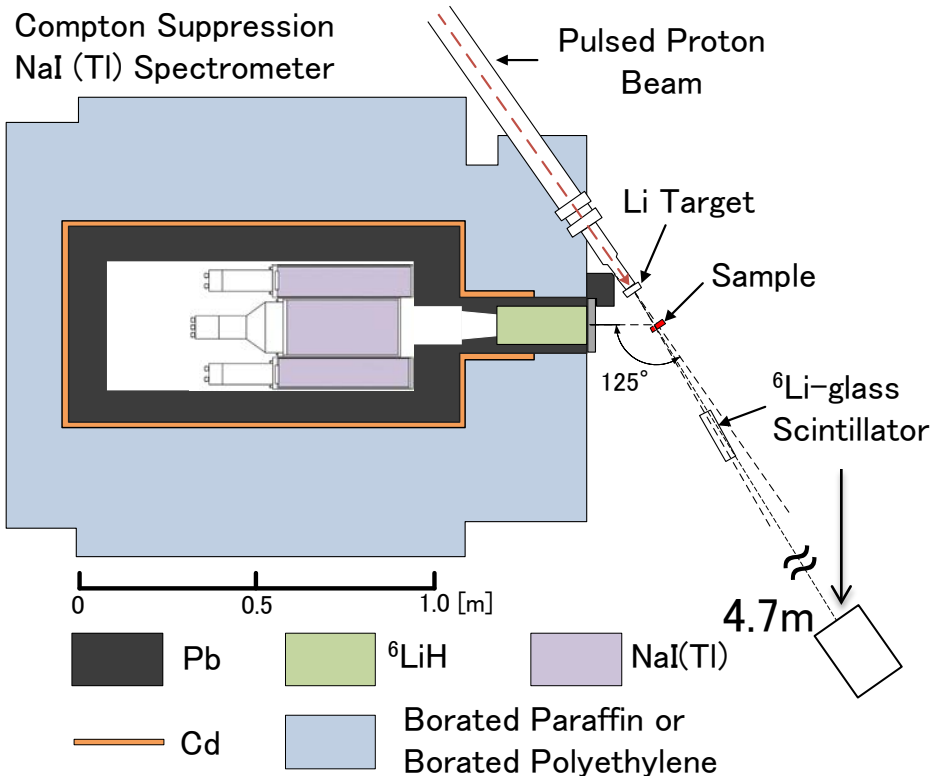

NaI (TI) Spectrometer

➤ Two Dimensional Data: TOF x PH

# Capture Cross Sections of $^{106}\text{Pd}$

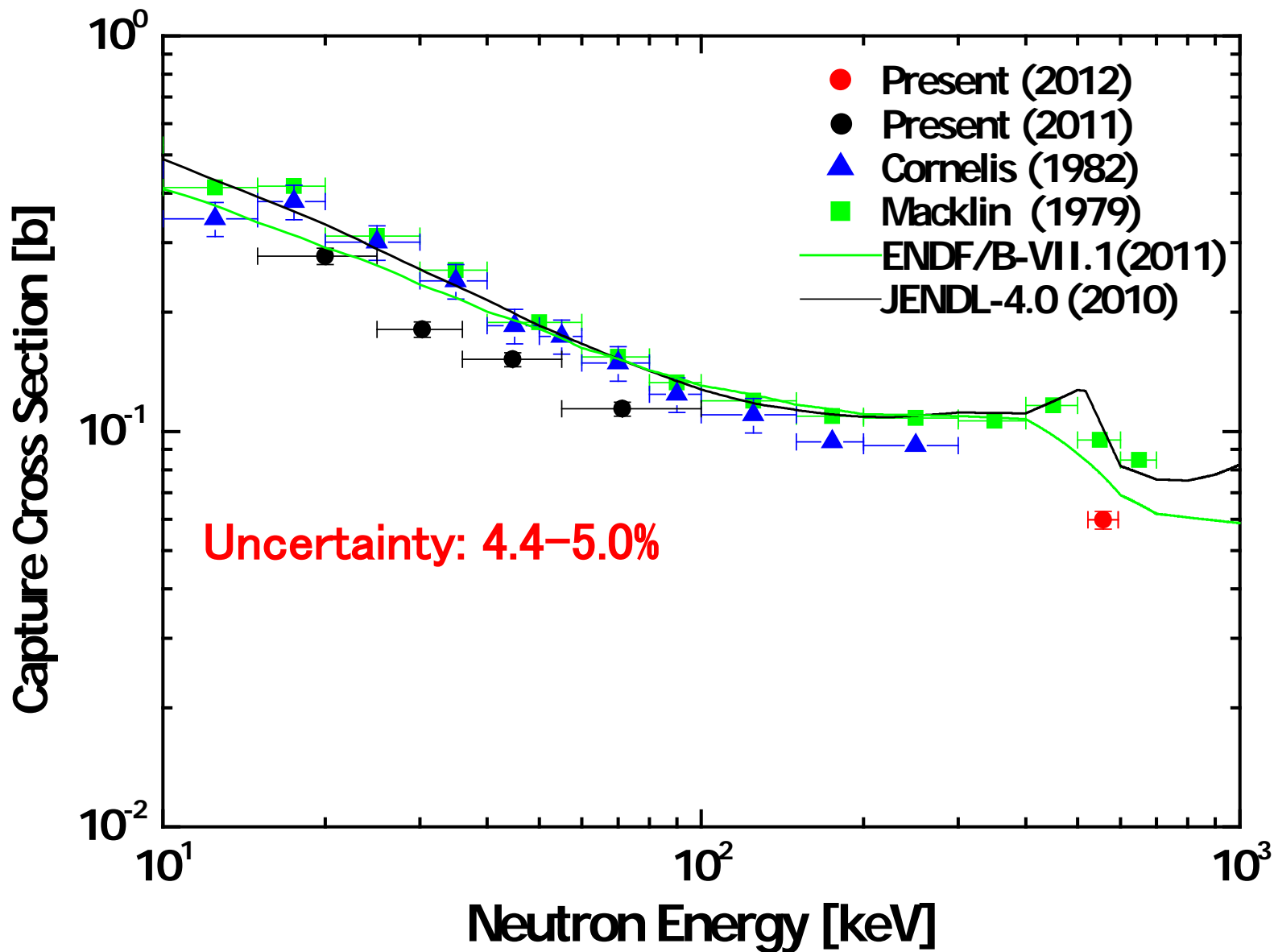

# Capture Gamma-ray Spectra of $^{104}\text{Pd}$

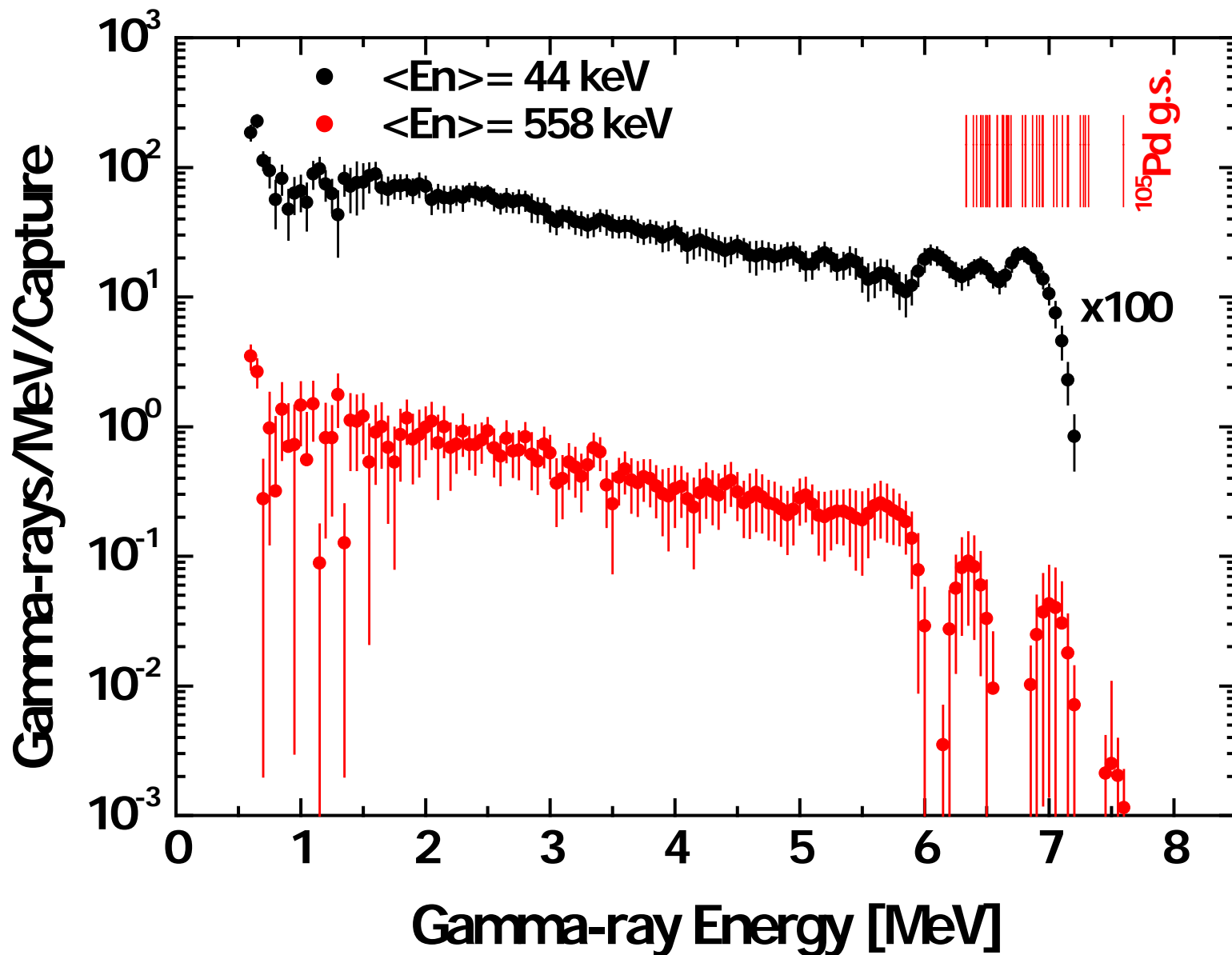

# Activities at Kyoto University

KURRI Group

# Neutron capture cross section measurements for Se-74, 76, 77

Motivation : A systematic measurement of neutron capture cross sections of stable Se isotopes were performed in order to improve the evaluated cross section data of Se-79 which is one of the most important LLFP nuclei.

Neutron Source : **Electron Linear Accelerator** + Ta Target, Flight path:12.7 m

Detector : **Total absorption type BGO detectors**

Energy region: 0.01 eV~20 keV

## Results(Se-74)

H. Yashima *et al.*

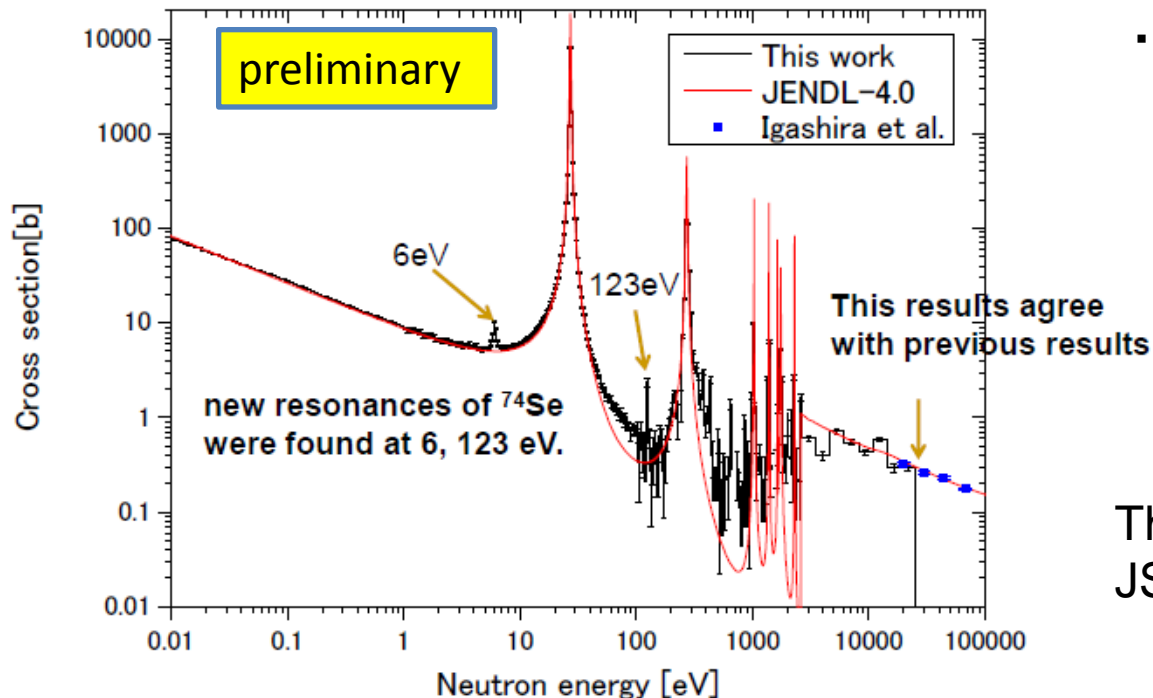

• Sample

Chemical form : Se

Net weight : 580~720 mg

Isotopic purity : >98 %

Shape : 16 mm $\phi$

This work was supported by  
JSPS KAKENHI (22226016).

# Measurements of neutron cross section for Cr, Y, and Tb at 197 MeV

S. Sekimoto *et al.*

Experiment @RCNP

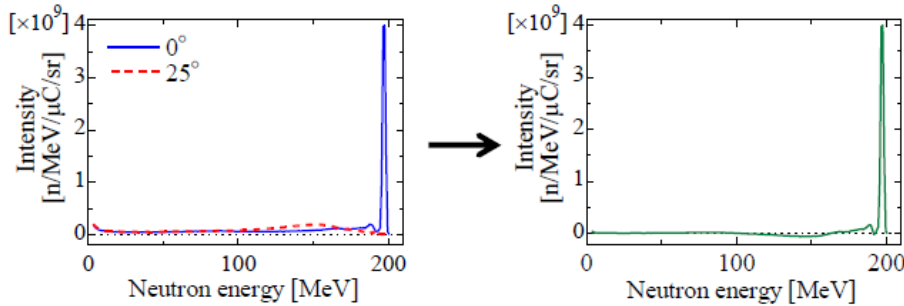

Correcting contribution of the low energy tail.

**The boundary energy,**  
where the calculation codes are  
replaced in the current JENDL-HE,  
**may shift to a new energy.**

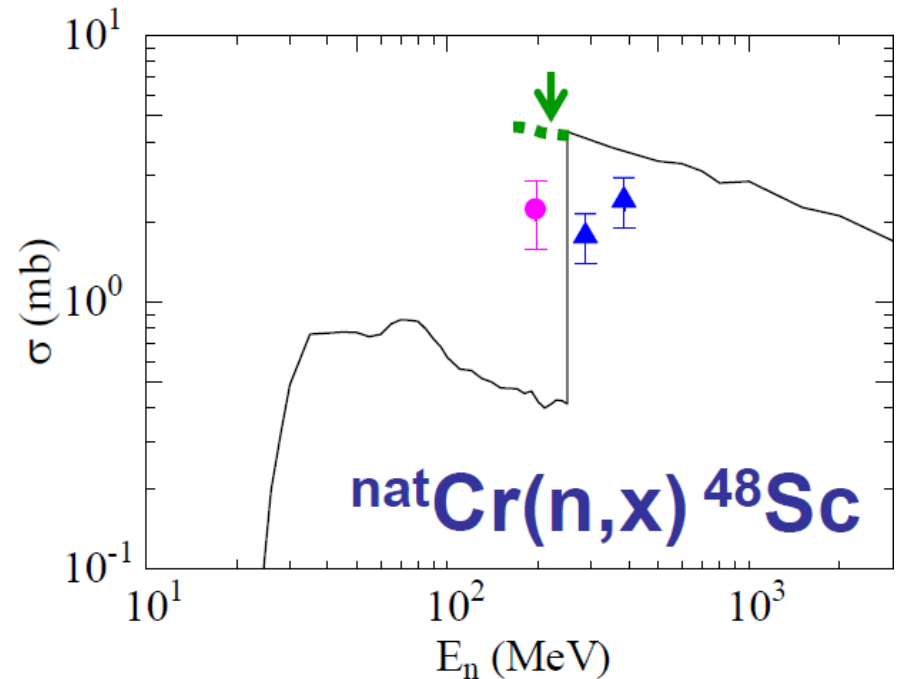
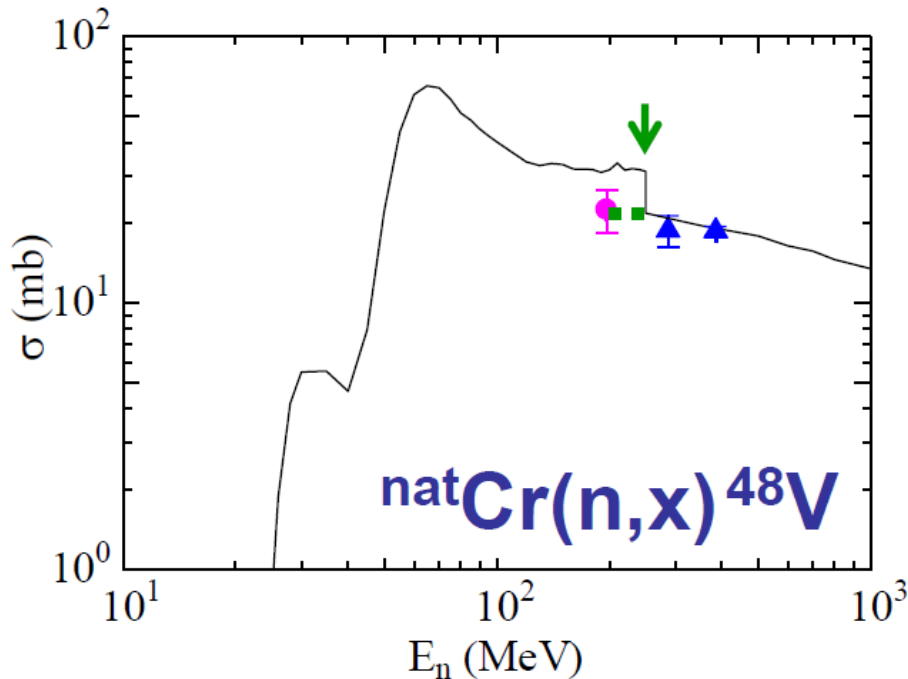

● This work (197 MeV), ▲ Previous work (287, 386 MeV) — JENDL-HE

# Activities at Osaka University

Murata Group

# Benchmark Experiment with A Slab System for Large-angle Scattering Reaction Cross Section

○ Last year, using a beam neutron source at 80 deg. line of **FNS facility, JAEA**, shown in Fig. 1, **niobium foils set in a stainless steel assembly** were irradiated as in Fig. 2 to validate large-angle scattering reaction cross sections. Figure 3 shows the obtained C/E of niobium reaction rates at positions in Fig. 2.

○ Detailed PTRAC analysis was carried out and it was confirmed that large-angle scattering could be most emphasized at position ② and contribution of leakage neutrons through the collimator of the neutron source could not be ignored as shown in Table 1.

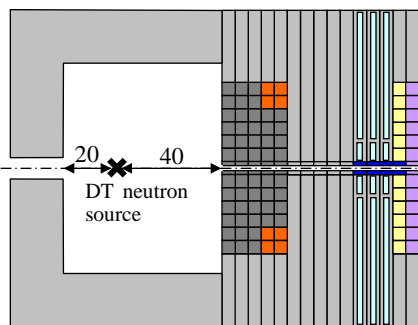

Fig. 1 FNS 80 deg. beam neutron source.

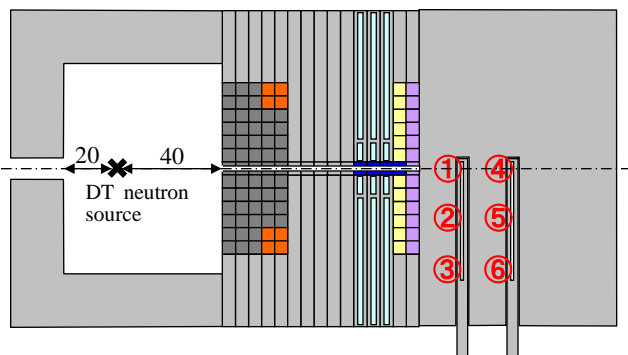

Fig. 2 Stainless assembly attached to the beam neutron source of Fig. 1. Niobium foils were set at positions ① ~ ⑥.

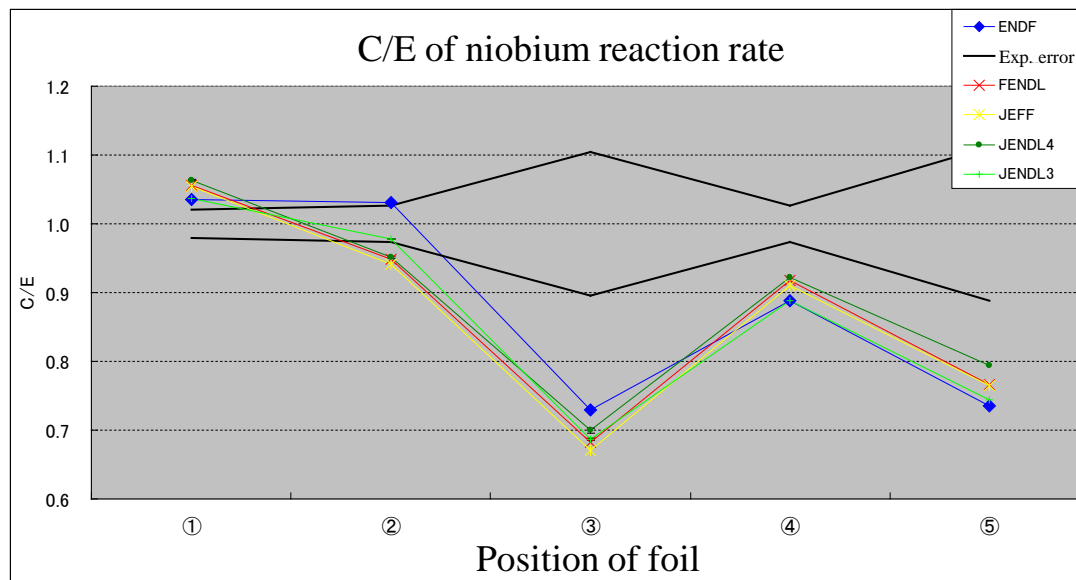

Fig. 3 Comparison of **Nb foil activation reaction rate** between experiment and calculation (C/E) at positions in Fig. 2.

Table 1. Contribution of beam neutron to the reaction rate. By flagging an cell positioned at the exit of the beam neutron, reaction rate due to beam neutrons was calculated.

Tally Position	[A] Reaction rate (Reaction*1e-24/source)	[B] Reaction rate due to beam neutrons (Reaction*1e-24/source)	Beam neutron contribution [B]/[A]	FSD
①	1.57E-07	1.50E-07	95%	0.0003
②	5.95E-10	3.73E-10	63%	0.0007
③	4.65E-11	2.00E-11	43%	0.0031
④	2.67E-09	2.53E-09	95%	0.0003
⑤	1.28E-10	1.07E-10	84%	0.0006
⑥	1.04E-11	6.73E-12	65%	0.0025

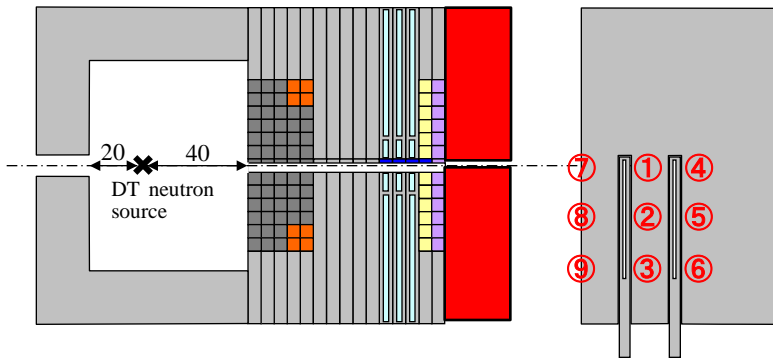

Fig. 4 New experimental assembly in which a copper shield (in red) was positioned between the beam collimator and the stainless assembly. Niobium foils were set at positions ① ~ ⑨.

○From Table 1, contribution of leakage neutrons passing through the collimator shield is substantially large at positions ② and ③.

○To avoid the contribution, supplementary copper shield (in red) was placed. And in addition foils at ⑦ ~ ⑨ were added, because from the PTRAC analysis the positions just after the collimator would give the large-angle scattering effect most remarkably.

○At present, the precise data processing is being carried out and numerical analysis with MCNP5 is underway.

# Activities at Konan University

## Utsunomiya Group

# Progress Report in 2012

H. Utsunomiya, Konan Univ.

## Papers published

1. Total and partial photoneutron cross sections for Pb isotopes, T. Kondo, H. Utsunomiya *et al.*, *Physical Review C* 86, 014316 (2012).
2. Separation of Pygmy Dipole and M1 resonance in  $^{90}\text{Zr}$  by a High-Resolution Inelastic Proton Scattering Near  $0^\circ$ , C. Iwamoto, H. Utsunomiya *et al.*, *Physical Review Letters* 108, 262501 (2012)

# Progress #1

1. Construction of a new experimental hutch GACKO for  $\gamma$ -ray experiments at the NewSUBARU synchrotron radiation facility

NewSUBARU

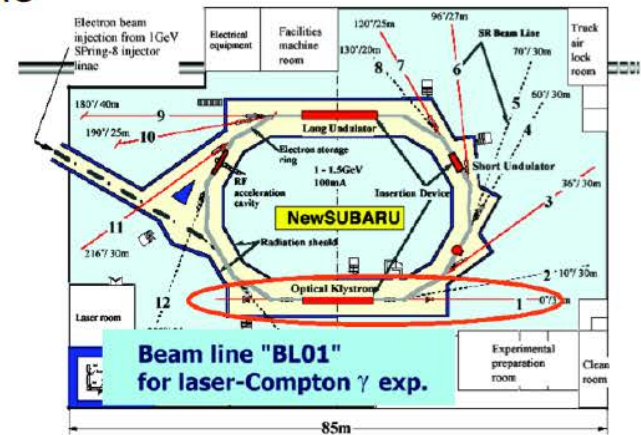

GACKO



# Progress #2

2. Seven experiments were carried out at NewSUBARU-GACKO during Dec. 2012 - Feb. 2013.

Jan. 2013

International collaboration for photoneutron cross sections measurements for  $^{162,163}\text{Dy}$ ,  $^{146,148}\text{Nd}$ , and  $^{150,152}\text{Sm}$ .

*Konan University, RCNP Osaka University, University of Oslo, Bucharest IFIN-HH, Texas A&M University*

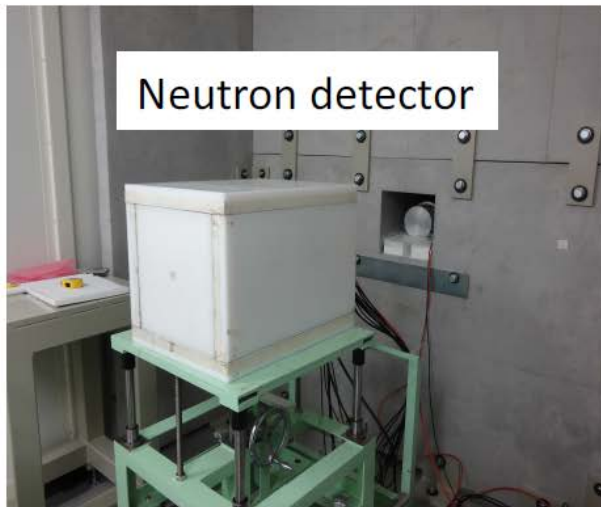

# Plans in the near future

## Photoneutron cross section measurements at NewSUBARU-GACKO

1. PDR in  $^9\text{Be}$  May 2013
2. 1<sup>st</sup> excited state in  $^9\text{Be}$  June 2013
3. 2<sup>nd</sup> International collaboration July 2013

Systematic measurements for Nd and Sm isotopes

*Konan University, RCNP Osaka University, University of Oslo,  
Bucharest IFIN-HH, Texas A&M University*

4. 3<sup>rd</sup> International collaboration  
Systematic measurement for Ni isotopes

## Meetings

Workshop "Towards Technical Design Reports (TDR) of experiments with brilliant gamma-ray beams at ELI-NP", June 25th - 26th, 2013

# Activities at Kyushu University

## Watanabe Group



# Systematic Measurement of Double-Differential Neutron Yields From Thick Target Irradiated by Deuterons Below 10 MeV



Energy Engineering Physics Laboratory  
Department of Advanced Energy Engineering Science  
Kyushu University

*In collaboration with Ishibashi Group in the Faculty of Engineering, Kyushu University*

# Experiment @KUTL

- Thick target yield (TTY) data for deuteron accelerator-based neutron sources
- Kyushu University Tandem Laboratory (KUTL)
  - Deuteron energies : 5 and 9 MeV
- Detector system
  - NE213 scintillator (50.4 mm thick and 50.4 mm in diameter)
  - Unfolding method with FORIST code
- Target
  - Al and C with stopping length in FY2012
- Measurement Angles
  - 0, 15, 30, 45, 60, 75, 90, 120, 140 degrees

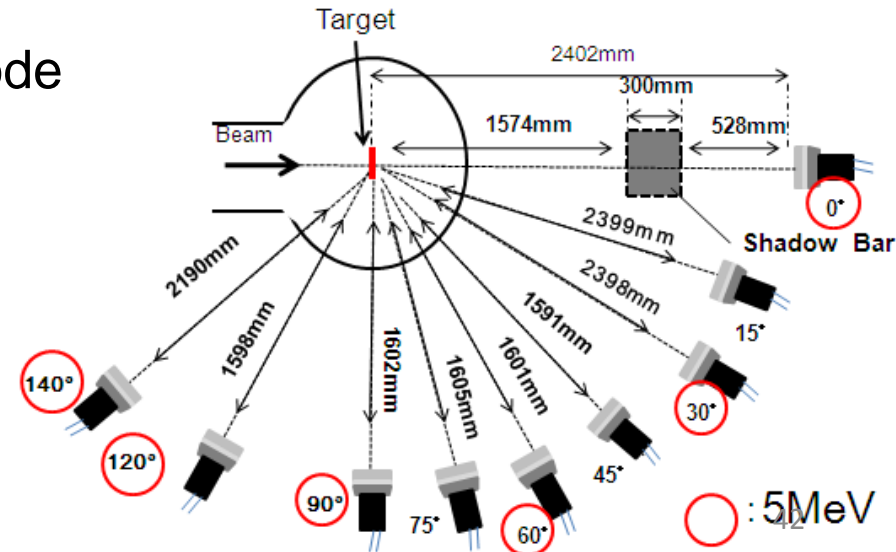

# Result

- Experimental double-differential thick target neutron yields from **Carbon at 5 and 9 MeV**
- Comparison of the measurement with PHITS calculations using the NASA formula or the Shen formula for total reaction cross sections

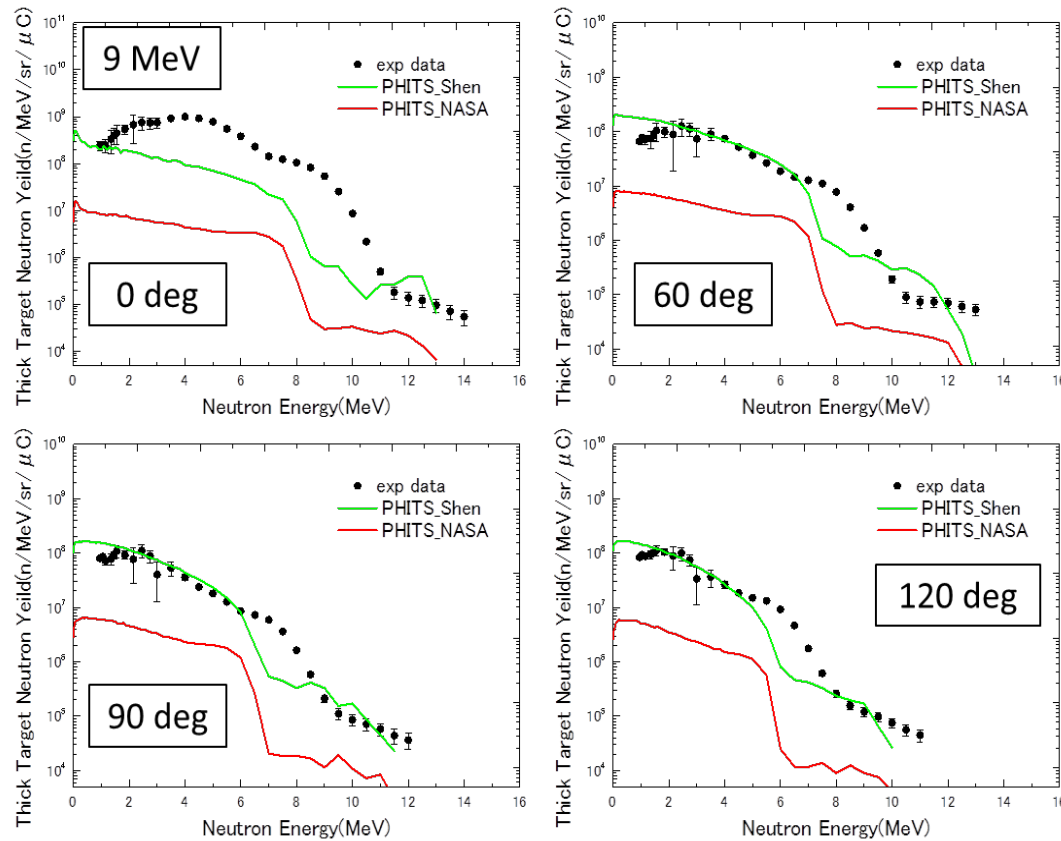

The PHITS calculation using the Shen formula reproduces satisfactorily well the experimental data, compared with that using the NASA formula

# Activities at Kyushu University

Department of Applied Quantum Physics and Nuclear  
Engineering

Ishibashi and Uozumi Group

# Neutron Production DDX from Heavy-Ion Interactions @ NIRS-HIMAC

- Kyushu U., JAEA, Hiroshima U., KEK, NIRS, KAERI
- Systematic cross-section data for elements constituting a human body's tissue bombarded with heavy-ion beams
- HIMAC PH2 beam line
- Beam: 100 MeV/u C
- Target: C, AlN, Al<sub>2</sub>O<sub>3</sub>, Al
- Detection: NE213 (2 sizes) + TOF
- Direction: 0°, 15°, 30°, 45°, 60°, 75°, 90°
- Data obtained below 1 MeV of E<sub>n</sub>
- PHITS reproduces experimental data especially above tens MeV region

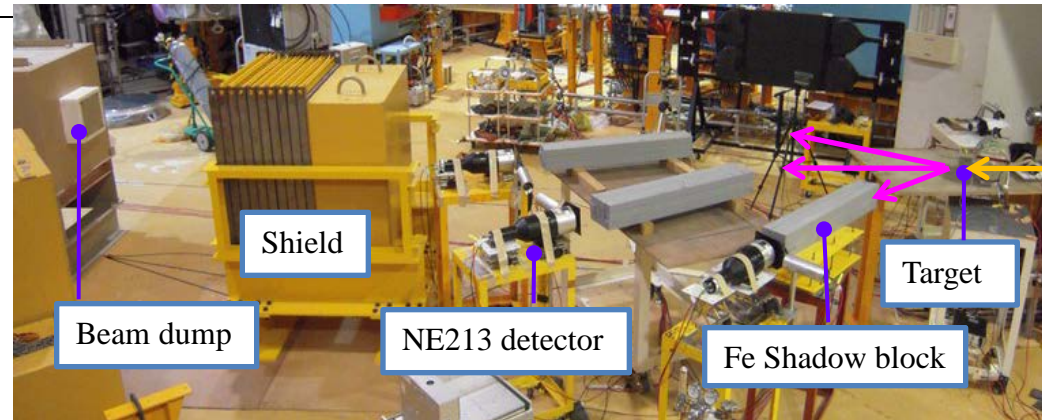

Experimental setup at HIMAC

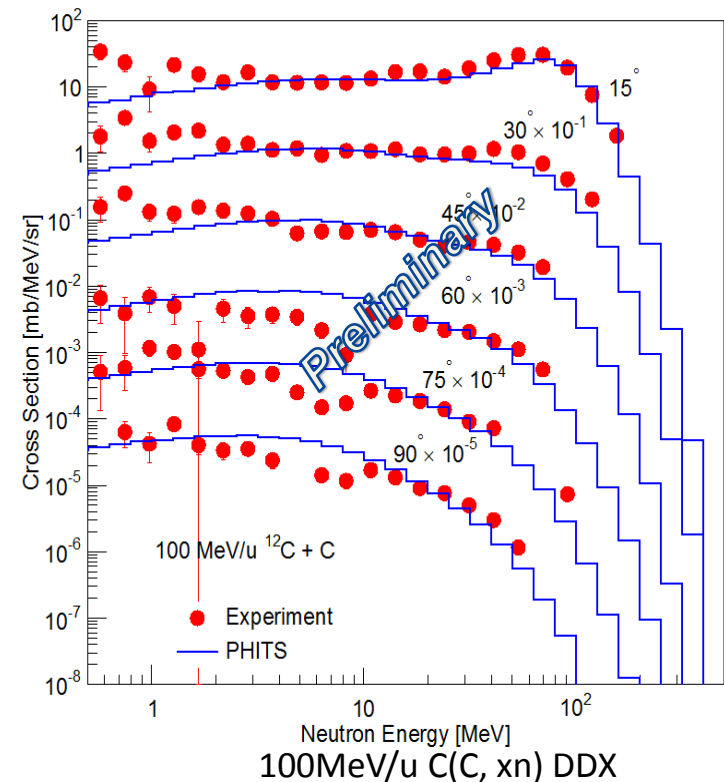

Thank you very much for your attention!