

The ALTO project at IPN Orsay

Production of fission fragments with photofission ISOL type device

First part : deuterons + ISOL device

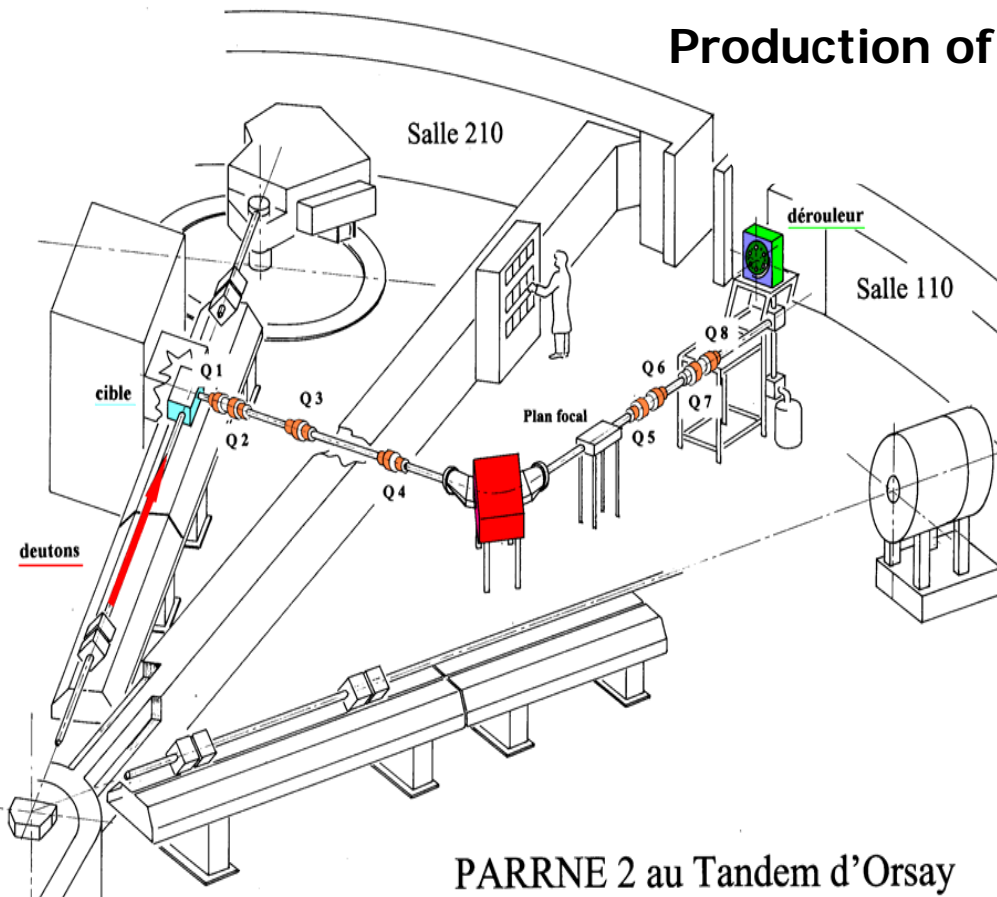

Optimization of the different parameters for the production :
R&D target / ion sources

Study of neutron rich
Nuclei around $N=50$

PARRNE 2 au Tandem d'Orsay

Productions at PARRNe

Production /s/μA

- $5 \cdot 10^6 - 5 \cdot 10^7$
- $10^6 - 5 \cdot 10^6$
- $5 \cdot 10^5 - 10^6$
- $10^5 - 5 \cdot 10^5$
- $5 \cdot 10^4 - 10^5$
- $10^4 - 5 \cdot 10^4$
- $5 \cdot 10^3 - 10^4$
- $10^3 - 5 \cdot 10^3$
- $10^2 - 10^3$
- Stable

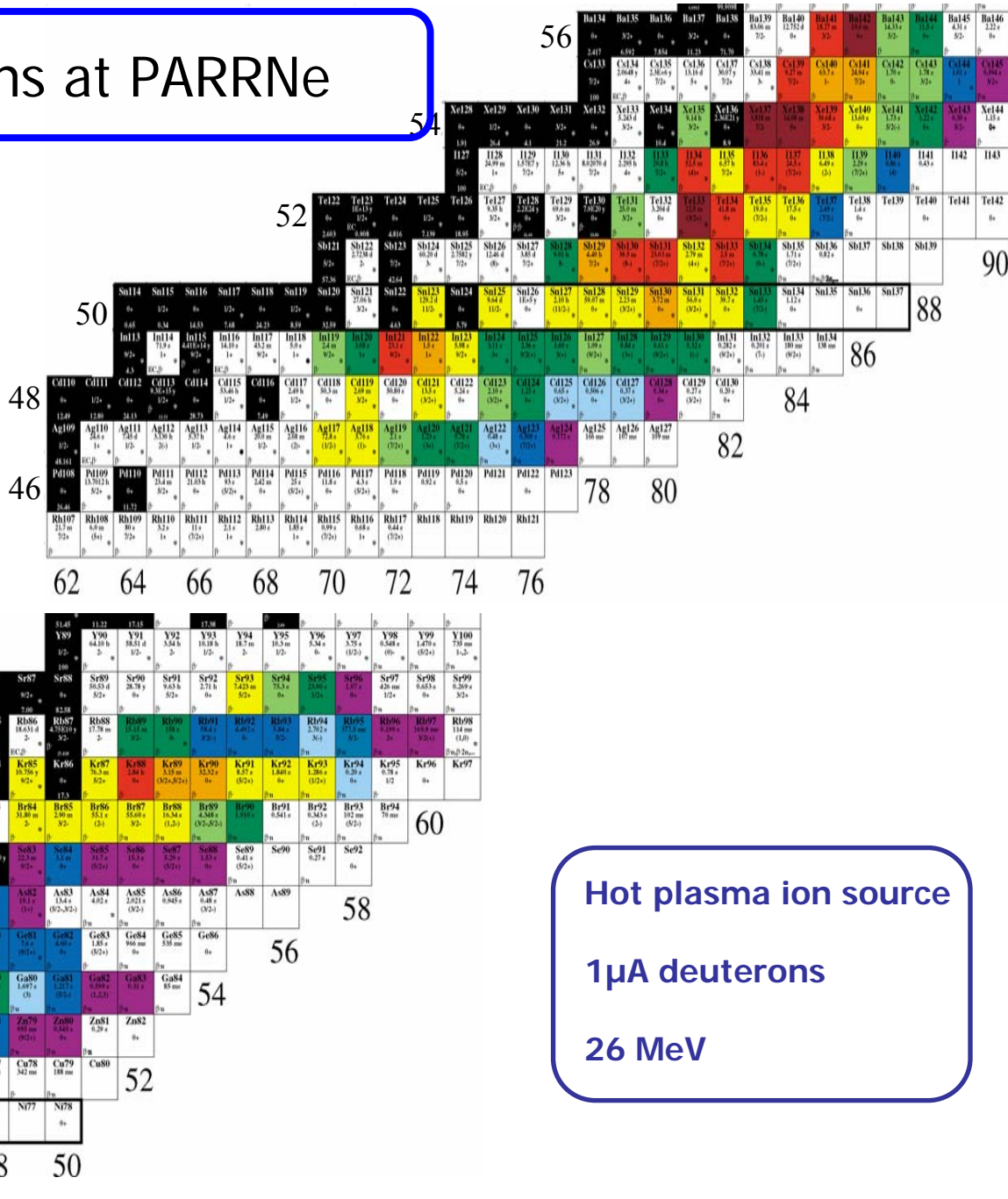

Hot plasma ion source
 1μA deuterons
 26 MeV

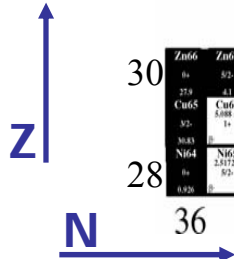
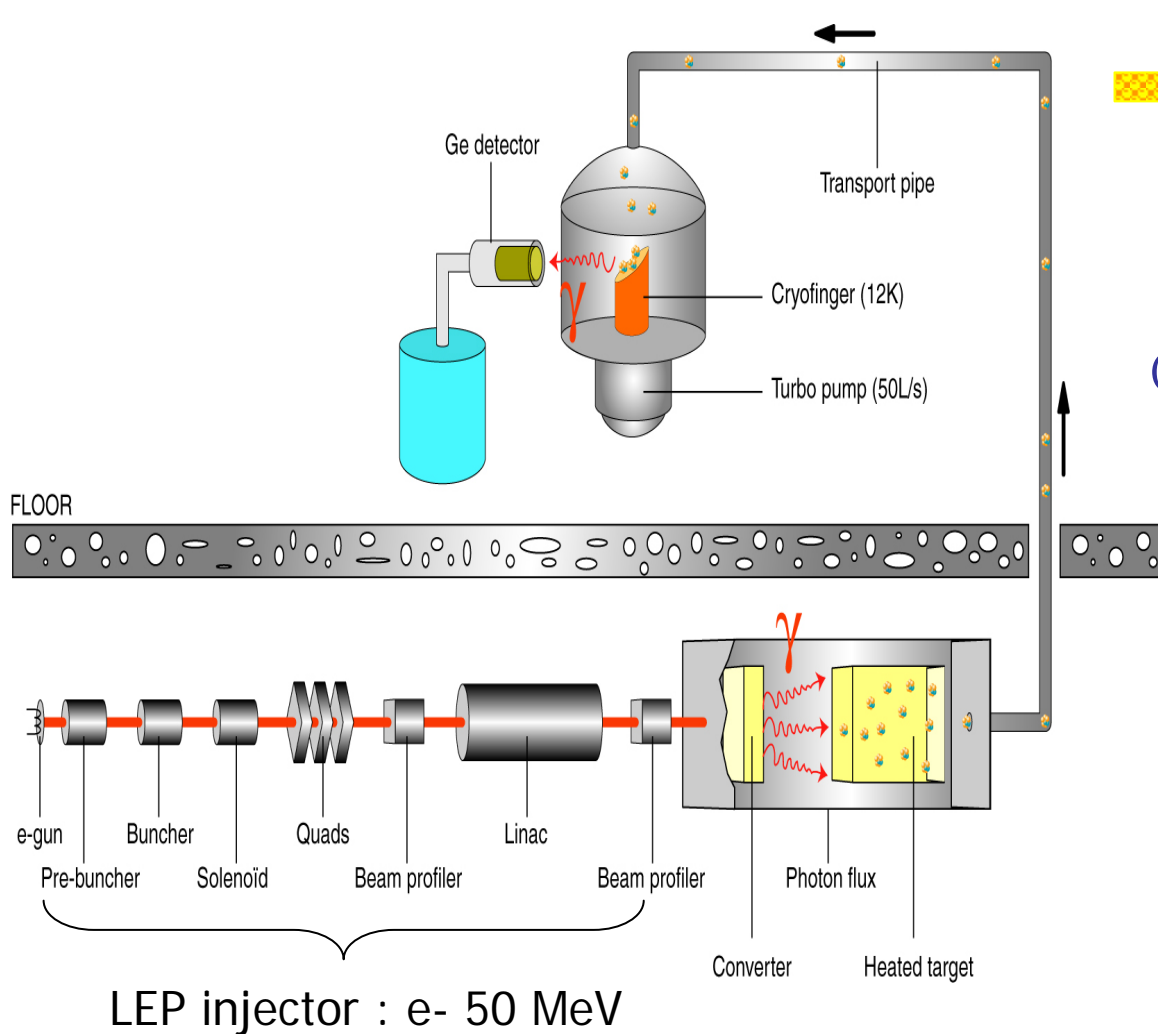
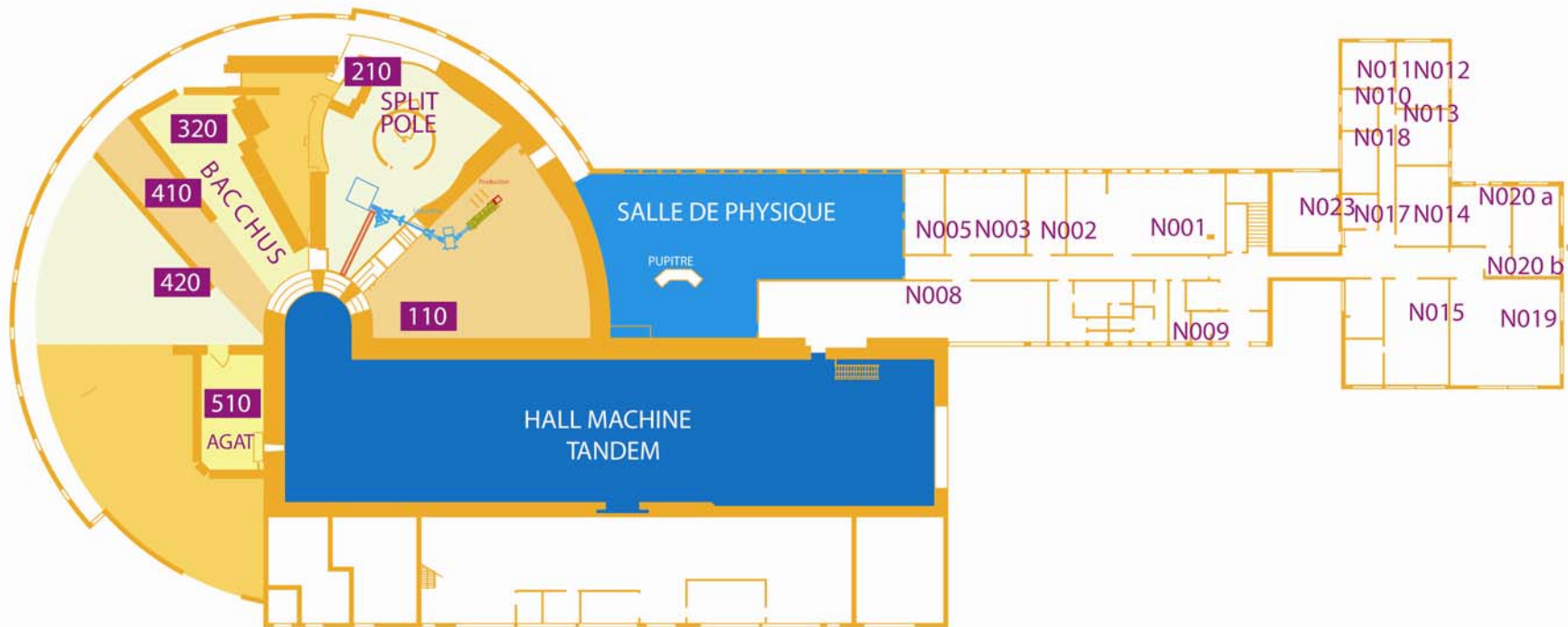

Photo-fission at CERN



Comparison with experiments
 Performed with the same
 Conditions using deuterons
 20, 26, 50, 80 et 130 MeV

Gain v/s PARRNe
 X 10 reaction
 X 10 intensity
 ↓
factor 100



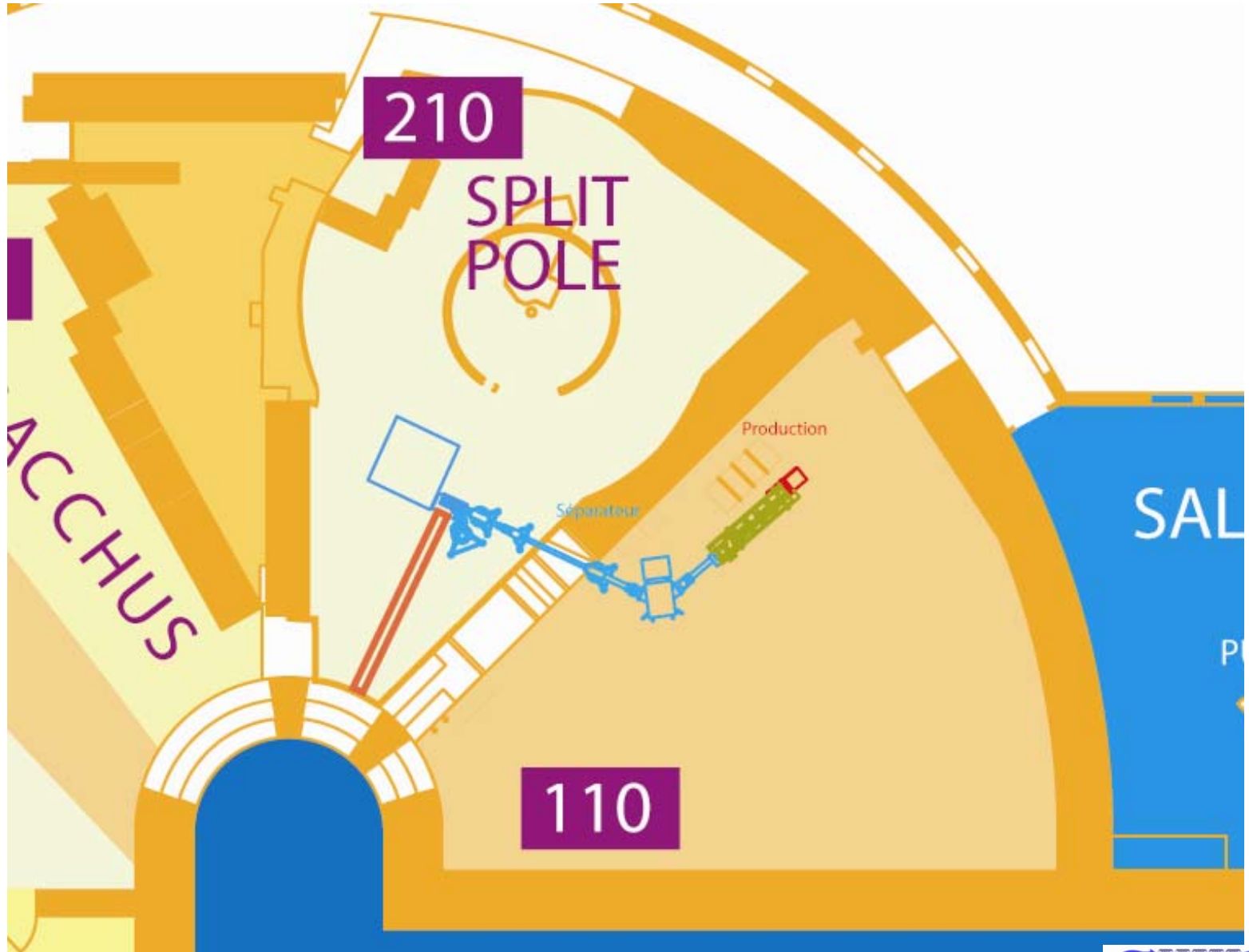

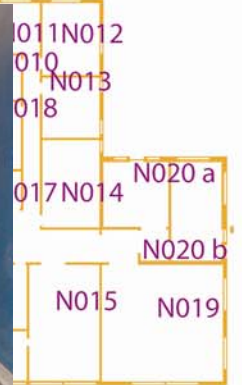
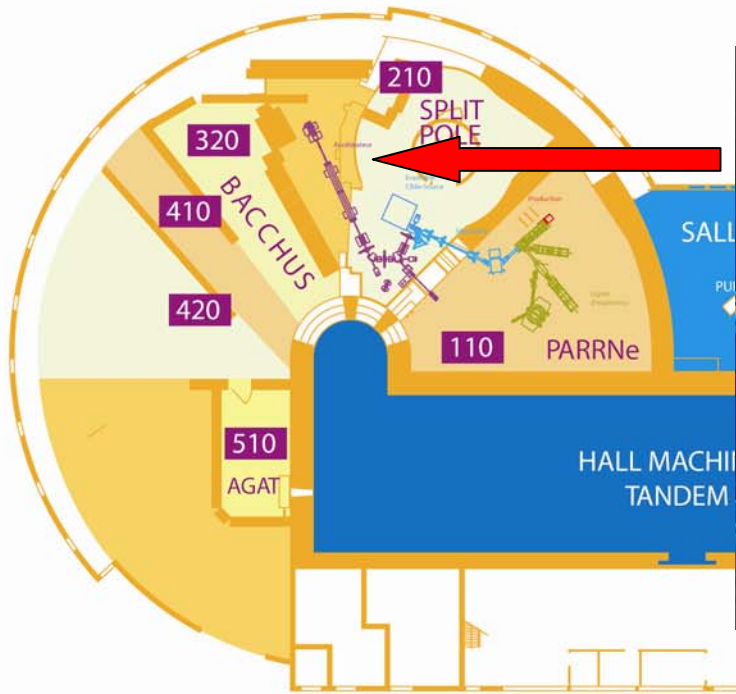

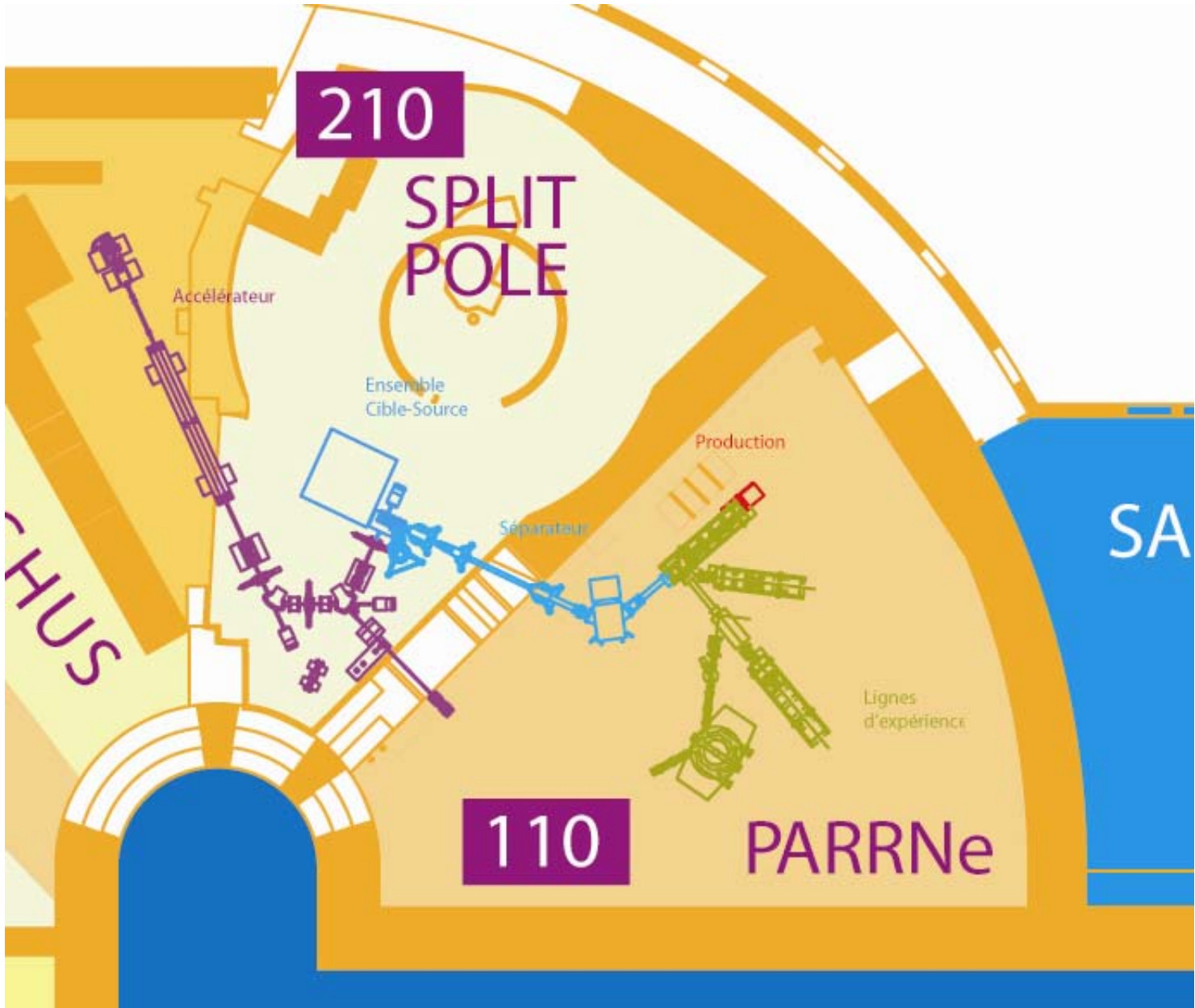

210

SPLIT
POLE

Accélérateur

Ensemble
Cible-Source

Production

Séparateur

Lignes
d'expérience

SA

110

PARRNe

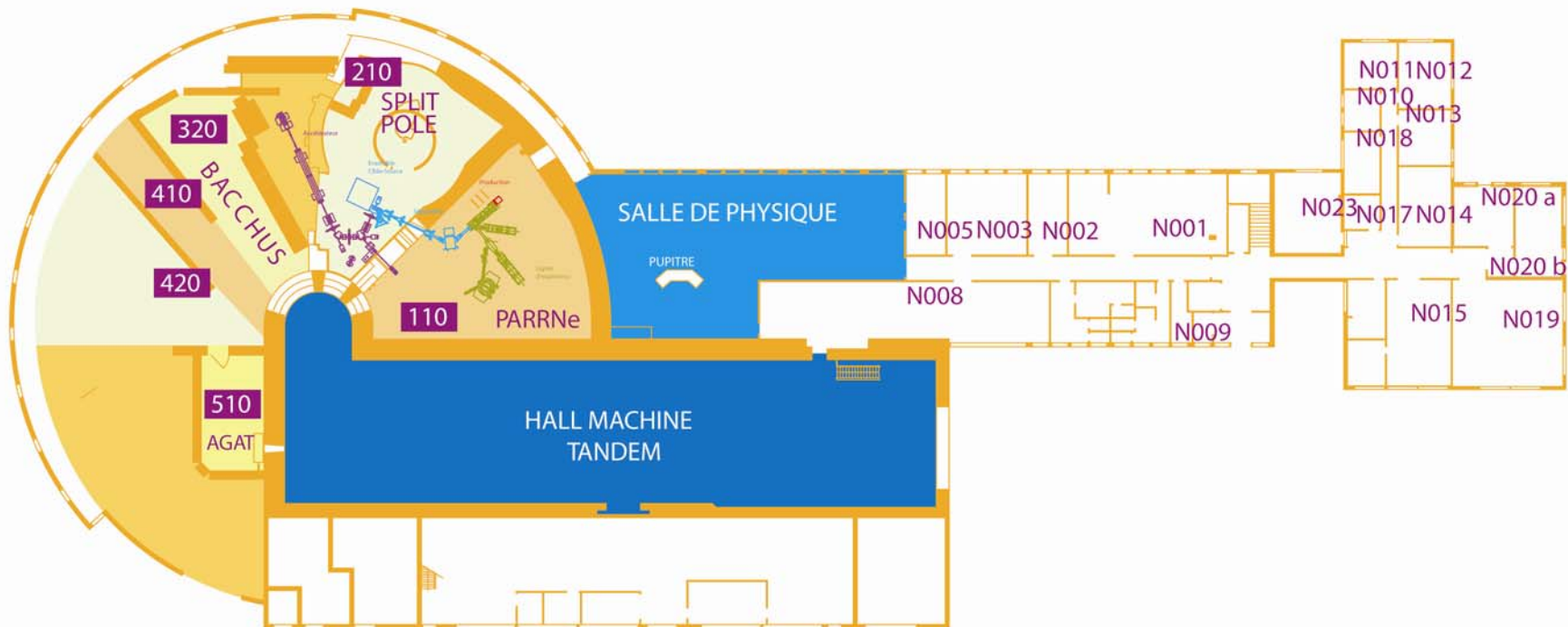

10 μ A, 50 MeV electrons
 factor 100 in comparison with deuterons

10¹¹-4 10¹¹ fissions per second

3 10⁷- 10⁸ ¹³²Sn after separation

~ ISOLDE
 less isobaric
 contaminant

Comparison with ISOLDE

^{132}Sn region

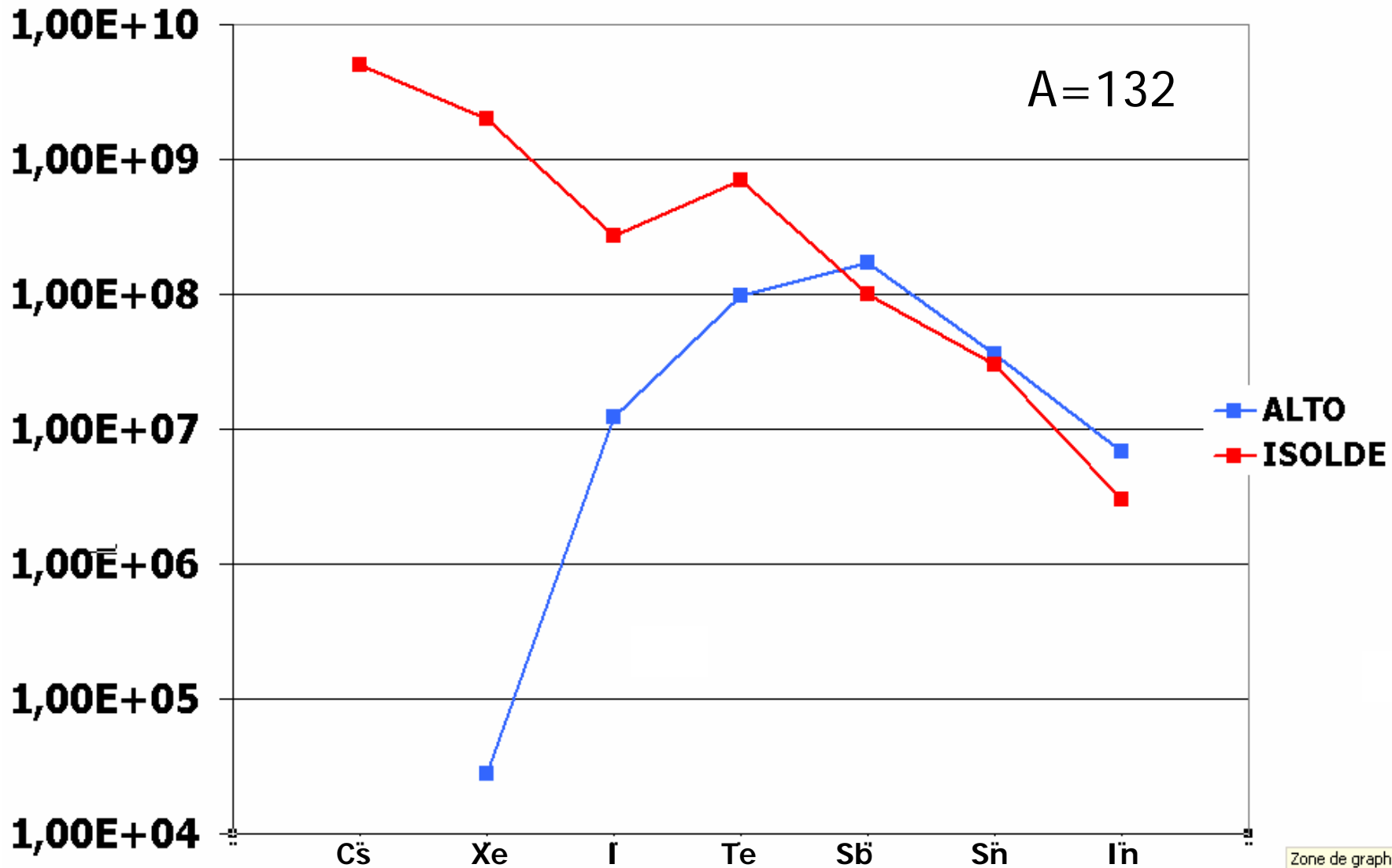

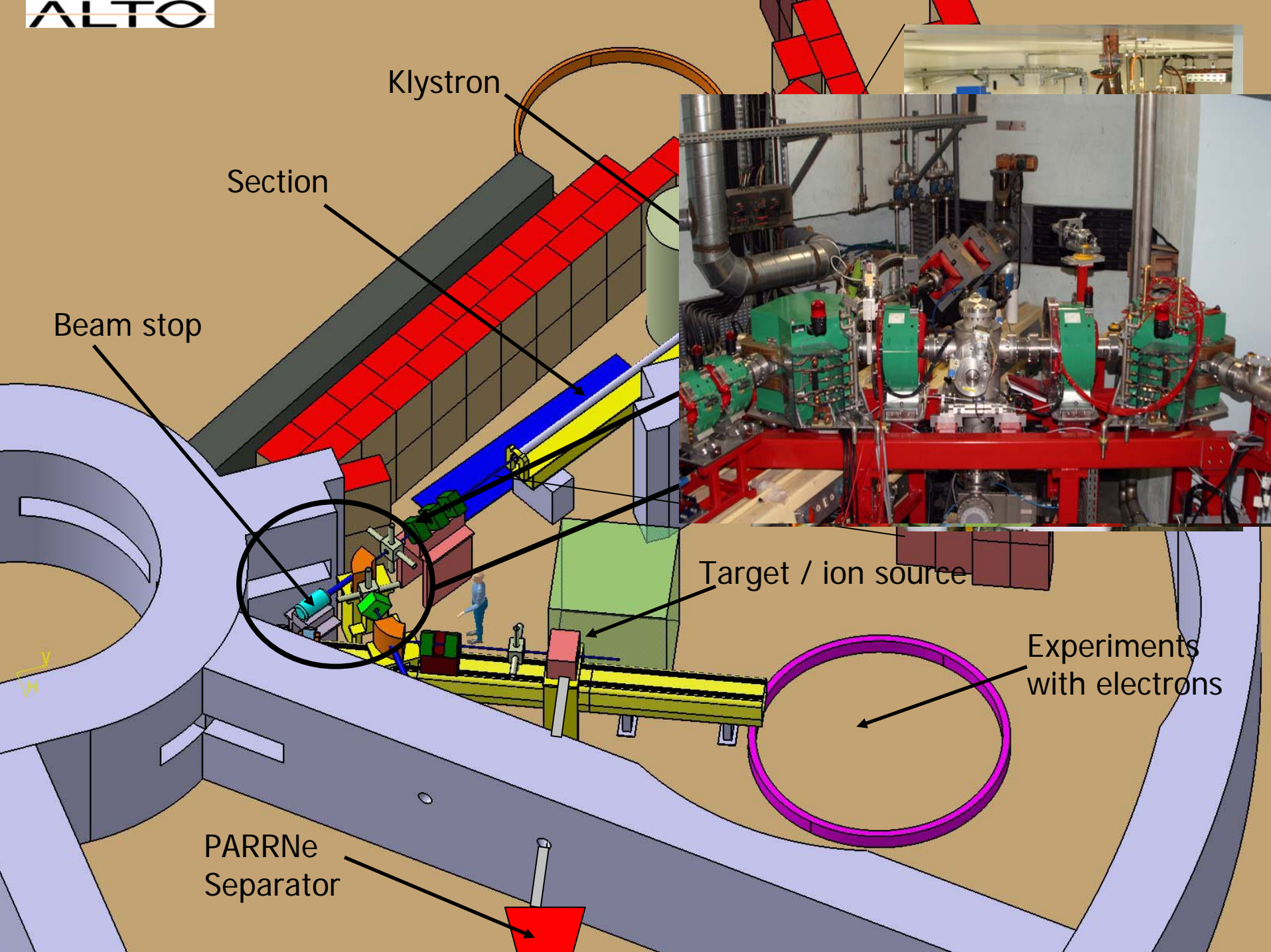

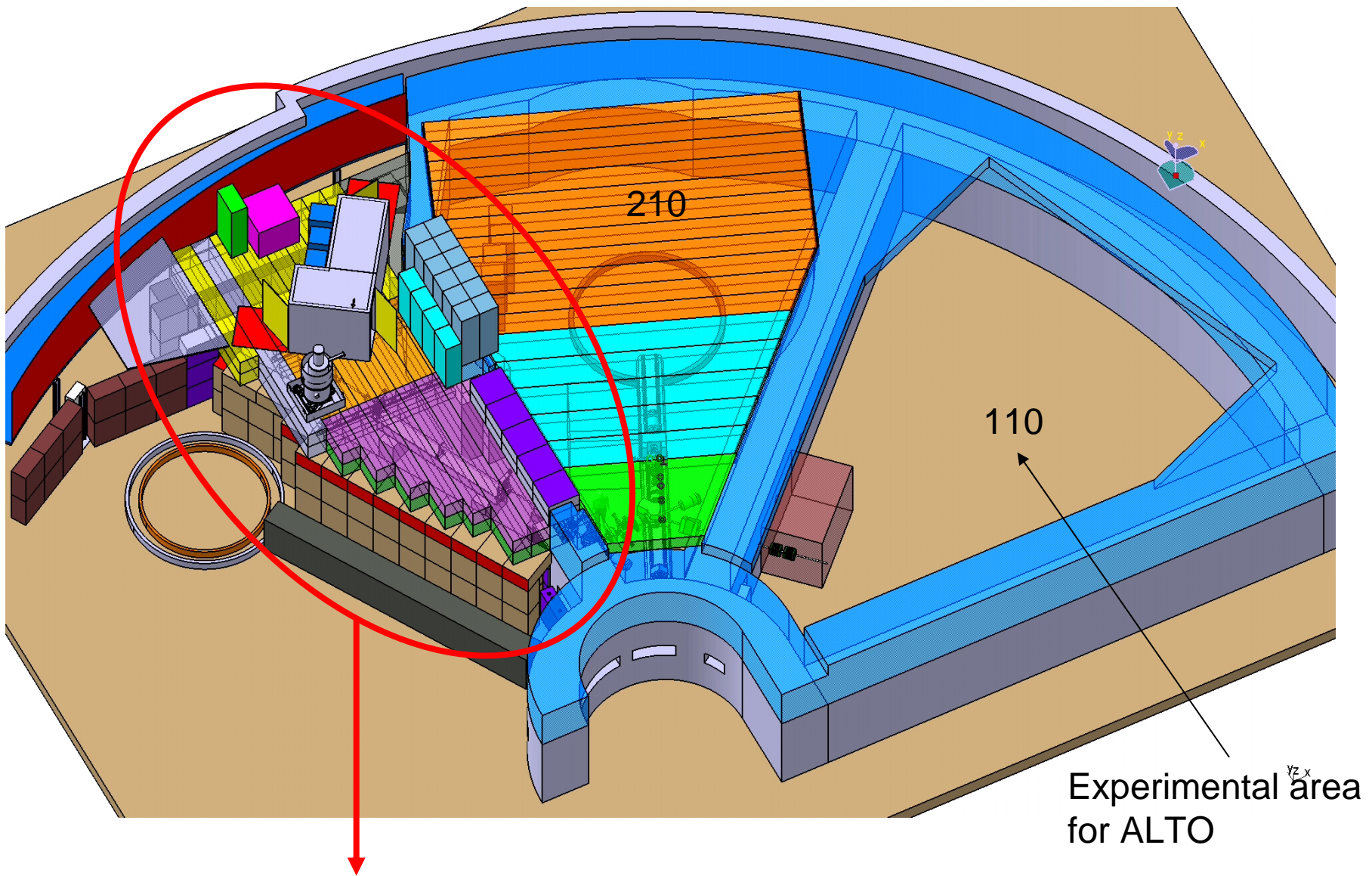

Construction of the bunker : finished 2004
installation of the modulator and klystron : finished 2005
Radioprotection file and measurements : in progress

The fabrication of the target

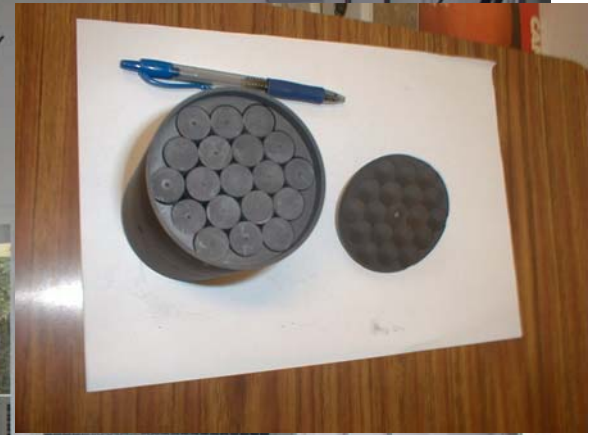

Some ion sources already developed at PARRNe

Plasma

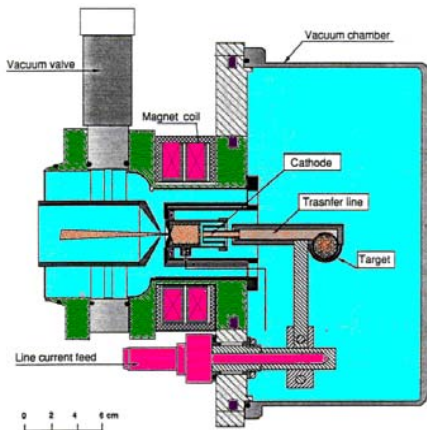

High temperature (1900 °C)

Compact: the target is part of the source high efficiency

well adapted for a large number of elements

Ionisation de surface



Very high efficiency

Dedicated to alkaline and Ga In

Laser source

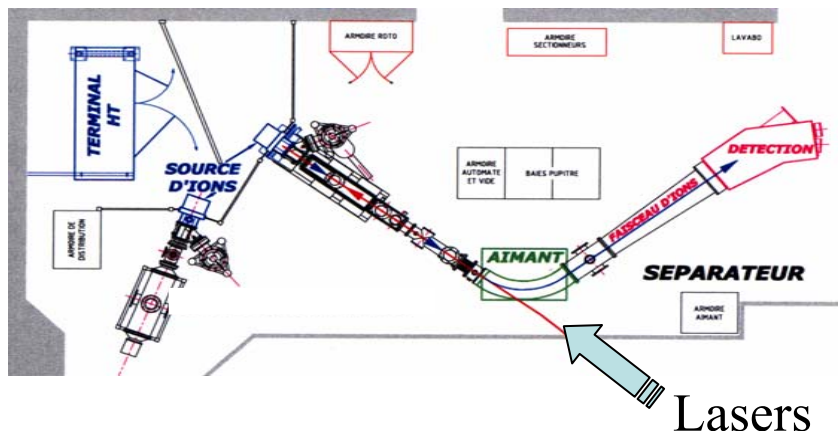

Very selective ion source

High efficiency depending on the rate frequency of the laser

Large number of elements could be ionized

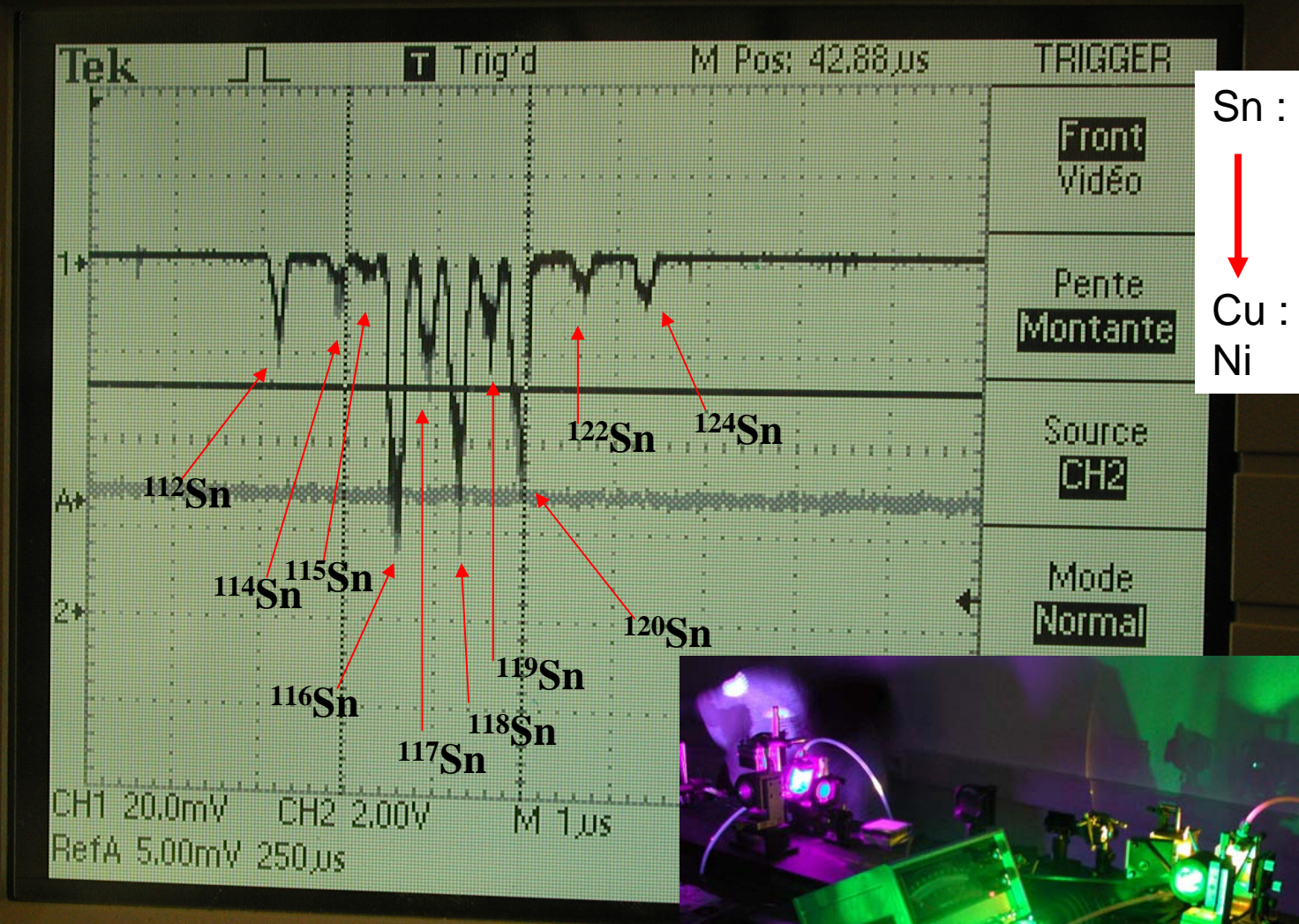

Sn : ok

↓

Cu : ok

Ni

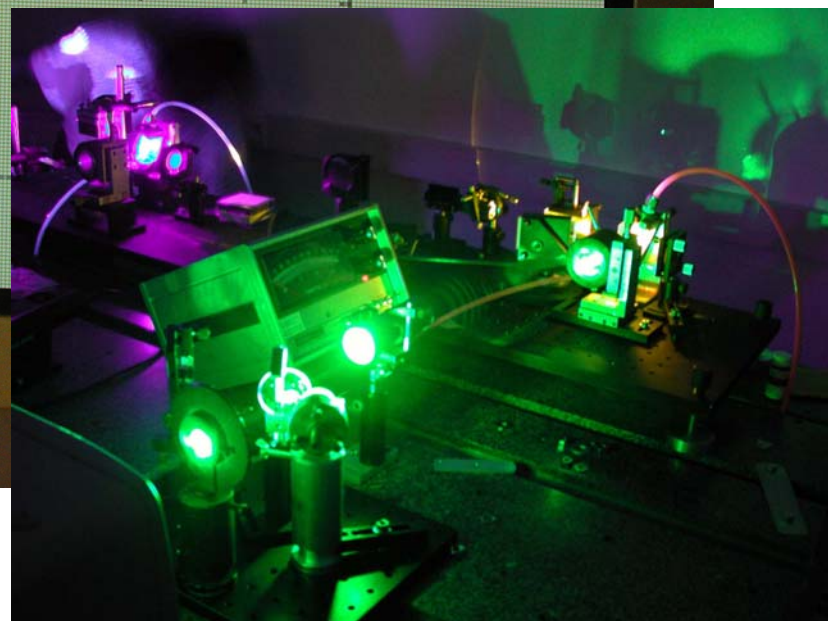

SiHL
Poard

Documents F. Le Blanc et groupe
Cibles sources

An ion guide at ALTO

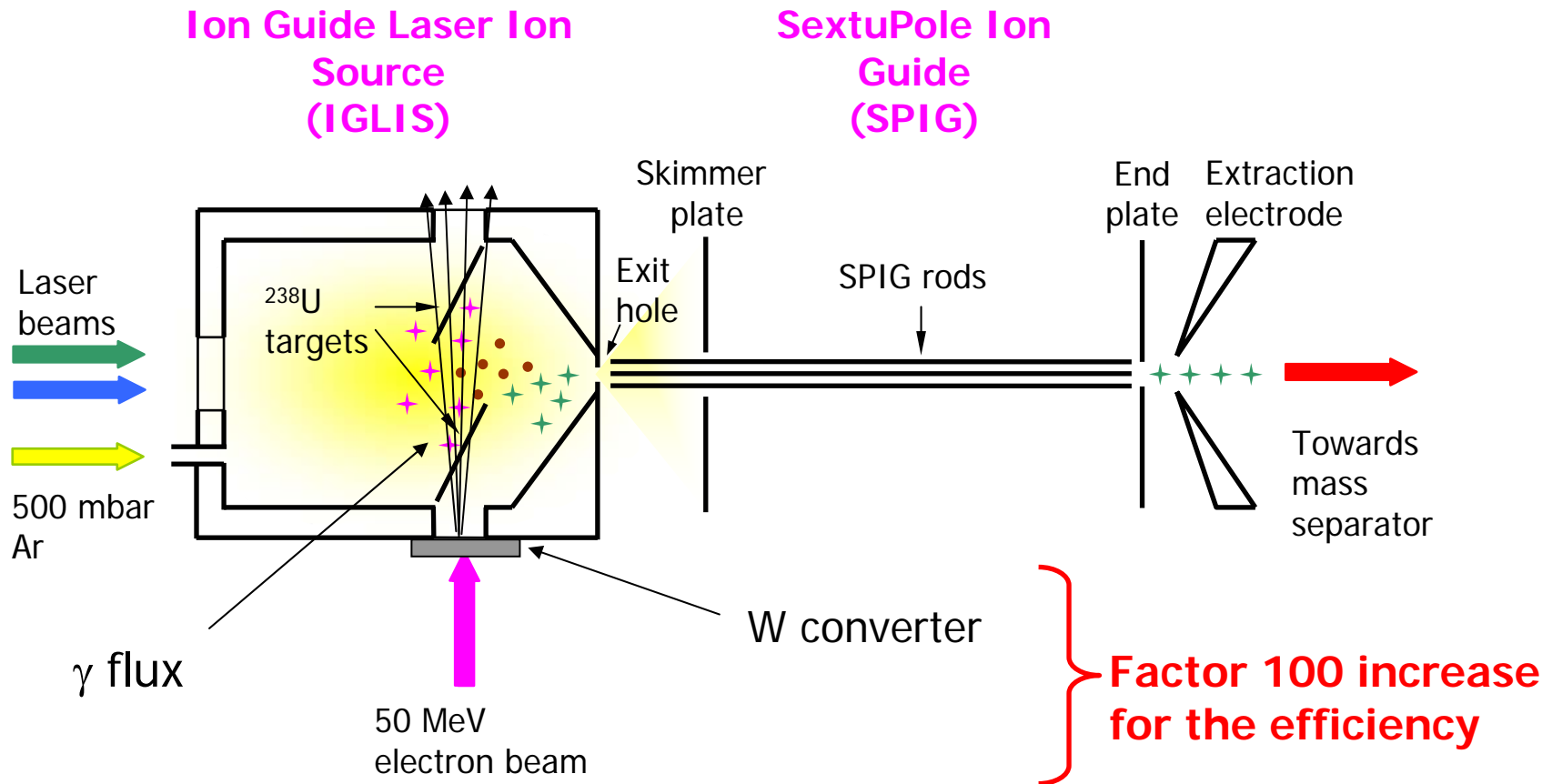

Y. Kudryavtsev et al., NIM B114 350 (1996)
P. Van den Bergh et al., NIM B126 194 (1997)

Design of a laser ion guide at Alto

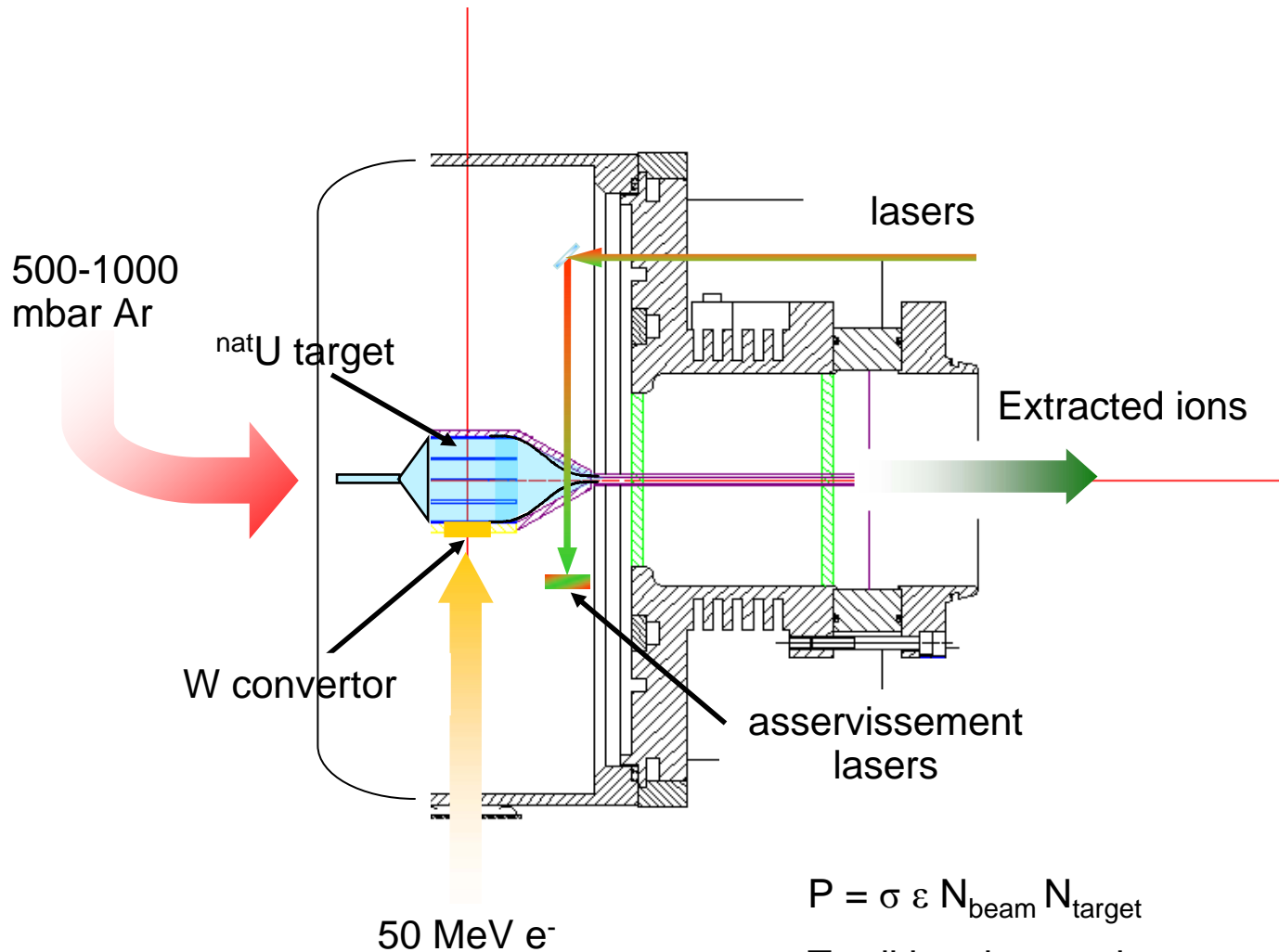

photofission at Alto:
no charged beam inside gas cell !

$$P = \sigma \varepsilon N_{\text{beam}} N_{\text{target}}$$

Traditional target ion source: $\varepsilon = 0$

Ion guide :

$N_{\text{thin target}} \ll N_{\text{thick target}}$ but $\varepsilon > 0$

Design of a laser ion guide at Alto

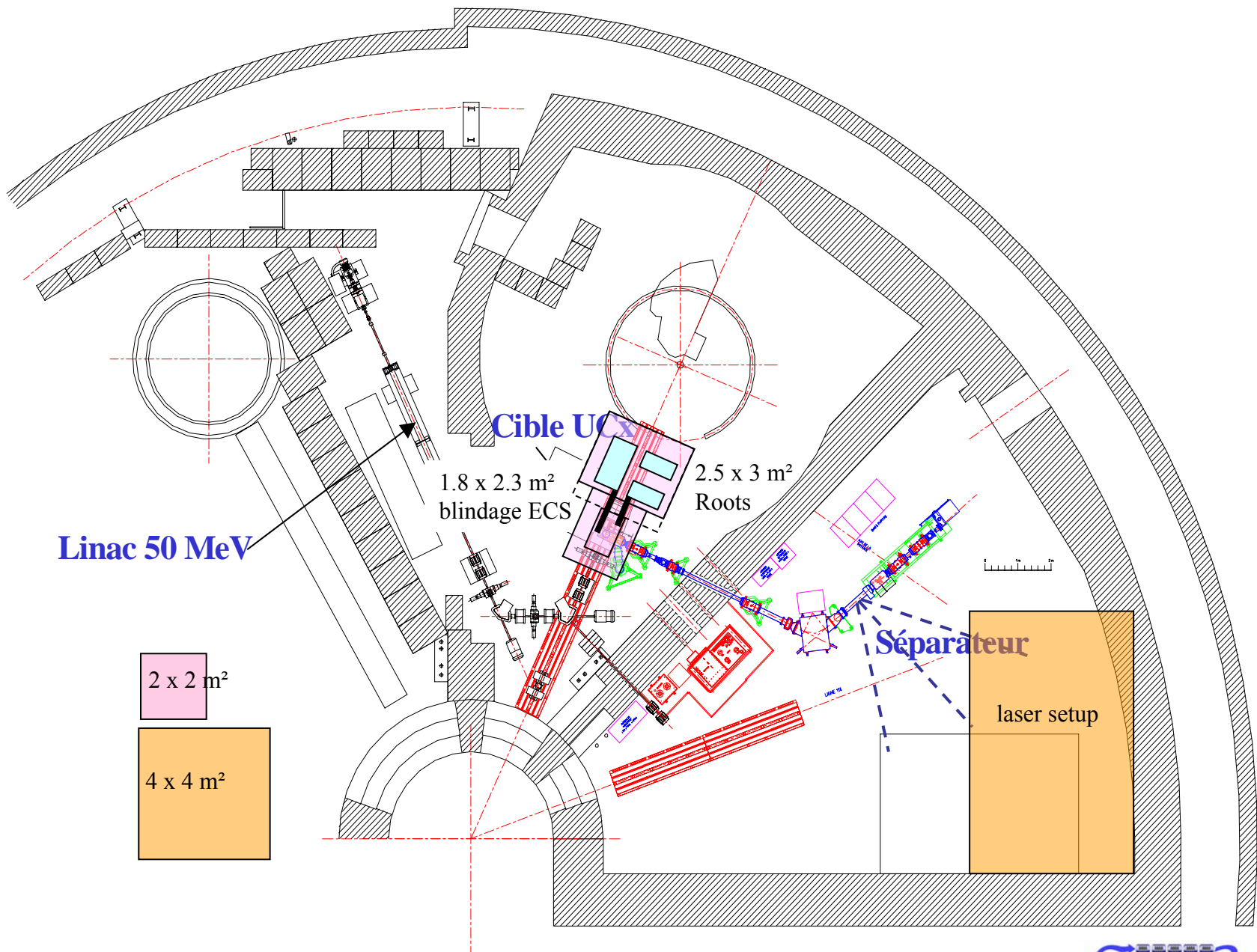

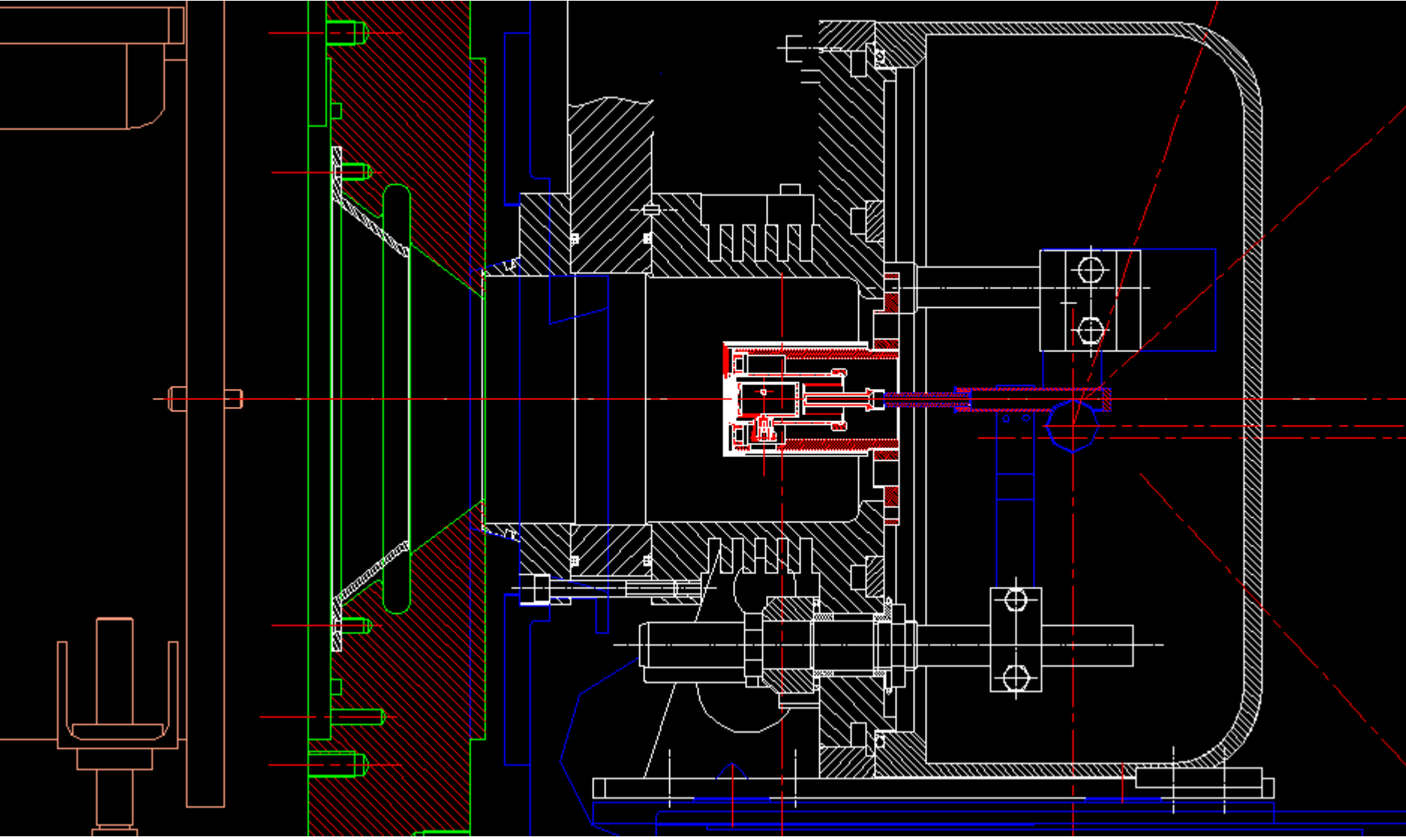

laser oil cooling gas supply

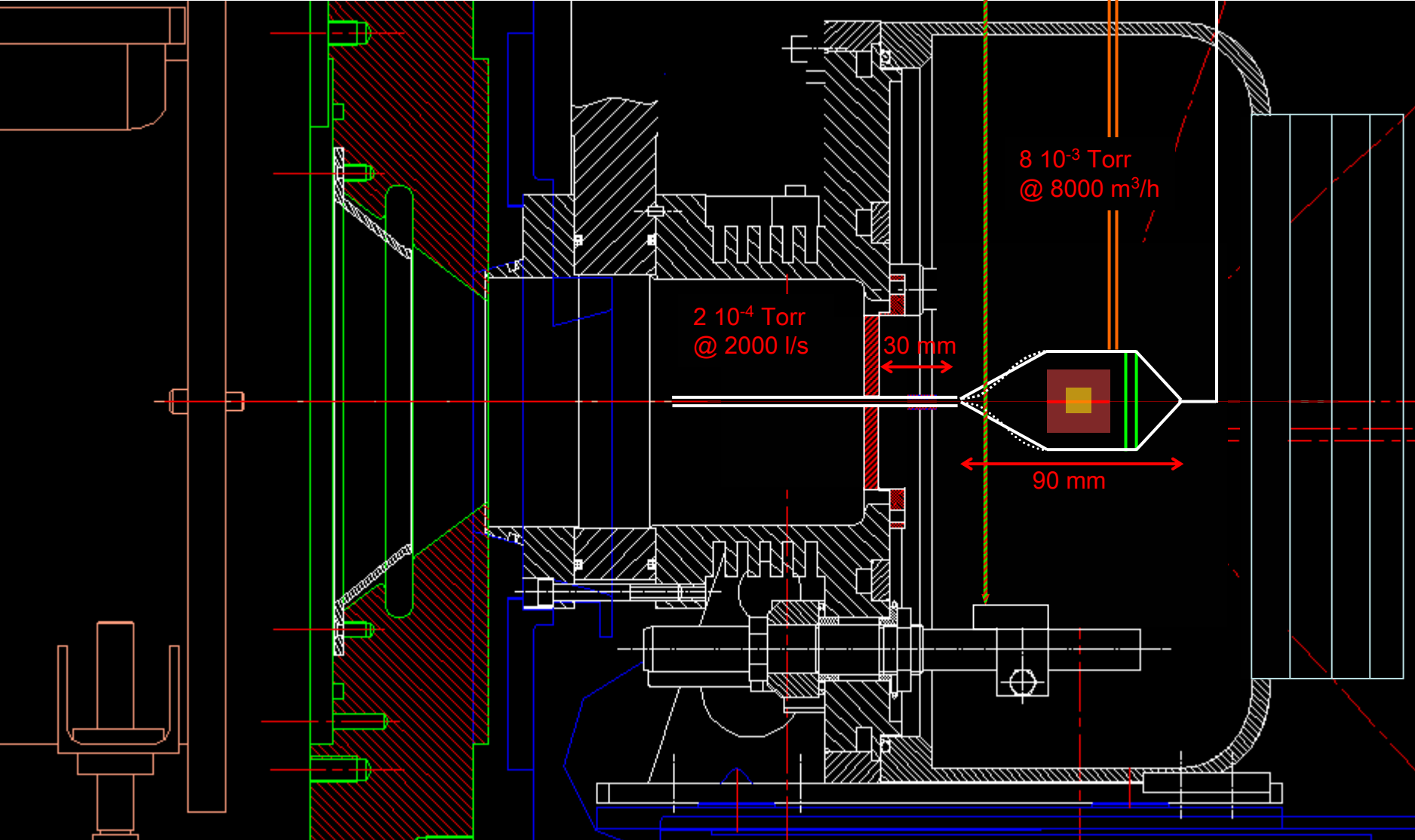

$$\sigma^{238}\text{U}(\gamma, f) = 160 \text{ mb}$$

$$P_{\text{is}}(f) \sim 3.6 \cdot 10^9 / 10 \mu\text{C}$$

$$\varepsilon_{\text{Alto}} \sim 3 \cdot 10^{-3}$$

Expected extracted ions (pure beam)

$$P_{\text{is}}(^{78}\text{Ni}) = 1.9 \cdot 10^3 / \text{s}$$

$$P_{\text{extr}}(^{78}\text{Ni}) = 5.6 / \text{s} \quad N=50 \quad Z=28$$

$$P_{\text{is}}(^{110}\text{Zr}) = 6.6 \cdot 10^3 / \text{s}$$

$$P_{\text{extr}}(^{110}\text{Zr}) = 20 / \text{s} \quad N=70 \quad Z=40$$

$$P_{\text{is}}(^{123}\text{Rh}) = 7.2 \cdot 10^4 / \text{s}$$

$$P_{\text{extr}}(^{123}\text{Rh}) = 216 / \text{s} \quad N=78 \quad Z=45$$

$$P_{\text{is}}(^{128}\text{Pd}) = 1.4 \cdot 10^2 / \text{s}$$

$$P_{\text{extr}}(^{128}\text{Pd}) = 0.4 / \text{s} \quad N=82 \quad Z=46$$

Physics case with ALTO and experimental set-ups needed

Some examples

Study of neutron rich nuclei around $N=50$ (D. Verney, S. Franchoo et al.)

Study of neutron-rich nuclei around N=50

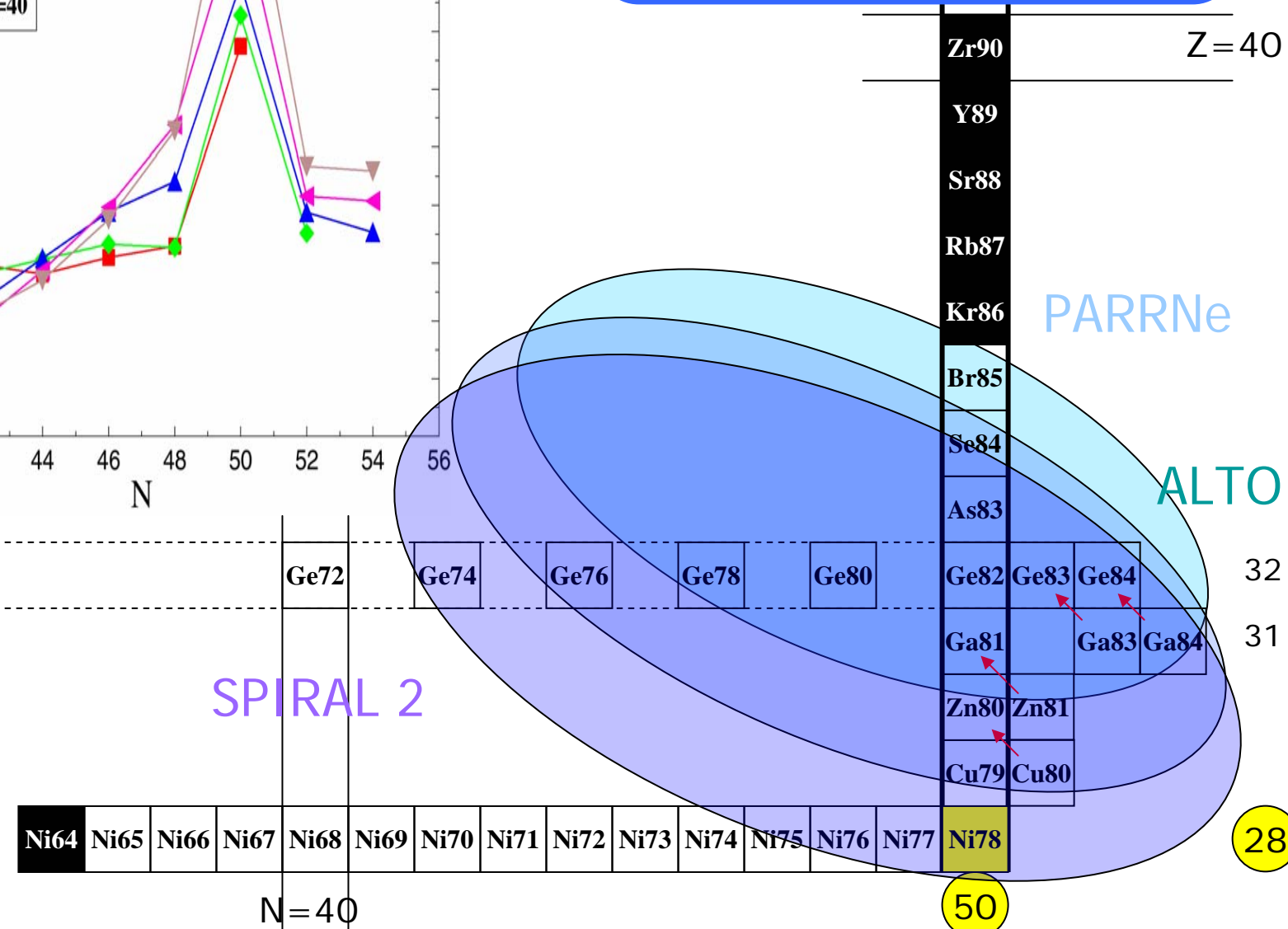
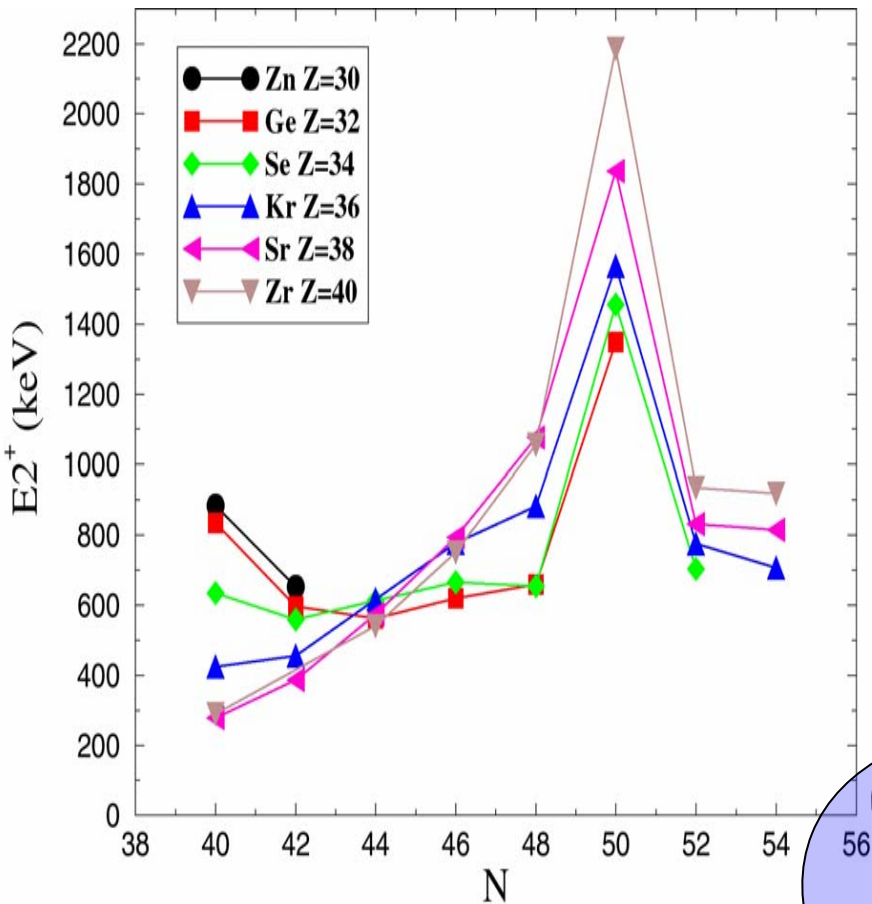

Physics case with ALTO and experimental set-ups needed

Some examples

Study of neutron rich nuclei around $N=50$

Laser spectroscopy at ALTO (F. Le Blanc et al.)

Laser spectroscopy at ALTO

Ion source

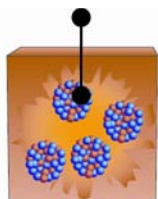

separator

lenses

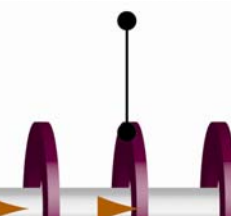

Separated beam

Charge exchange cell

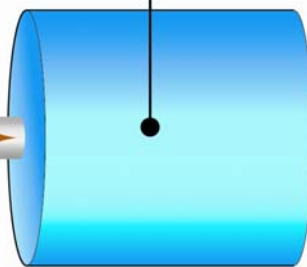

PM



mirror

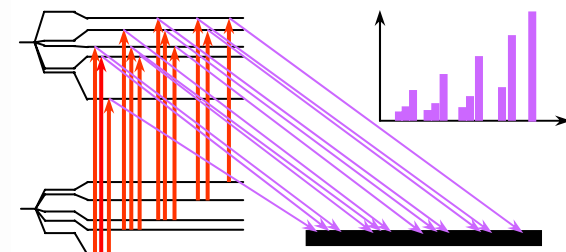

Pulsed laser

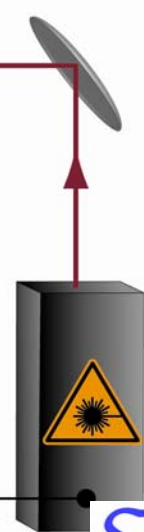

Physics case with ALTO and experimental set-ups needed

Some examples

Study of neutron rich nuclei around $N=50$

Laser spectroscopy at ALTO

β strength functions (B. Rubio, B. Gelletly et al.)

Physics case with ALTO and experimental set-ups needed

Some examples

Study of neutron rich nuclei around $N=50$

Laser spectroscopy at ALTO

β strength functions

βn $\beta 2n$ measurements (E. Sokol et al.)

Detector with ^3He counters

- **Advantages**
- Zero energy threshold
- Zero cross-talk
- High efficiency
- Low gamma sensitivity
- Low internal background
- Easy in use
- Now ready 140 modules

Nuclides	$T_{1/2}, \text{s}$	$Q_{\beta} - B_{2n}, \text{MeV}$	$P_{2n}, \%$	$Y, 1/f$
^{86}As	0.90	1.33	0.02	$4.0 \cdot 10^{-4}$
^{94}Br	0.07	3.78	3.12	$1.3 \cdot 10^{-5}$
^{112}Nb	(0.10)	3.79	1.28	$6.1 \cdot 10^{-10}$
^{134}In	0.1	5.54	99	$2.7 \cdot 10^{-7}$
^{136}Sb	0.8	2.25	10.6 0.28	$3.3 \cdot 10^{-4}$
^{142}J	0.2	2.28	0.76	$5.3 \cdot 10^{-5}$
^{150}Cs	(0.15)	2.97	1.48	$1.3 \cdot 10^{-8}$

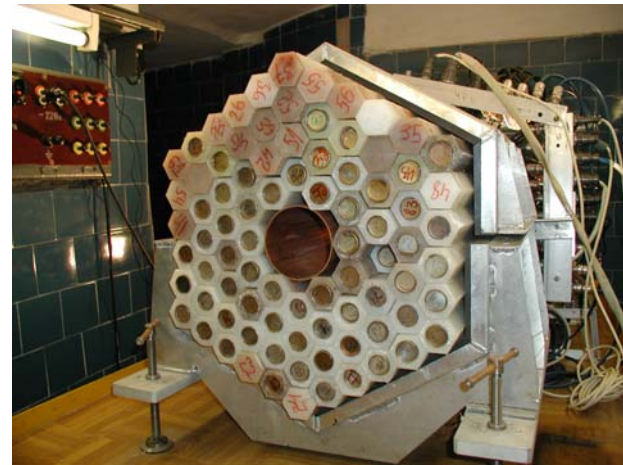

Physics case with ALTO and experimental set-ups needed

Some examples

Study of neutron rich nuclei around $N=50$

Laser spectroscopy at ALTO

β strength functions

βn $\beta 2n$ measurements

g factor measurements (G. Georgiev et al.)

Physics case with ALTO and experimental set-ups needed

Some examples

Study of neutron rich nuclei around $N=50$

Laser spectroscopy at ALTO

β strength functions

βn $\beta 2n$ measurements

g factor measurements (G. Georgiev et al.)

Fast timing measurements (H. Mach et al.)

Programme de physique à ALTO et dispositifs expérimentaux nécessaires

Quelques exemples

Etude des noyaux riches en neutrons autour de $N=50$ (D. Verney, S. Franchoo et al.,)

Spectroscopie laser à ALTO (F. Le Blanc et al.,)

β strength functions (B. Rubio, B. Gelletly et al.)

Mesure de décroissances βn $\beta 2n$ (E. Sokol et al. Dubna)

g factor measurements (G. Georgiev et al.)

Fast timing measurements (H. Mach et al.)

Nuclear astrophysics (F. Hammache, O. Sorlin, S. Grévy, K.L. Kratz)

—————→ Refractory elements : R&D thick target + ALIGRE

Physics case with ALTO and experimental set-ups needed

Some examples

Study of neutron rich nuclei around $N=50$

Laser spectroscopy at ALTO

β strength functions

βn $\beta 2n$ measurements

Need for a dedicated high efficiency Ge set-up

Need for pure beams

At the tandem:

Dedicated set-up for campaigns with sufficient beam time!

Gamma spectroscopy:

- **OSCAR**: Orsay Segmented Clover Array

γ -Ring : 4 segmented clovers @ 6cm

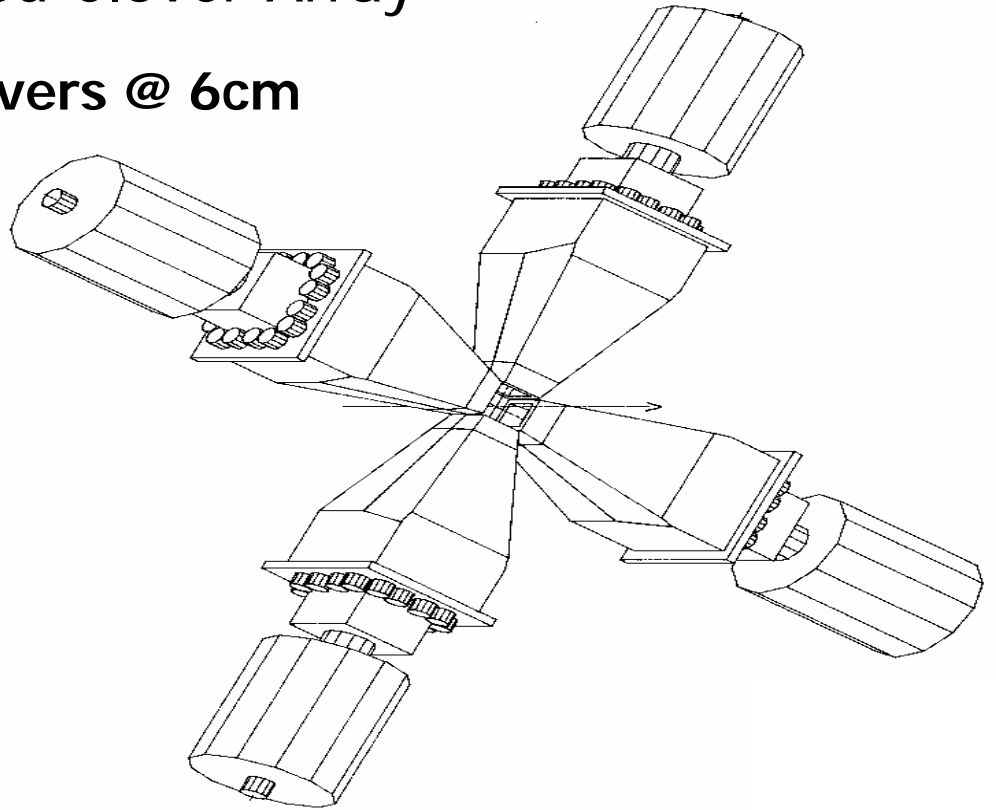

Evolution of the experimental area with ALTO

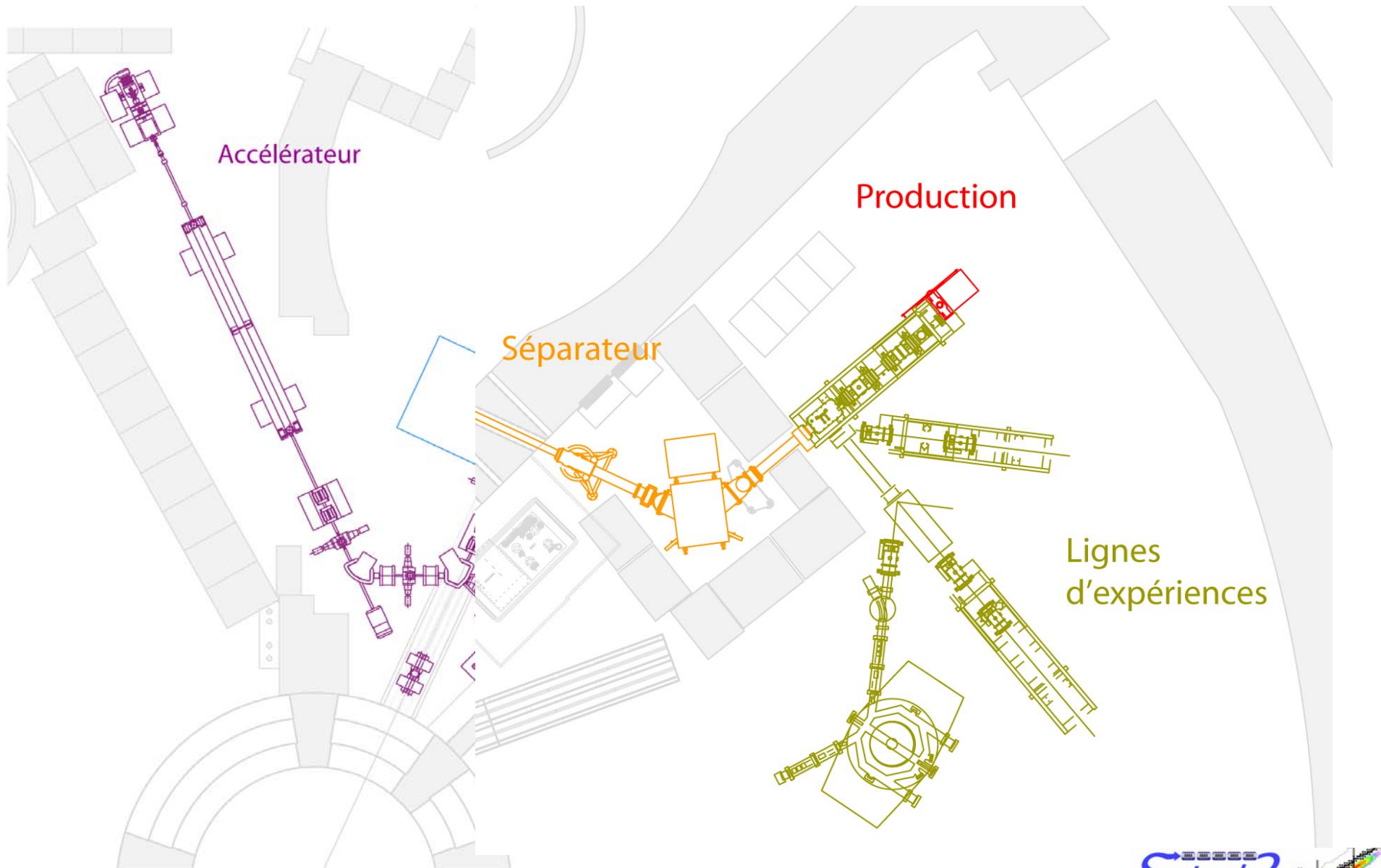

The tape transport system

Characteristics needed :

- displacement of 1 m in 0.1 s
- precision of ± 1 mm
- large autonomy : some kms of tape
- maximal number of displacements 2 per second
- 10^{-6} T at the collection point
- commanded by PC :
 - quick rewinding
 - elementary phases (collection, waiting, measure, displacement) with associated TTL signal \rightarrow cycle
 - auto-reverse

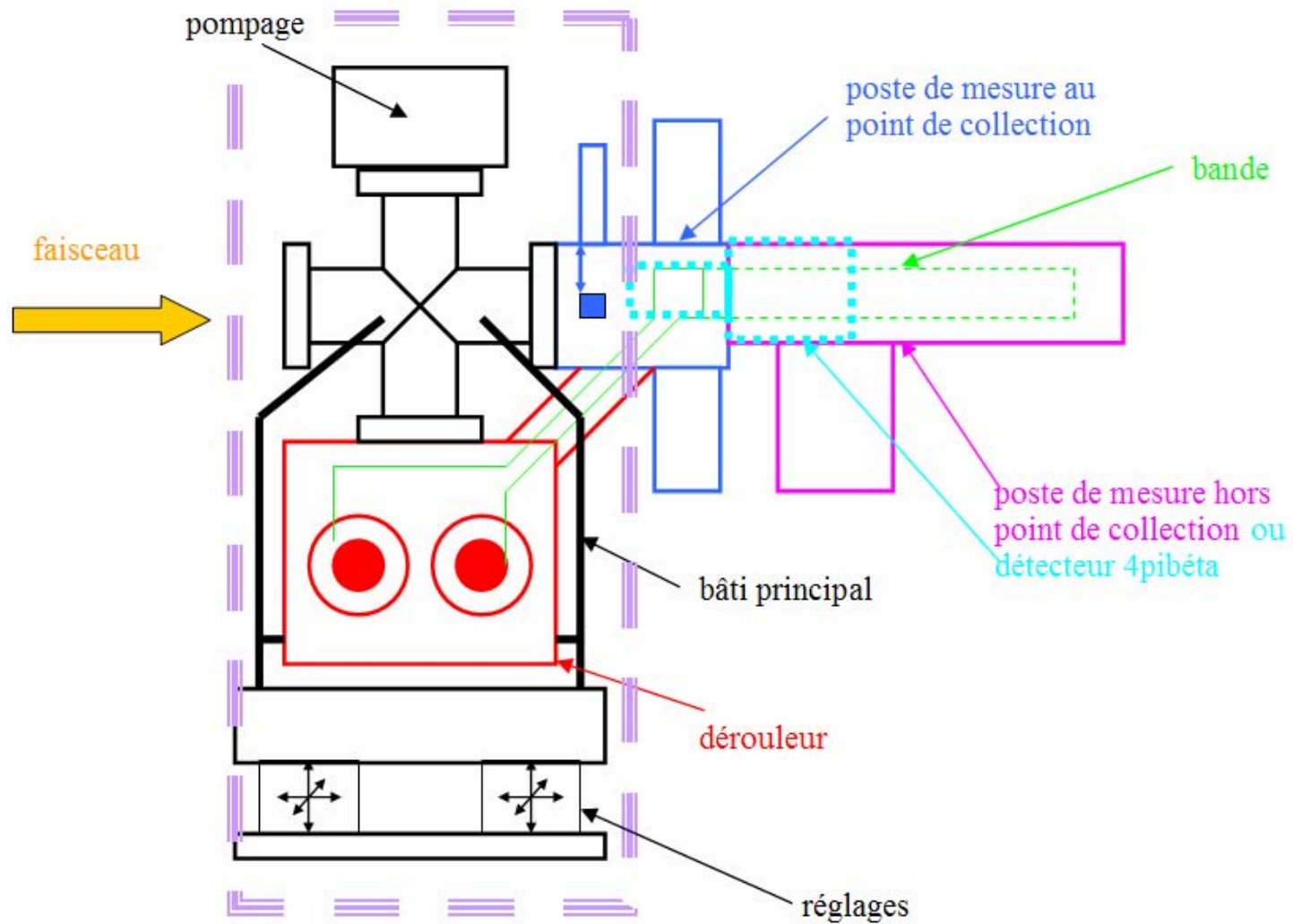

**Tape transport system
principle
(B. Lesellier, Y. Ollivier)**

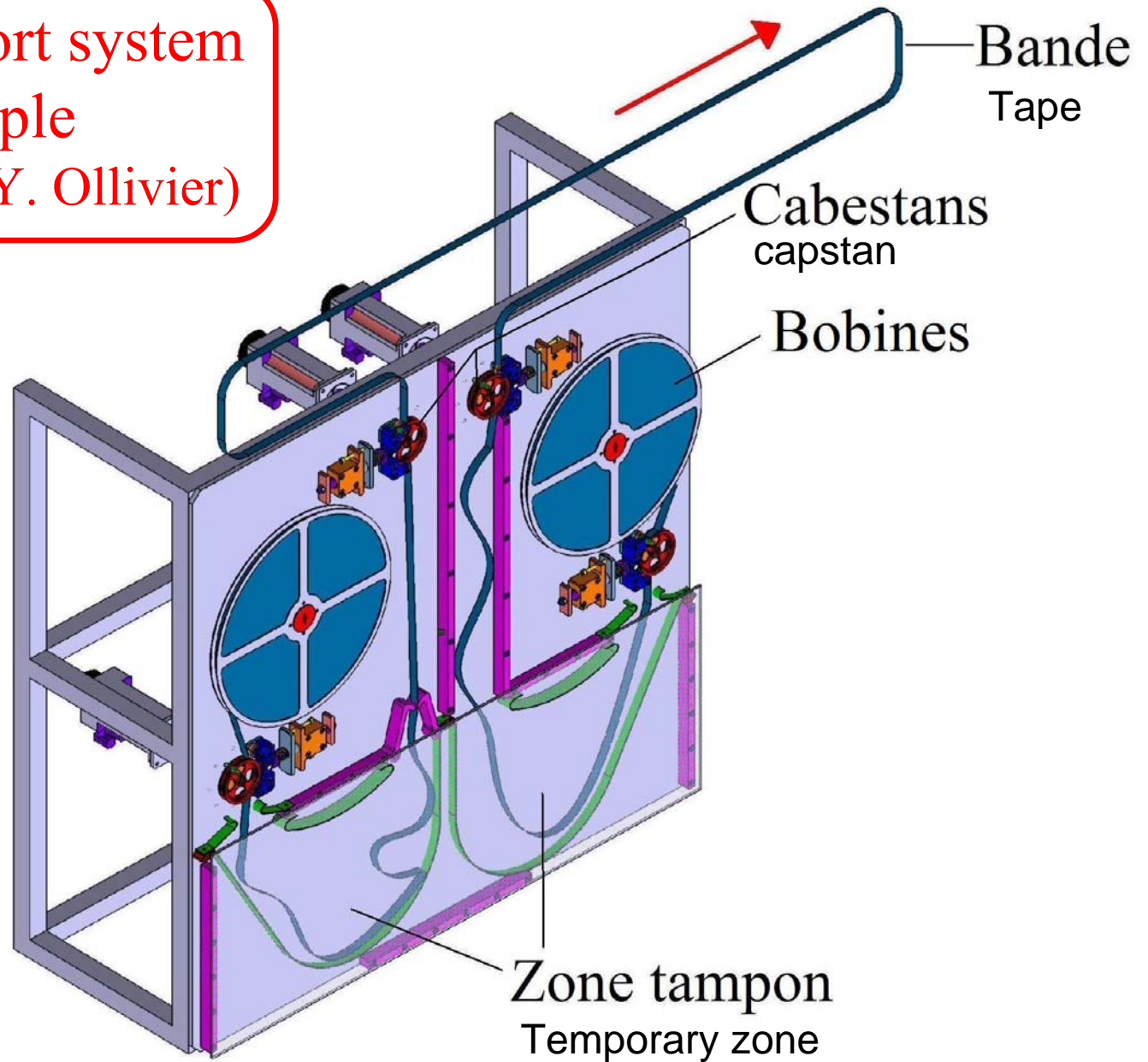

Prototype

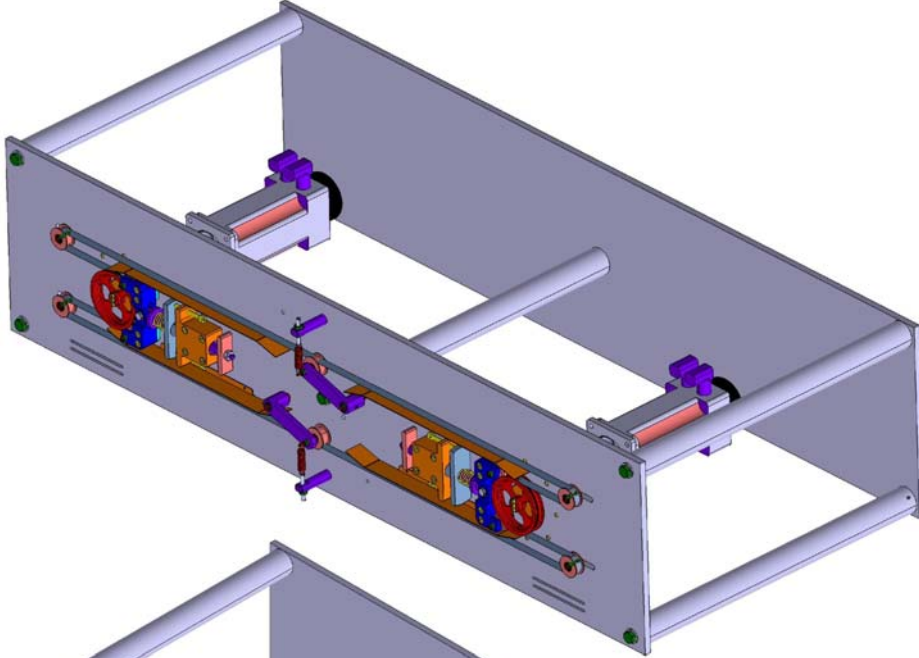

⇒ Test speed and reproducibility
1 m in 0.1 s, ± 1 mm

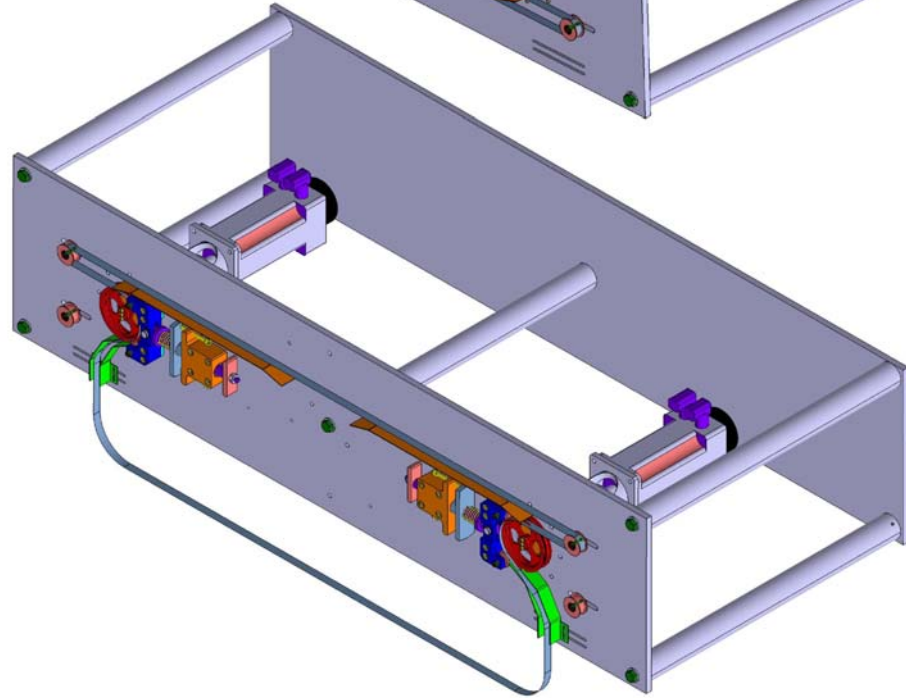

⇒ Test the temporary zone, define
the guidance between the temporary
zone and the capstan

Etat d'avancement

- Drawing of the prototype finished end march
- construction of the prototype : till June
- Prototype delivered mid July
- Tests in September

And the 22th of december 2005 ...
at 3pm

- The end of the
ALTO *project*
- Begin of the
ALTO *facility*



July 2006 confirmation of the estimation

