

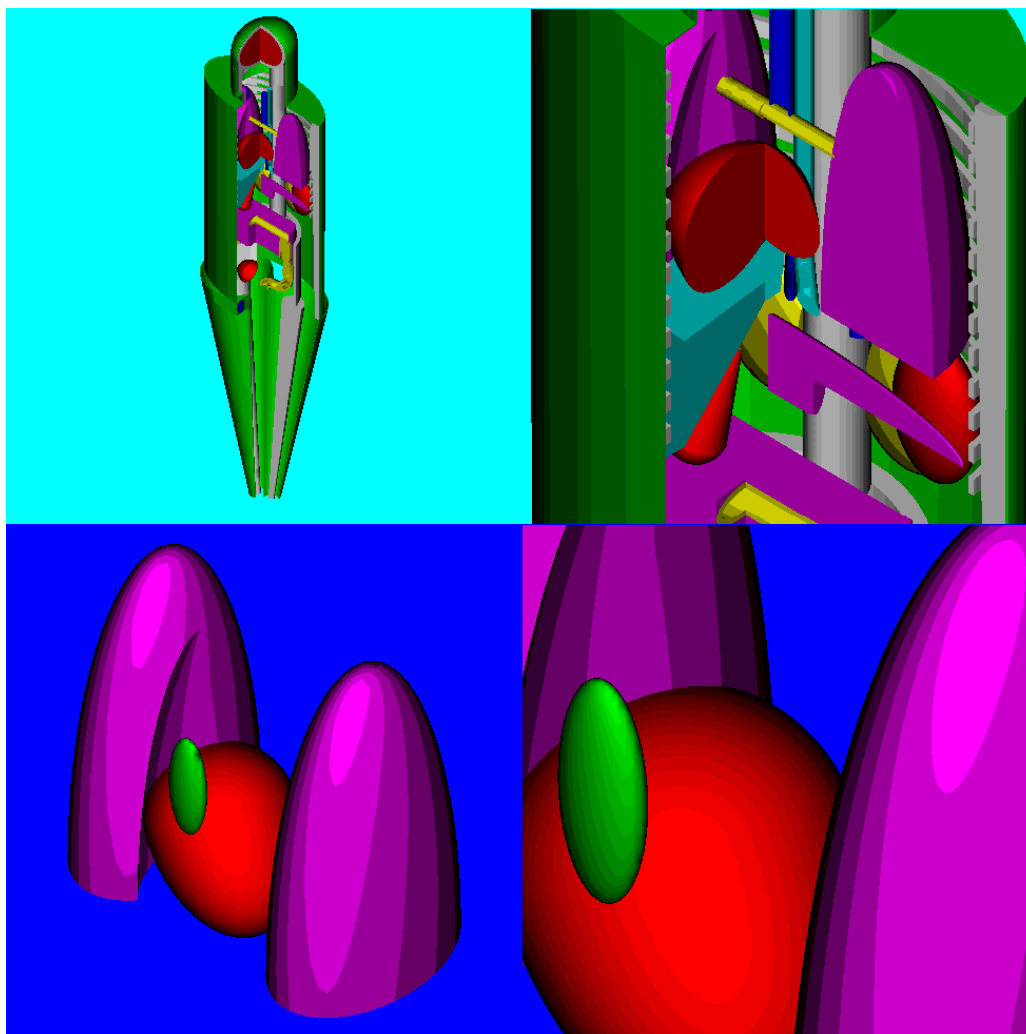

European Commission

QUADOS
“Quality Assurance of
Computational Tools for Dosimetry”

**INTERCOMPARISON ON THE USAGE OF
COMPUTATIONAL CODES
IN RADIATION DOSIMETRY**



Istituto di Radioprotezione

Concerted Action: §

“ Quality Assurance of Computational Tools for Dosimetry ”

Chairman: Bernd Siebert

§ Supported by the European Commission, DG XII under Contract FIGD-CT-2000-20062

EC Concerted Action:

“Quality Assurance of Computational Tools for Dosimetry”

Stefano Agosteo¹, Jean-Louis Chartier², Bernd Großwendt³, Gianfranco Gualdrini⁴, Ivan Kodeli⁵
Peter Leuthold⁶, Stéfanie Ménard⁷, Robert Price⁸, Bernd Siebert⁹, Hamid Tagziria¹⁰,
Rick Tanner¹¹, Michel Terrisol¹², Maria Zankl¹³

- 1) Dipartimento Ingegneria Nucleare, Politecnico di Milano, v. Ponzio 34/3 I-20133 Milano, Italy
- 2) Consultant - IRSN DPHD SDOS LRDE, BP6, F-92265, Fontenay-aux-Roses, Cedex, France
- 3) PTB, Postfach 3345, D-38023 Braunschweig, Germany
- 4) ENEA ION-IRP, Via dei Colli 16, I-40136 Bologna, Italy
- 5) Institut Jozef Stefan, Jamova 39, 1000 Ljubljana, Slovenia
- 6) GSF, Ingolstadter Landstrasse 1, D85764 Neuherberg, Germany
- 7) IRSN DPHD SDOS LRDE, BP6, F-92265, Fontenay-aux-Roses, Cedex, France
- 8) Clatterbridge Centre for Oncology, Clatterbridge Road, Bebington CH63 4JY, UK.
- 9) PTB, Postfach 3345, D38023 Braunschweig, Germany
- 10) National Physical Laboratory, Queens Road, Teddington, TW11 0LW, UK
- 11) NRPB, Chilton, Didcot, Oxon OX11 0RG, UK
- 12) CPAT, University Paul Sabatier, 118 route de Narbonne, F-31062 Toulouse Cedex 4, France
- 13) GSF, Ingolstadter Landstrasse 1, D85764 Neuherberg, Germany

Intercomparison on the Usage of Computational Codes in Radiation Dosimetry

“QUADOS”[‡], a Concerted Action of the European Commission, is running an intercomparison aimed at evaluating the use of computational codes for dosimetry in radiation protection and medical physics. This intercomparison is open to all users of Monte Carlo, analytic and semi-analytic codes or deterministic methods, from both inside and outside the European Union, regardless of their field of work. It is intended to:

- Provide a snapshot of the methods and codes currently in use
- Furnish information on the methods used to assess the reliability of computational results
- Disseminate “good practice” throughout the radiation dosimetry community
- Provide the users of computational codes with an opportunity to quality assure their own procedures
- Inform the community about the benefits to be obtained from sensitivity and uncertainty analysis
- Inform the community about more sophisticated approaches that may be available to them

Eight problems have been selected for their relevance to the radiation dosimetry community. They are relatively undemanding in terms of set-up time and CPU required. Nevertheless, they provide reasonably relevant examples for those who use computational codes in their work. It is hoped that both “casual” and “expert” users will participate in this study.

Each problem includes the name and e-mail address of its originator, so that clarification on the problem specification may be sought. Some problems contain more than one stage. Although calculation of the full problem is encouraged, participants are also welcome to submit calculations that proceed as far as their time allows.

*Results should be returned in electronic format. ASCII files should be provided to facilitate a complete analysis of the returns. A brief text discussing the procedures employed for solving the problems should also be supplied. **The deadline for the submission of results is 15 October 2002.***

These eight problems are, in summary:

- P1. Brachytherapy: ^{192}Ir γ -ray source. Calculation of angular anisotropy and dose distribution in water.
- P2. Endovascular: ^{32}P β -source. Calculation of the dose in the vessel wall along the longitudinal axis of the source and the radial dose profile.
- P3. Proton therapy on the eye: 50 MeV proton beam incident on an eye water phantom. Calculation of the depth dose distribution and isodose curves in the water phantom.
- P4. TLD-albedo dosimeter response calculation: neutron and/or photon sources. Calculation of the neutron and/or photon response of a 4-element TL dosimeter mounted on a standard ISO slab phantom.

[‡] FIGD-CT-2000-20062: “Quality Assurance of Computational Tools for Dosimetry”

- P5. Phantom backscatter: X ray ISO reference beams. Calculation of the air kerma backscatter factor profiles and the energy distribution of the backscatter photon fluence along the face of a standard ISO slab phantom.
- P6. Environmental scatter: bare ^{252}Cf neutron source located at the centre of a concrete walled calibration room. The use of a shadow cone is studied.
- P7. Germanium detector: photon sources with energies in the range from 15 keV to 1 MeV. The pulse height distribution in a germanium detector is studied.
- P8. Consistency check device: ^{241}Am -Be neutron source. Sensitivity to the relative position of the radioactive source and a simplified ^3He neutron area survey meter.

All participants will receive a final report that will contain a detailed analysis of the results of each problem. All results will be presented anonymously.

The final report will also include sections on uncertainty analysis and advanced tools that are available for computational dosimetry. These are considered to be of great relevance to all who use computational codes either as the main part of their job, or as a tool to aid them in their work.

A three-day workshop is planned: sample solutions will be presented by the authors of the problems, including an analysis of the returns (the anonymity of the participants will be preserved). However, participants who wish to do so, are encouraged to report their experiences in solving the problems.

The electronic version of the present document is available on <http://www.nea.fr/download/quados/quados.html>.

The results should be returned by E-mail to each author (at the address indicated at the end of each problem specification) **and** to:

Dr. Ivo Kodeli
OECD/NEA DATA BANK
ivo.kodeli@oecd.org

P1. ^{192}Ir Brachytherapy source problem

Introduction

The problem is to study the near-field dosimetry of an HDR (High Dose Rate) ^{192}Ir source. You should attempt any or all parts of the problem. For the purposes of this example, near-field is defined as the distance below which the source can no longer be considered as a point source (approximately < 5 cm). In the near-field, the dose distribution is not isotropic but is markedly dependent on angle. In dosimetry calculations this anisotropy can be handled by using a table of published anisotropy correction factors – defined to be the ratio of the absorbed dose at an angle to the absorbed dose at 90° (both values are at a given radial distance from the source).

Source Geometry

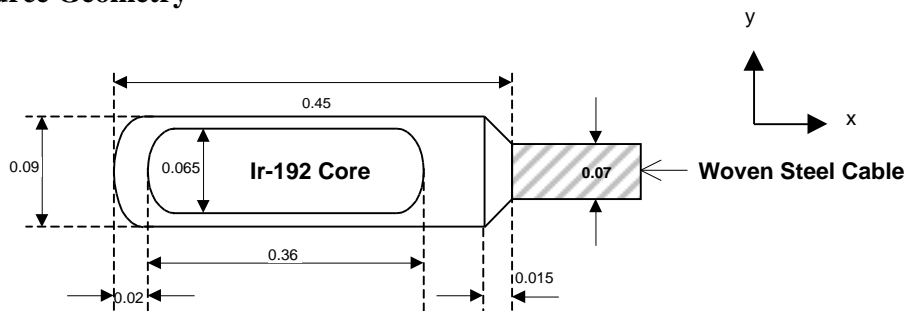

Figure 1: The HDR ^{192}Ir source. All dimensions are given in cm. The spherical end of the encapsulation is a sphere of diameter 0.122 cm arranged so that the distance from the encapsulation tip to the source tip is 0.02 cm. The curved ends of the core are formed from spheres of diameter 0.065 cm.

The HDR source (Figure 1) consists of a cylindrical pellet of pure ^{192}Ir – the core (density 22.42 g cm^{-3}) with rounded ends (diameter 0.065 cm). The maximum diameter of the core is 0.065 cm. The core encapsulation is stainless steel (AISI Type 316L, 2% Mn, 1% Si, 17% Cr, 12% Ni, 68% Fe by weight, density 8.02 g cm^{-3}) of maximum diameter 0.09 cm and maximum length 0.45 cm. One end of the encapsulation is formed from a sphere (diameter 0.122 cm) positioned so that the distance from the tip of the encapsulation to the tip of the core is 0.02 cm. The other end of the capsule is welded to a woven steel cable of diameter 0.07 cm and density 4.81 g cm^{-3} .

Energy Spectrum

The energy spectrum for ^{192}Ir source can be obtained from the web site at the following address <http://members.aol.com/rprice1495/data/Ir192>

The problems

Question 1:

Compile a table of anisotropy factors (in homogeneous liquid water). Factors are to be calculated for:

- radii of 1 to 5 cm in 1 cm increments (measured along the y-axis from the geometric centre of the source)
- angles of 0° to 180° in 10° increments (relative to the negative x-direction, with 0° pointing from the centre of the core towards the steel cable).

The centre of co-ordinates should be positioned at the geometric centre of the core (equal to 0.2 cm from the encapsulation tip).

Question 2:

Calculate the dose distribution (in homogeneous liquid water) for a hypothetical treatment scenario in which the source is stepped and dwelled in a given configuration inside an AISI Type 316L steel cylindrical tubular catheter with an internal diameter of 2.1 mm and an external diameter of 3.16 mm (composition and density as specified for the source above). The relative dose distribution (normalised to the dose at P) is to be calculated along a line running parallel to the catheter and situated 1cm from its major axis - see figure 2. The dose distribution required is the absorbed dose (in water) along the line after the source has been stepped and dwelled. The source, which is defined as above, is stepped according to table 1. The dwell times shown are relative times (i.e. the source is occupying position 5 for the same duration as it occupies position 6; it occupies position 4 for a duration equal to 80% of that at position 6, etc) and it is assumed that the source is moved instantaneously between the dwell points. The tip of the capsule defines the location of the dwell points.

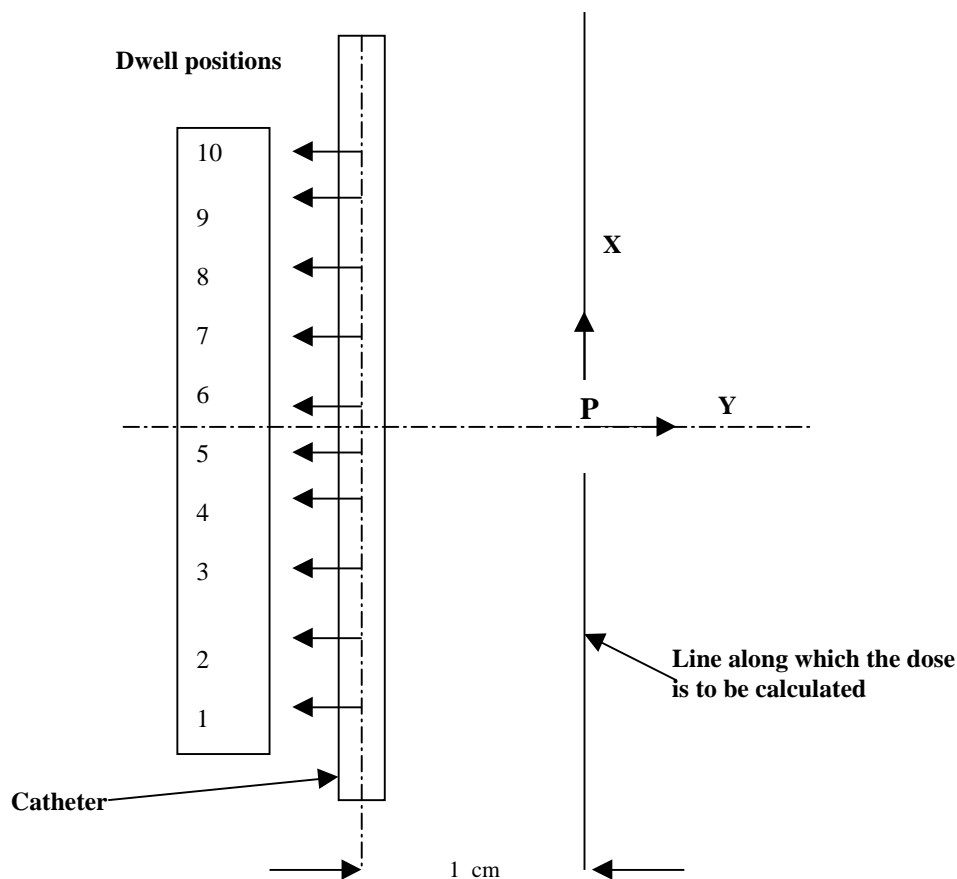

Figure 2: The ^{192}Ir source is stepped along the catheter shown. The source sequentially occupies positions 1 to 10 for a given dwell time and is assumed to move instantaneously between dwell points. The resulting near-field dose distribution (normalised to the dose at P – the mid point of travel) is to be calculated along a line that is parallel to the catheter and 1 cm distant from its major axis. Point doses should be calculated along the line at point P , at intervals of ± 2 mm from P and at any intermediate points the participant wishes.

Table 1: Dwell positions along the x-axis (relative to the point P, with the x-axis pointing up) and relative dwell-times.

Dwell point	1	2	3	4	5	6	7	8	9	10
X co-ordinate (cm)	-1.44	-1.08	-0.72	-0.36	-0.18	+0.18	+0.36	+0.72	+1.08	+1.44
Relative Dwell time	0.3	0.3	0.4	0.8	1	1	0.8	0.4	0.3	0.3

Correspondence

Results should be returned before 15 October 2002 to:

Dr Robert Alan Price PhD MIPEM SRCS
Physics Department
Clatterbridge Centre for Oncology
Clatterbridge Road, Bebington
Wirral
Merseyside, CH63 4JY, UK
E-mail: RobertP@ccotrust.co.uk

P2. Endovascular radiotherapy problem.

Intravascular brachytherapy using sources such as the beta emitting nuclide ^{32}P has been shown to prevent neointimal proliferation after procedures such as coronary balloon angioplasty. An increasing number of hospitals are now offering intravascular brachytherapy using commercial systems. Dosimetry is clearly very important for this procedure but measurements are difficult to perform on these devices due to the very steep dose gradients near the source.

In this problem, the participant is asked to calculate radial and longitudinal dose distributions and to investigate the effect on the dose to the vessel wall when a plaque is included or when the source is asymmetrically placed in the lumen.

Figures 1 and 2 show the geometry of the system. The endovascular needle (which for simplicity has no balloon centring mechanism) is placed within a water phantom. The dimensions of each component are shown in these diagrams, whilst their elemental composition and mass density are given in the accompanying table. The questions to be answered are provided in the boxed text sections.

Endovascular radiation therapy: data and problem statement

Source data:

^{32}P is held in a polyethylene matrix. Density = 1.12 g cm^{-3} .

Source Strength = 7 GBq

Elemental composition of materials % by weight:

Element	Water	Soft tissue	Plaque	NiTi -alloy	^{32}P Source	Air
H	11.2	10.1	6.141	-	9.677	-
C	-	11.1	40.302	-	38.710	-
N	-	2.6	1.919	-	-	79.0
O	88.8	76.2	29.884	-	51.613	21.0
P	-	-	10.254	-	-	-
Ca	-	-	11.5	-	-	-
Cr	-	-	-	0.25	-	-
Ni	-	-	-	55.8	-	-
Ti	-	-	-	43.95	-	-
density (g cm^{-3})	1.00	1.04	1.45	6.45	1.12	0.00120484

Source spectrum: Full spectrum available from <http://members.aol.com/rprice1495/data/P32> or from ICRU 56

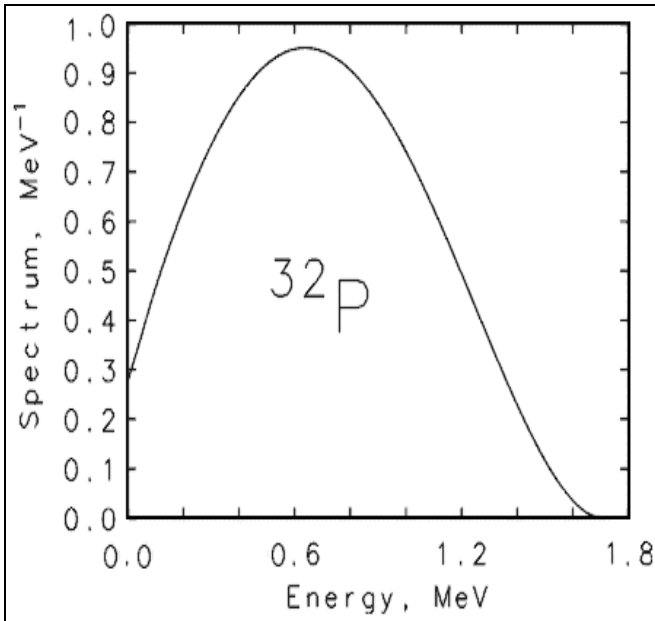

- ii) Calculate the dose rate along the source longitudinal axis, at a depth of 1 mm into the artery wall from the inside surface.
- iii) Calculate the radial dose rate profile out to at least 10 mm from the centre along a perpendicular bisector of the source axis.
- iv) Calculate the dose rate to the artery wall (1 mm in from the inside surface and mid way along the source longitudinal axis).
- v) Investigate the changes in ii) and iii) when an annular plaque of thickness 0.5 mm, length 3 cm is present on the inside wall of the artery, positioned centrally about perpendicular bisector of the source long axis

Optional:

- i) Investigate the effect on the above of changes in plaque density.
- ii) Investigate the effect on the above of off-centre positioning of the needle - i.e. position the needle so that it touches the plaque (or artery wall when no plaque is present).

Modelling the radiation dose distributions: endovascular radiation therapy

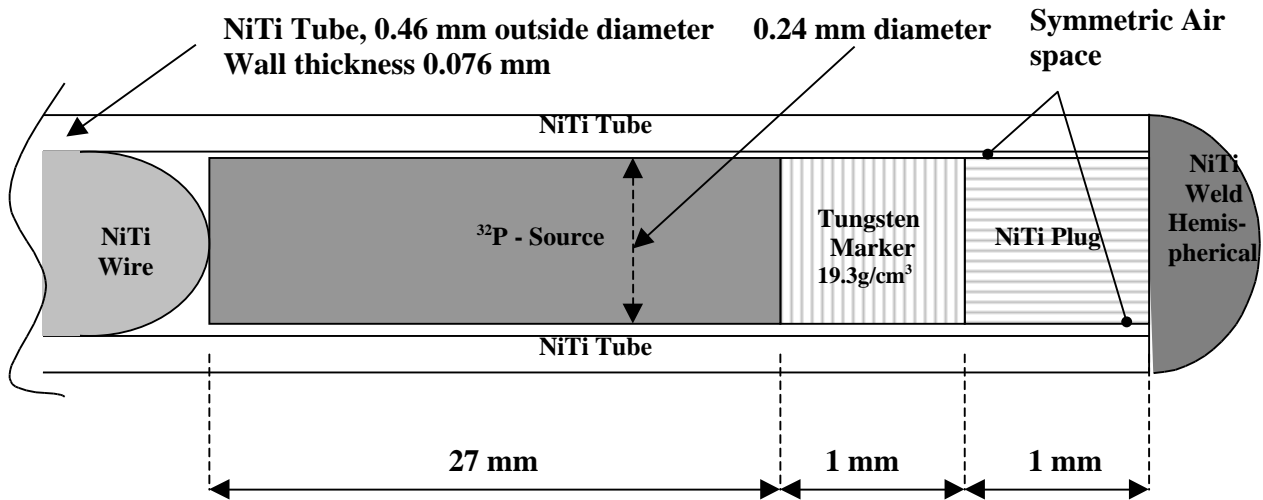

Fig.1 : The endovascular needle (Not to scale)

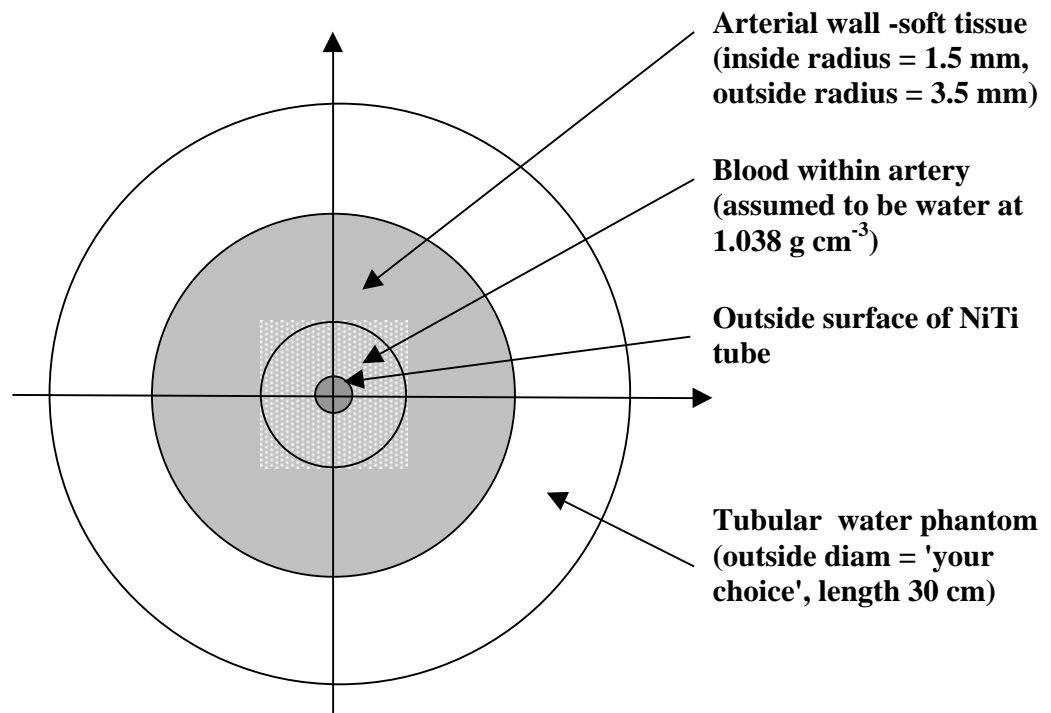

Fig.2 : Catheter, vessel and phantom (Not to scale).

Notes:

1. The symmetric space between inner surface of NiTi wall and source, etc, is filled with air, assumed to be at STP.
2. The NiTi weld and end of the NiTi wire are hemispherical.
3. In reality, the overall length of the needle is 2430 mm from the end of the weld to the distal end of the guide wire but the overall length of the NiTi wire to be modelled is at the discretion of the modeller.
4. The water phantom is 30 cm long
5. The needle is positioned coaxially in the water phantom with the centre of the ^{32}P source coincident with the centre of the phantom.

Correspondence

Results should be returned before 15 October 2002 to:

Dr Robert Alan Price PhD
MIPeM SRCS
Physics Department
Clatterbridge Centre for Oncology
Clatterbridge Road, Bebington
Wirral
Merseyside, CH63 4JY, UK
E-mail: RobertP@ccotrust.co.uk

P3. Dose distribution of a proton beam in a water phantom

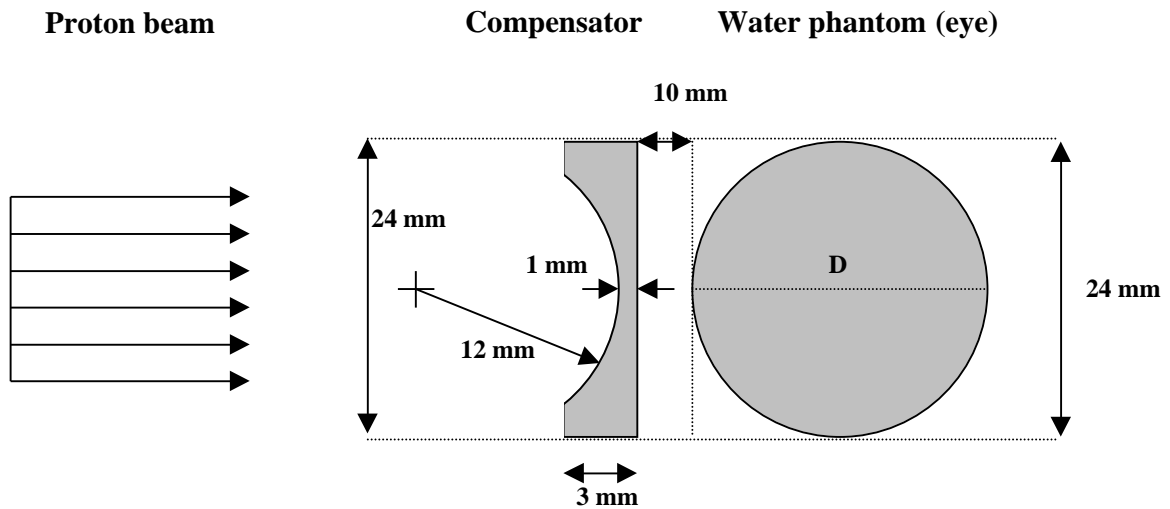

Fig.1 : problem scheme (not to scale)

A parallel beam of protons from a disk source (diameter 15 mm) impinges on a PMMA compensator (cylindrical symmetry) and on a spherical water phantom approximating an eye (figure 1). All elements are in vacuum. If discrete regions are used for dose calculations (depth-dose and isodose curves), use voxels with dimensions $0.5 \times 0.5 \times 0.5 \text{ mm}^3$.

Part 1:

Consider a 50 MeV monoenergetic beam. Calculate:

- 1) the depth-dose distribution in the spherical phantom along the diameter D parallel to the proton beam direction;
- 2) optional – the 90%, 80% and 20% isodose curves on the equatorial plane of the water phantom parallel to the beam direction.

Part 2:

Simulate the effect of a beam modulator by sampling the source according to the discrete distribution in energy listed in Tab. 1 (or alternatively calculate the weights for spreading out the Bragg peak referring to energies in the range 40-50 MeV), calculate:

- 1) the depth-dose distribution in the spherical phantom on the diameter parallel to the proton beam direction;
- 2) optional – the 90%, 80% and 20% isodose curves on the equatorial plane of the water phantom parallel to the beam direction.

The results should be normalized to one primary proton.

Problem Specifications:

WATER PHANTOM : a sphere 24 mm in diameter

PMMA density = 1.19 g cm^{-3}

Water density = 1.0 g cm^{-3}

Table 1 - PMMA composition

Element	Composition (weight fraction)
H	0.080538
C	0.599848
O	0.319614

The distance between the compensator plane and the phantom is 10 mm.

Source specification:

A parallel beam from a disk source 15 mm in diameter.

Energy:

Part 1: monoenergetic 50 MeV.

Part 2: discrete energy distribution with the following energies and weights:

Table 2 – Discrete energies and weights for simulating the modulator.

Energy (MeV)	Weight (not normalized)
40	0.12505
41	0.10456
42	0.15547
43	0.14911
44	0.17401
45	0.18622
46	0.21647
47	0.21400
47.5	0.12737
48	0.13946
48.5	0.19498
49	0.25538
49.5	0.13922
50	1.0000

Correspondence

Results should be returned before 15 October 2002 to:

Stefano Agosteo

Dipartimento di Ingegneria Nucleare

Politecnico di Milano

Via Ponzio 34/3

20133 Milano, Italy

stefano.agosteo@polimi.it

P4. Neutron and/or photon response of a TLD-albedo personal dosimeter on an ISO slab phantom

Problem

A four-element TLD-albedo personal dosimeter is located on the centre of the front face of an ISO 30 cm x 30 cm x 15 cm water filled phantom. The four elements differ:

- Element 1 is mainly ${}^6\text{LiF}$, so it detects thermal neutrons, photons and electrons with high efficiency. It has no shielding or build-up in front, but has boron-loaded plastic behind.
- Element 2 is mainly ${}^7\text{LiF}$, so it detects photons and electrons with high efficiency, and thermal neutrons with low efficiency. It has no shielding or build-up in front, but has boron loaded plastic behind.
- Element 3 is mainly ${}^6\text{LiF}$, so it detects thermal neutrons, photons and electrons with high efficiency. It has a 1 mm thick aluminium disc plus 4 mm of boron loaded plastic in front. Behind is a hole in the holder.
- Element 4 is mainly ${}^7\text{LiF}$, so it detects photons and electrons with high efficiency, and thermal neutrons with low efficiency. It has a 1 mm thick aluminium disc plus 4 mm of boron loaded plastic in front. Behind is a hole in the holder.

A full attempt to model this problem involves the use of neutron and photon sources. You may enter results for only one type of source particle, but you are encouraged to model both. A preferred set of source particle energies is given.

The 4-element design of personal dosimeter that is to be modelled could, in principle, give neutron and photon doses separately in a mixed field. That stage of the calculation would require you to apply an LET dependent correction to the energy deposited to obtain the light output. Instead, you are asked to:

- Model the photon response using the absorbed dose to the thermoluminescent material. You should assume that the light output is proportional to dose.
- Model the neutron response by counting ${}^6\text{Li}(n, t){}^4\text{He}$ capture reactions. You should assume that the neutron response is proportional to the number of capture reactions of this type.
- Calculate the fraction of the neutron and photon response that is due to backscatter.

Geometry

Source

The source to be used for all energies is a monoenergetic 30 cm x 30 cm plane parallel beam, incident normal to the front face of the phantom. The problem is to be performed in a vacuum. Source energies for both neutrons and photons are given in the section entitled "Tasks". You should ideally use all of those energies but may submit results for a subset of them.

ISO phantom

The phantom is a standard ISO water filled slab phantom:

- External dimensions 30 cm x 30 cm x 15 cm

- Front wall 30 cm x 30 cm x 0.25 cm
- Side and back walls 1 cm thick
- Phantom filled with light water

Albedo Dosemeter

The albedo dosimeter is located on the front face of the phantom. It is positioned such that the geometric centre of the back face of the dosimeter holder is at the middle of the front face. The dosimeter is mounted on the phantom such that its long axis is vertical. This is a simplified design, loosely based on real designs of albedo dosimeters. Real TLD-material would contain dopants to provide the electron traps, but those materials are present in trace quantities and are not to be modelled. A real dosimeter would also involve the use of encapsulation to prevent UV light from affecting the thermoluminescent detectors.

- Elements 1-4 are described in more detail in Table 1
- The holder is made from natural boron carbide loaded polyethylene (see Table 2)
- External dimensions 35.0 mm x 55.0 mm x 7.9 mm
- The holder thickness is 5 mm on the front and sides, 2 mm thick on the back
- A 1.0 cm diameter cylindrical hole in the holder material is centred over each TLD location. The top two holes are in the front face of the holder, the bottom two in the back face.
- Four TLD-elements of dimensions 3.2 mm x 3.2 mm x 0.9 mm are located in a 0.9 mm thick aluminium plate
- The plate that holds the TLD-chips is to be considered as pure aluminium and has external dimensions of 25.0 x 45.0 x 0.9 mm
- A 1 mm thick aluminium disc is located with the holder material immediately in front of TLD elements 3 and 4. This is present to ensure that those elements are approximately optimized to measure $H_p(10)$.

Table 1 Composition, shielding and location of the TLD-chips

Element	1	2	3	4
x-offset	-0.75 cm	+0.75 cm	-0.75 cm	+0.75 cm
y-offset	+1.75 cm	+1.75 cm	-1.75 cm	-1.75 cm
⁶ Li (%)	95.6	0.07	95.6	0.07
⁷ Li (%)	4.4	99.93	4.4	99.93
(g cm ⁻³)	2.54	2.64	2.54	2.64
Front shielding	none	none	4 mm boron loaded plastic plus 1 mm Al	4 mm boron loaded plastic plus 1 mm Al
Back shielding	2 mm boron loaded plastic	2 mm boron loaded plastic	none	none

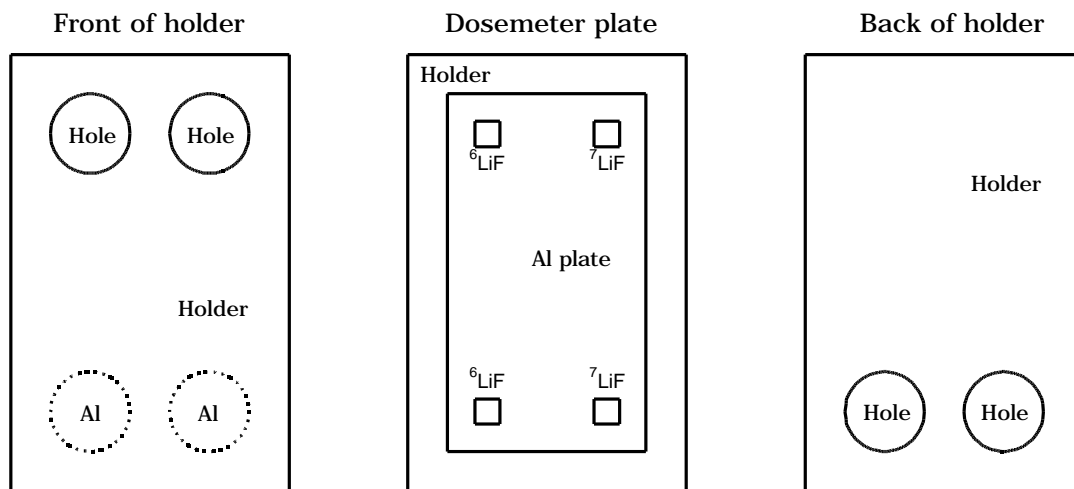

Figure 1 Slices through the dosimeter. From left to right, the front of the holder, the plate holding the TLD-chips, and the back of the holder. The aluminium discs in the front of the holder are depicted using broken lines because they are not as thick as the holder: there is 4 mm of holder material in front of them.

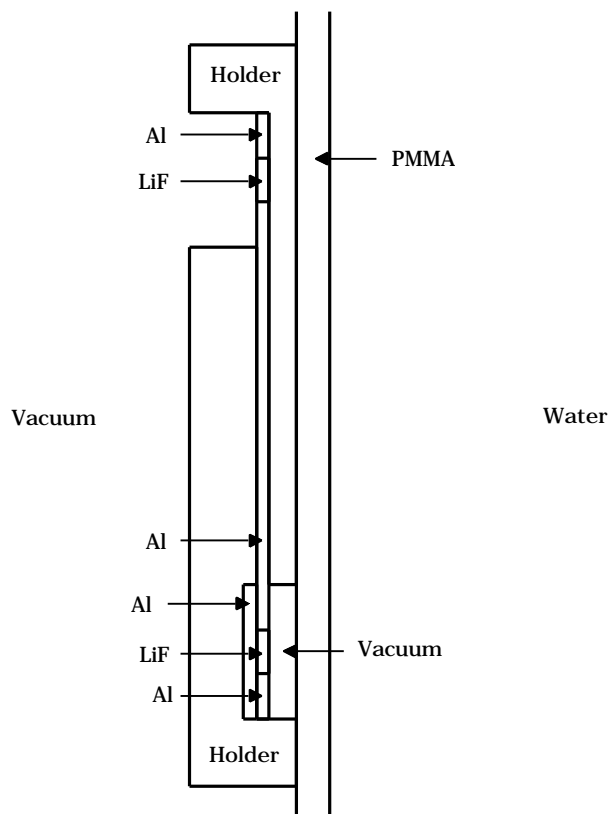

Figure 2 Slice through the dosimeter and phantom showing the LiF elements and their windows.

Materials

You should use the data for polymethyl methacrylate (PMMA), water and aluminium that are given in ICRU Publication 49. Lithium fluoride is also specified in that publication, but the materials used in this problem are isotopically enriched so those data do not apply here. The correct data for the lithium fluoride used in this problem are given in Table 2. Also given in Table 2 are data for the boron-loaded plastic holder material. This is designed to shield the TLD-elements from thermal neutrons. The data given are simply typical of boron loaded plastics and are not intended to refer to any commercial product.

Table 2 Material densities and elemental/isotopic weight fractions for all materials used in this problem

Material	PMMA	Water	⁶ LiF	⁷ LiF	Al	Holder
Hydrogen (natural)	0.080538	0.111894	-	-	-	0.080
Oxygen (natural)	0.319614	0.888106	-	-	-	-
Carbon (natural)	0.599848	-	-	-	-	0.635
⁶ Li	-	-	0.229	0.00016	-	-
⁷ Li	-	-	0.012	0.270	-	-
Fluorine (natural)	-	-	0.758	0.730	-	-
Boron (natural)	-	-	-	-	-	0.286
Aluminium (natural)	-	-	-	-	1.00	-
Density (g cm ⁻³)	1.19	1.00	2.54	2.64	2.70	1.19

Tasks

1. Determine the neutron response of the four elements at normal incidence for the following energies: 0.0253 eV, 1 eV, 10 eV, 100 eV, 1 keV, 10 keV, 100 keV, 1 MeV, 10 MeV and 20 MeV. Your results should be given as the number of ⁶Li(n, t)⁴He events per source neutron in each element.
2. Determine the photon response of the four elements for photon energies of 33 keV, 48 keV, 100 keV, 248 keV, 662 keV and 1.25 MeV. Your results should be given as the energy deposited per source photon.

Correspondence

If any of the above is unclear or misleading please contact Rick Tanner by e-mail at rick.tanner@nrpb.org. Enquiries will be dealt with as quickly as possible.

Results should be returned before 15 October 2002 to:

Dr R J Tanner
NRPB
Chilton
Didcot
Oxon OX11 0RQ
United Kingdom

P5. Air kerma backscatter profiles for two ISO photon expanded and aligned fields impinging on the ISO water phantom

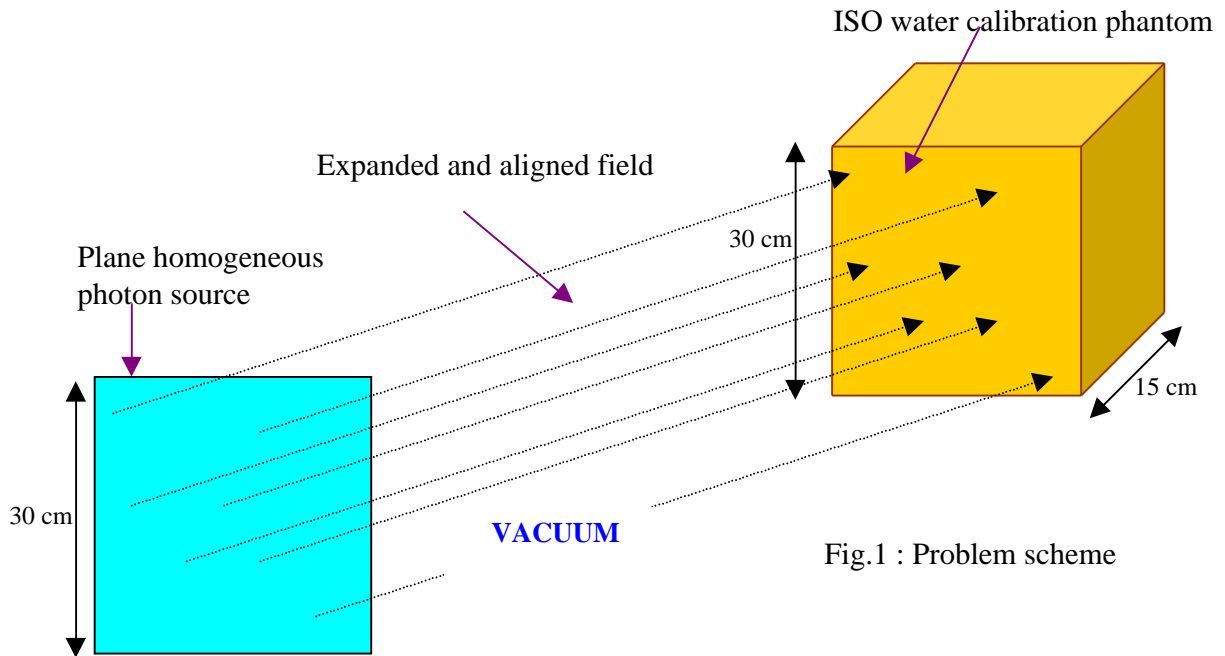

Fig.1 : Problem scheme

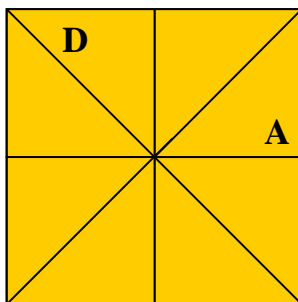

Fig. 2 : Air kerma backscatter profile mapping on the apothem (A) and diagonal (D) of the water phantom front face

An expanded and aligned field of photons is normally impinging on a ISO water calibration phantom. Two different sources are to be treated:

- 1) ISO Narrow Spectrum Series - tube voltage 200 kV (filtration 4.0 mm Al + 2.0 mm Cu + 3.0 mm Sn + 1.0 mm Pb)
- 2) ISO Wide Spectrum Series – tube voltage 150 kV (filtration 4.0 mm Al + 1.0 mm Sn)

Calculate:

- 1) The air kerma backscatter factor (**B**) at the centre of the phantom front face:

B = K_a (phantom present) / K_a (free in air) where $K_a = \int_{E_{min}}^{E_{max}} (E) \left(\frac{\mu_{tr}}{\rho} \right)_{air} E dE$ and K_a is defined in vacuum

- 2) The air kerma **B** profiles along the apothem and diagonal of the phantom front face.
- 3) The backscattered fluence spectrum in a central circular area on the phantom front face, where the variation of **B** is limited within –2% of the “maximum central value” (the source dimension should be the same as the phantom face dimension). The spectrum should be given in energy bins that are a multiple of 0.5 keV and should be normalised to 1 incident particle.
- 4) Optional: Evaluate the backscattered fluence spectrum dependence on the distance from the face center.

Problem Specifications:

WATER PHANTOM : a 30 x 30 x15 cm³ phantom with PMMA walls containing water
PMMA mass density = 1.19 g cm⁻³; elemental composition : H = 0.080538, C = 0.599848,
O = 0.319614 (fraction by weight)

Water mass density = 1.0 g cm⁻³; elemental composition : H = 0.111894, O = 0.888106 (fraction by weight)

The phantom walls have a thickness of 2.5 mm for the front face, and 10 mm for the remaining 5 cuboid faces.

Source specification:

Two expanded and aligned fields taken from two standard ISO series (Wide and Narrow).

The two spectra are given in figures 3 and 4.

The numerical values of the Probability Density Functions (PDF) of the spectra are given in Tables I and II (Given are the mean energies of the respective energy bins; they can be either used directly as discrete starting energies or as 0.5 keV energy bin histograms, or linearly interpolated to sample the source spectra).

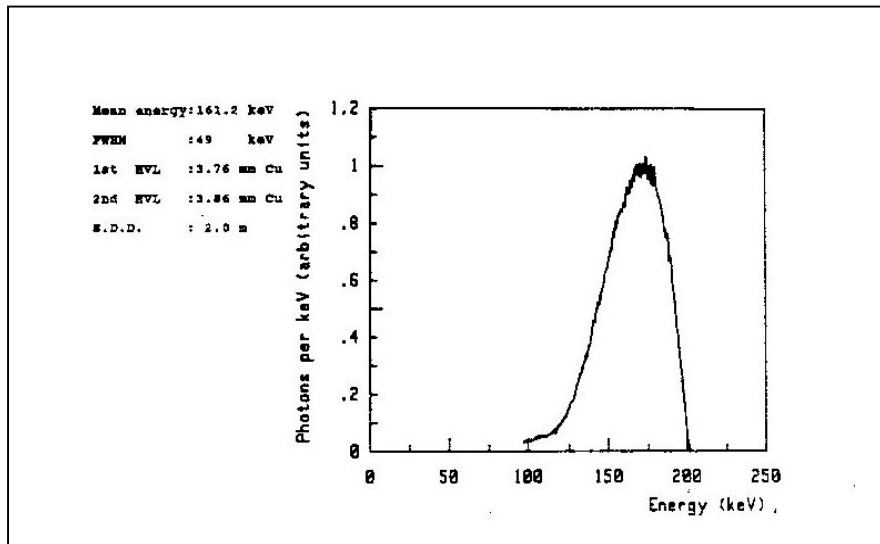

Fig.3: Narrow Spectrum Series (200 kV)

Data taken from:

R.F. Laitano et al. "Energy Distribution and Air Kerma Rates of ISO and BIPM Reference Filtered X-Radiations."
ENEA Report (Rome 1990)

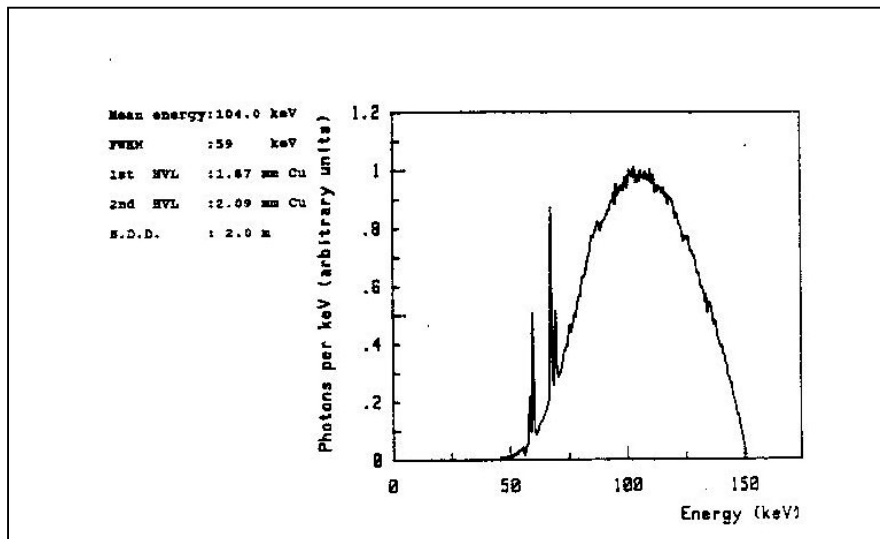

Fig.4: Wide Spectrum Series (150 kV)

Data taken from:

R.F. Laitano et al. "Energy Distribution and Air Kerma Rates of ISO and BIPM Reference Filtered X-Radiations."
ENEA Report (Rome 1990)

The results should be returned before 15 October 2002 to G. Gualdrini guald@bologna.enea.it
The PDF distributions are available on <http://members.aol.com/rprice1495/data/X-150kV> and
<http://members.aol.com/rprice1495/data/X-200kV>

Tab. I : Probability Density Function for the Narrow Spectrum 200 kV

Energy (MeV)	PDF(E)	Energy (MeV)	PDF(E)	Energy (MeV)	PDF(E)	Energy (MeV)	PDF(E)
1.030E-01	0.000E+00	1.280E-01	3.597E+00	1.530E-01	1.497E+01	1.780E-01	1.905E+01
1.035E-01	1.847E-01	1.285E-01	3.853E+00	1.535E-01	1.559E+01	1.785E-01	1.865E+01
1.040E-01	2.263E-01	1.290E-01	3.908E+00	1.540E-01	1.510E+01	1.790E-01	1.922E+01
1.045E-01	2.940E-01	1.295E-01	4.308E+00	1.545E-01	1.616E+01	1.795E-01	2.003E+01
1.050E-01	3.694E-01	1.300E-01	4.567E+00	1.550E-01	1.566E+01	1.800E-01	1.886E+01
1.055E-01	3.217E-01	1.305E-01	4.749E+00	1.555E-01	1.576E+01	1.805E-01	1.845E+01
1.060E-01	4.110E-01	1.310E-01	4.784E+00	1.560E-01	1.644E+01	1.810E-01	1.836E+01
1.065E-01	5.033E-01	1.315E-01	5.115E+00	1.565E-01	1.668E+01	1.815E-01	1.801E+01
1.070E-01	4.664E-01	1.320E-01	5.221E+00	1.570E-01	1.661E+01	1.820E-01	1.787E+01
1.075E-01	5.218E-01	1.325E-01	5.461E+00	1.575E-01	1.686E+01	1.825E-01	1.786E+01
1.080E-01	5.464E-01	1.330E-01	5.458E+00	1.580E-01	1.701E+01	1.830E-01	1.763E+01
1.085E-01	6.096E-01	1.335E-01	5.879E+00	1.585E-01	1.684E+01	1.835E-01	1.722E+01
1.090E-01	7.081E-01	1.340E-01	5.723E+00	1.590E-01	1.700E+01	1.840E-01	1.731E+01
1.095E-01	6.881E-01	1.345E-01	6.183E+00	1.595E-01	1.716E+01	1.845E-01	1.660E+01
1.100E-01	8.266E-01	1.350E-01	6.300E+00	1.600E-01	1.748E+01	1.850E-01	1.658E+01
1.105E-01	7.820E-01	1.355E-01	6.428E+00	1.605E-01	1.730E+01	1.855E-01	1.590E+01
1.110E-01	8.743E-01	1.360E-01	6.853E+00	1.610E-01	1.720E+01	1.860E-01	1.545E+01
1.115E-01	9.236E-01	1.365E-01	6.487E+00	1.615E-01	1.823E+01	1.865E-01	1.567E+01
1.120E-01	9.836E-01	1.370E-01	6.885E+00	1.620E-01	1.854E+01	1.870E-01	1.499E+01
1.125E-01	9.913E-01	1.375E-01	7.319E+00	1.625E-01	1.829E+01	1.875E-01	1.531E+01
1.130E-01	1.056E+00	1.380E-01	7.453E+00	1.630E-01	1.847E+01	1.880E-01	1.487E+01
1.135E-01	1.121E+00	1.385E-01	7.353E+00	1.635E-01	1.809E+01	1.885E-01	1.529E+01
1.140E-01	1.191E+00	1.390E-01	7.884E+00	1.640E-01	1.904E+01	1.890E-01	1.335E+01
1.145E-01	1.288E+00	1.395E-01	8.140E+00	1.645E-01	1.893E+01	1.895E-01	1.340E+01
1.150E-01	1.415E+00	1.400E-01	8.691E+00	1.650E-01	1.852E+01	1.900E-01	1.370E+01
1.155E-01	1.447E+00	1.405E-01	8.879E+00	1.655E-01	1.900E+01	1.905E-01	1.342E+01
1.160E-01	1.387E+00	1.410E-01	9.191E+00	1.660E-01	1.937E+01	1.910E-01	1.183E+01
1.165E-01	1.599E+00	1.415E-01	9.036E+00	1.665E-01	1.897E+01	1.915E-01	1.174E+01
1.170E-01	1.205E+00	1.420E-01	9.103E+00	1.670E-01	1.991E+01	1.920E-01	1.120E+01
1.175E-01	1.375E+00	1.425E-01	9.964E+00	1.675E-01	1.945E+01	1.925E-01	1.072E+01
1.180E-01	1.662E+00	1.430E-01	9.905E+00	1.680E-01	2.012E+01	1.930E-01	1.011E+01
1.185E-01	1.838E+00	1.435E-01	1.046E+01	1.685E-01	1.945E+01	1.935E-01	9.283E+00
1.190E-01	1.826E+00	1.440E-01	1.035E+01	1.690E-01	1.964E+01	1.940E-01	8.565E+00
1.195E-01	1.778E+00	1.445E-01	1.027E+01	1.695E-01	1.933E+01	1.945E-01	8.321E+00
1.200E-01	1.967E+00	1.450E-01	1.100E+01	1.700E-01	2.023E+01	1.950E-01	7.846E+00
1.205E-01	1.952E+00	1.455E-01	1.068E+01	1.705E-01	1.975E+01	1.955E-01	6.893E+00
1.210E-01	2.192E+00	1.460E-01	1.146E+01	1.710E-01	1.921E+01	1.960E-01	6.390E+00
1.215E-01	2.164E+00	1.465E-01	1.127E+01	1.715E-01	1.980E+01	1.965E-01	5.846E+00
1.220E-01	2.189E+00	1.470E-01	1.178E+01	1.720E-01	2.016E+01	1.970E-01	5.406E+00
1.225E-01	2.389E+00	1.475E-01	1.190E+01	1.725E-01	2.003E+01	1.975E-01	4.455E+00
1.230E-01	2.387E+00	1.480E-01	1.263E+01	1.730E-01	1.953E+01	1.980E-01	3.885E+00
1.235E-01	2.463E+00	1.485E-01	1.259E+01	1.735E-01	2.070E+01	1.985E-01	3.240E+00
1.240E-01	2.658E+00	1.490E-01	1.289E+01	1.740E-01	2.052E+01	1.990E-01	2.666E+00
1.245E-01	2.846E+00	1.495E-01	1.291E+01	1.745E-01	1.985E+01	1.995E-01	1.889E+00
1.250E-01	2.946E+00	1.500E-01	1.346E+01	1.750E-01	1.911E+01	2.000E-01	1.379E+00
1.255E-01	3.142E+00	1.505E-01	1.370E+01	1.755E-01	2.005E+01	2.005E-01	7.466E-01
1.260E-01	3.316E+00	1.510E-01	1.369E+01	1.760E-01	1.978E+01	2.010E-01	5.172E-01
1.265E-01	3.416E+00	1.515E-01	1.432E+01	1.765E-01	1.915E+01	2.015E-01	2.124E-01
1.270E-01	3.499E+00	1.520E-01	1.414E+01	1.770E-01	1.884E+01	2.020E-01	1.185E-01
1.275E-01	3.556E+00	1.525E-01	1.493E+01	1.775E-01	2.016E+01	2.025E-01	0.000E+00

Tab. II : Probability Density Function for the Wide Spectrum 150 kV

Energy (MeV)	PDF(E)	Energy (MeV)	PDF(E)	Energy (MeV)	PDF(E)	Energy (MeV)	PDF(E)
4.950E-02	0.000E+00	7.500E-02	7.592E+00	1.005E-01	1.607E+01	1.260E-01	1.311E+01
5.000E-02	3.499E-02	7.550E-02	8.027E+00	1.010E-01	1.646E+01	1.265E-01	1.325E+01
5.050E-02	1.400E-01	7.600E-02	7.546E+00	1.015E-01	1.717E+01	1.270E-01	1.261E+01
5.100E-02	2.682E-01	7.650E-02	7.887E+00	1.020E-01	1.692E+01	1.275E-01	1.232E+01
5.150E-02	2.566E-01	7.700E-02	8.257E+00	1.025E-01	1.687E+01	1.280E-01	1.240E+01
5.200E-02	3.324E-01	7.750E-02	8.671E+00	1.030E-01	1.672E+01	1.285E-01	1.209E+01
5.250E-02	2.828E-01	7.800E-02	8.470E+00	1.035E-01	1.735E+01	1.290E-01	1.205E+01
5.300E-02	4.403E-01	7.850E-02	9.120E+00	1.040E-01	1.700E+01	1.295E-01	1.173E+01
5.350E-02	3.645E-01	7.900E-02	9.584E+00	1.045E-01	1.637E+01	1.300E-01	1.105E+01
5.400E-02	5.569E-01	7.950E-02	9.750E+00	1.050E-01	1.649E+01	1.305E-01	1.112E+01
5.450E-02	5.802E-01	8.000E-02	9.695E+00	1.055E-01	1.685E+01	1.310E-01	1.106E+01
5.500E-02	6.181E-01	8.050E-02	1.067E+01	1.060E-01	1.646E+01	1.315E-01	1.048E+01
5.550E-02	7.464E-01	8.100E-02	1.089E+01	1.065E-01	1.714E+01	1.320E-01	1.020E+01
5.600E-02	2.391E-01	8.150E-02	1.086E+01	1.070E-01	1.670E+01	1.325E-01	1.019E+01
5.650E-02	3.528E-01	8.200E-02	1.106E+01	1.075E-01	1.673E+01	1.330E-01	9.910E+00
5.700E-02	8.281E-01	8.250E-02	1.144E+01	1.080E-01	1.667E+01	1.335E-01	9.339E+00
5.750E-02	9.359E-01	8.300E-02	1.201E+01	1.085E-01	1.706E+01	1.340E-01	9.823E+00
5.800E-02	2.429E+00	8.350E-02	1.213E+01	1.090E-01	1.658E+01	1.345E-01	8.709E+00
5.850E-02	3.770E+00	8.400E-02	1.242E+01	1.095E-01	1.674E+01	1.350E-01	9.339E+00
5.900E-02	1.639E+00	8.450E-02	1.327E+01	1.100E-01	1.650E+01	1.355E-01	9.321E+00
5.950E-02	8.730E+00	8.500E-02	1.320E+01	1.105E-01	1.721E+01	1.360E-01	9.097E+00
6.000E-02	4.828E+00	8.550E-02	1.316E+01	1.110E-01	1.641E+01	1.365E-01	8.744E+00
6.050E-02	1.662E+00	8.600E-02	1.358E+01	1.115E-01	1.636E+01	1.370E-01	7.957E+00
6.100E-02	1.458E+00	8.650E-02	1.355E+01	1.120E-01	1.686E+01	1.375E-01	8.208E+00
6.150E-02	1.621E+00	8.700E-02	1.397E+01	1.125E-01	1.581E+01	1.380E-01	8.193E+00
6.200E-02	1.735E+00	8.750E-02	1.415E+01	1.130E-01	1.626E+01	1.385E-01	7.228E+00
6.250E-02	2.114E+00	8.800E-02	1.387E+01	1.135E-01	1.588E+01	1.390E-01	7.178E+00
6.300E-02	2.271E+00	8.850E-02	1.358E+01	1.140E-01	1.622E+01	1.395E-01	6.770E+00
6.350E-02	2.315E+00	8.900E-02	1.385E+01	1.145E-01	1.616E+01	1.400E-01	6.613E+00
6.400E-02	2.417E+00	8.950E-02	1.413E+01	1.150E-01	1.603E+01	1.405E-01	6.779E+00
6.450E-02	2.618E+00	9.000E-02	1.417E+01	1.155E-01	1.578E+01	1.410E-01	6.199E+00
6.500E-02	2.846E+00	9.050E-02	1.426E+01	1.160E-01	1.613E+01	1.415E-01	6.202E+00
6.550E-02	3.032E+00	9.100E-02	1.458E+01	1.165E-01	1.561E+01	1.420E-01	5.645E+00
6.600E-02	3.373E+00	9.150E-02	1.450E+01	1.170E-01	1.556E+01	1.425E-01	5.584E+00
6.650E-02	3.598E+00	9.200E-02	1.483E+01	1.175E-01	1.579E+01	1.430E-01	4.895E+00
6.700E-02	7.779E+00	9.250E-02	1.479E+01	1.180E-01	1.509E+01	1.435E-01	4.858E+00
6.750E-02	1.499E+01	9.300E-02	1.527E+01	1.185E-01	1.560E+01	1.440E-01	4.493E+00
6.800E-02	6.173E+00	9.350E-02	1.525E+01	1.190E-01	1.548E+01	1.445E-01	4.502E+00
6.850E-02	4.388E+00	9.400E-02	1.538E+01	1.195E-01	1.545E+01	1.450E-01	3.869E+00
6.900E-02	6.537E+00	9.450E-02	1.582E+01	1.200E-01	1.526E+01	1.455E-01	3.630E+00
6.950E-02	8.852E+00	9.500E-02	1.510E+01	1.205E-01	1.479E+01	1.460E-01	3.376E+00
7.000E-02	5.467E+00	9.550E-02	1.634E+01	1.210E-01	1.430E+01	1.465E-01	3.015E+00
7.050E-02	4.881E+00	9.600E-02	1.599E+01	1.215E-01	1.460E+01	1.470E-01	2.607E+00
7.100E-02	5.079E+00	9.650E-02	1.564E+01	1.220E-01	1.455E+01	1.475E-01	2.598E+00
7.150E-02	5.155E+00	9.700E-02	1.575E+01	1.225E-01	1.396E+01	1.480E-01	2.003E+00
7.200E-02	5.502E+00	9.750E-02	1.601E+01	1.230E-01	1.393E+01	1.485E-01	1.691E+00
7.250E-02	5.992E+00	9.800E-02	1.621E+01	1.235E-01	1.372E+01	1.490E-01	1.420E+00
7.300E-02	6.528E+00	9.850E-02	1.599E+01	1.240E-01	1.329E+01	1.495E-01	1.079E+00
7.350E-02	6.485E+00	9.900E-02	1.596E+01	1.245E-01	1.293E+01	1.500E-01	6.677E-01
7.400E-02	6.817E+00	9.950E-02	1.653E+01	1.250E-01	1.329E+01	1.505E-01	2.712E-01
7.450E-02	6.750E+00	1.000E-01	1.674E+01	1.255E-01	1.309E+01	1.510E-01	0.000E+00

P6. Calibration of neutron detectors in a bunker

Introduction

Neutron fields produced in a target or by fission sources such as ^{252}Cf are perturbed by interactions with matter. Consider a ^{252}Cf fission source placed in the centre of a small bunker room. The perturbations stem then from the encapsulation of the source, positioning gears (holders), air and the walls. Shadow cones are designed to suppress direct contributions from the source and, as a result, enable (some) of these perturbations to be determined experimentally. They also provide means to realise neutron calibration fields (also called "realistic" neutron fields) which may replicate rather closely some of the workplace radiation fields. However, in-scatter from the cone and partial shielding of the in-scatter from air cannot be avoided. Calculations are therefore needed to correctly estimate the various contributions to fluence at the site of detectors to be calibrated. A special problem is posed by the composition of the concrete bunker walls as the albedo from these walls depends strongly on the hydrogen content in concrete.

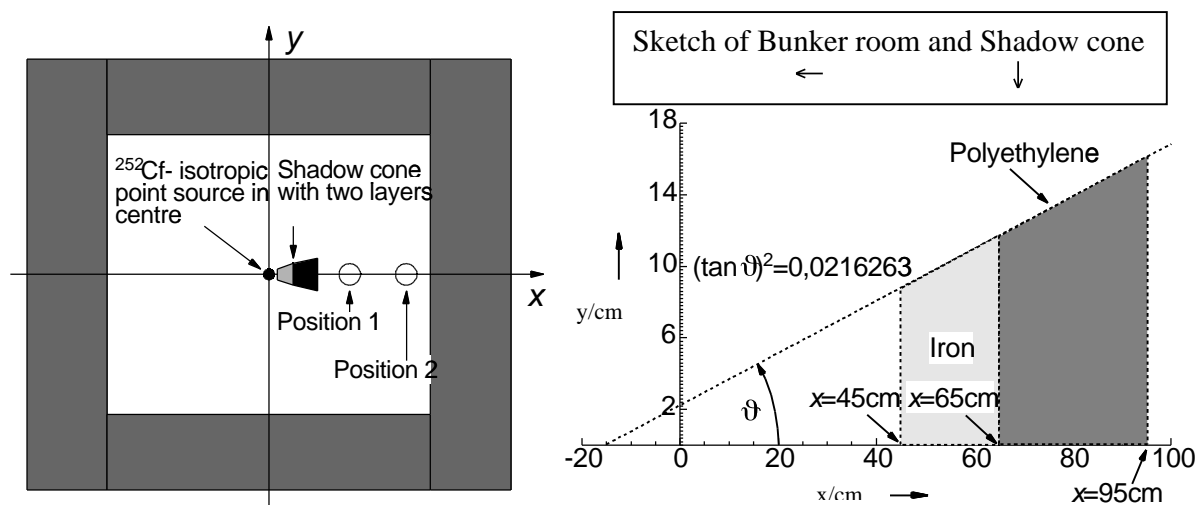

In the centre of a so-called *bunker* room with concrete wall is an isotropic ^{252}Cf neutron source against which a detector in position 1 or 2 is to be calibrated. Two measurements are taken, one with and one without a shadow cone. The difference spectrum is close to that which would be obtained in free-in-air measurements ("shadow cone" technique). When a calibration in the so-called realistic neutron fields is performed, one measurement is taken with the instrument under test placed at a characterised position, and one with the shadow cone.

Proposed tasks

In order to avoid unwanted variance in the set-up, all material input data, the energy distribution of the isotropic source, the dimensions and positions of the walls, of the shadow cone and detectors are given below and ENDF/VI neutron cross section are recommended.

The proposed tasks have to be calculated in the presence of the shadow cone:

- (1) the distribution of neutron fluence in **energy** at the detector positions 1 and 2
- (2) the contribution to the neutron spectral fluence from different directions at the detector positions 1 and 2
- (3) the **contributions** to the above mentioned distributions from **air** and the **walls** (on the side of the sensors and opposite, side walls, floor and ceiling)
- (4) the influence of a change in the **water content** in concrete.
(the last task is on purpose vaguely formulated, please explain your approach.)

Please do not worry if you have not the time to solve all four problems. E.g. you may skip the second sensor or address only a subset of the problems stated.

Detailed specifications for the calibration room problem

A) Energy distribution of the bare ^{252}Cf isotropic source:

The source is a cylinder, diameter 0.5 cm, height 0.5 cm, with its geometrical centre in the centre of the room. Self-shielding of this volume source is neglected.

For a more convenient form of the following data (ISO 8529-1 Cf (2001)) see page 27.

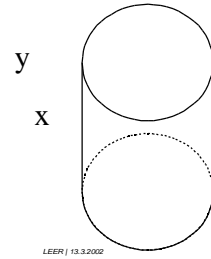

Table 1 – Energy distribution of the ^{252}Cf neutron source (ISO 8529-1 Cf (2001)). E_n is the upper limit of the energy bin.

Bin	E_n/MeV	weight	Bin	E_n/MeV	weight	Bin	E_n/MeV	weight
1	4.14E-7	0.00E+0	19	2.0E-1	1.21E-2	37	2.3	6.55E-2
2	1.0E-6	0.31E-9	20	2.5E-1	1.33E-2	38	2.6	5.67E-2
3	1.0E-5	1.11E-8	21	3.0E-1	1.42E-2	39	3.0	6.33E-2
4	5.0E-5	1.27E-7	22	3.5E-1	1.49E-2	40	3.5	6.21E-2
5	1.0E-4	2.76E-7	23	4.0E-1	1.55E-2	41	4.0	4.68E-2
6	2.0E-4	7.82E-7	24	4.5E-1	1.60E-2	42	4.5	3.49E-2
7	4.0E-4	2.21E-6	25	5.0E-1	1.63E-2	43	5.0	2.58E-2
8	7.0E-4	4.53E-6	26	5.5E-1	1.66E-2	44	6.0	3.30E-2
9	1.0E-3	5.68E-6	27	6.0E-1	1.68E-2	45	7.0	1.74E-2
10	3.0E-3	5.51E-6	28	7.0E-1	3.38E-2	46	8.0	9.01E-3
11	6.0E-3	1.28E-4	29	8.0E-1	3.39E-2	47	9.0	4.61E-3
12	1.0E-2	2.30E-4	30	9.0E-1	3.37E-2	48	1.0E+1	2.33E-3
13	2.0E-2	7.74E-4	31	1.0	3.33E-2	49	1.1E+1	1.17E-3
14	4.0E-2	2.17E-3	32	1.2	6.46E-2	50	1.2E+1	5.83E-4
15	6.0E-2	2.80E-3	33	1.4	6.12E-2	51	1.3E+1	2.88E-4
16	8.0E-2	3.29E-3	34	1.6	5.73E-2	52	1.4E+1	1.42E-4
17	1.0E-1	3.68E-3	35	1.8	5.31E-2	53	1.5E+1	6.94E-5
18	1.5E-1	1.05E-2	36	2.0	4.88E-2	54	1.6E+1	0.00E+0

B) Geometry:

The **room** inside the bunker is encompassed by the planes $x = -350$ cm and $x = 350$ cm \leftrightarrow $y = -350$ cm and $y = 350$ cm \leftrightarrow $z = -325$ cm and $z = 325$ cm. The thickness of the **concrete walls** is 50 cm.

The **shadow cone** extends between the $x = 45.0$ cm and $x = 95.0$ planes; the $x = 65.0$ -plane separates **iron** (closer to source) and **polyethylene** (closer to wall). The top of the cone containing the shadow cone is at $x = -15.0$ cm, the axis of the cone coincides with the x-axis. The cone is described for $x > -15$ cm by: $(y^2+z^2)^{1/2} = (0.0216263)^{1/2}*(x+15.0)$. (e.g. **MCNP description**: KX -15.0 2.16263E-2 +1)

C) Materials:

(compositions are taken from ICRU Report 49)

The density of the **concrete** is 2.3 g cm^{-3} and the atomic percentages are: 11.7% H, 60.82% O and 27.48% Si. If you vary the H₂O content (task 4), please keep the density constant at 2.3 g cm^{-3} , e.g. +1% H₂O H = 13.38%, O = 59.98%, Si = 26.64%.

The **room** is filled with **air**, density $1.20484 \times 10^{-3} \text{ g cm}^{-3}$, and the weight percentages are: 0.0125 % C, 75.5267 % N, 23.1781% O and 1.2827% Ar

The **shadow cone** consists of **natural iron**, the density is 7.87 g cm^{-3} and **polyethylene**, i.e.(CH₂)_n, with a density of 0.94 g cm^{-3} .

D) Detectors and Tallies

position 1 = (x= 170 cm, y = 0 cm, z = 0 cm) and **position 2** = (x= 300 cm, y = 0 cm, z = 0 cm)

To keep the evaluation manageable, please use the energy bins for which the source spectrum is specified.

To keep the evaluation manageable, please use the following cosine-bins for calculating the contribution to the spectral fluences from different directions:

[-1.0,-0.866], [-0.866,-0.5], [-0.5,0.0], [0.0,0.5], [0.5,0.866] and [0.866,1]. These bin-boundaries correspond to 0°, 30°, 60°, 90°, 120°, 150° and 180°. It is up to you to calculate spectra below cut-off (0.4 eV)

It is part of the task that you select appropriate tallying and details of the detector geometry. Please comment on your choice.

E) How to present the results

Please give the results in *tabular and graphical* form. Please provide ASCII-text files for the tables.

F) Energy distribution of the bare ²⁵²Cf isotropic source:

(ISO 8529-1 Cf (2001))

Energies (upper bin boundary):

4.14E-7	1.0E-6	1.0E-5	5.0E-5	1.0E-4	2.0E-4	4.0E-4	7.0E-4	1.0E-3
3.0E-3	6.0E-3	1.0E-2	2.0E-2	4.0E-2	6.0E-2	8.0E-2	1.0E-1	1.5E-1
2.0E-1	2.5E-1	3.0E-1	3.5E-1	4.0E-1	4.5E-1	5.0E-1	5.5E-1	6.0E-1
7.0E-1	8.0E-1	9.0E-1	1.0	1.2	1.4	1.6	1.8	2.0
2.3	2.6	3.0	3.5	4.0	4.5	5.0	6.0	7.0
8.0	9.0	10.0	11.0	12.0	13.0	14.0	15.0	16.0

Probabilities:

0.00E+0	0.31E-9	1.11E-8	1.27E-7	2.76E-7	7.82E-7	2.21E-6	4.53E-6	5.68E-6	5.51E-6	1.28E-4
2.30E-4	7.74E-4	2.17E-3	2.80E-3	3.29E-3	3.68E-3	1.05E-2	1.21E-2	1.33E-2	1.42E-2	1.49E-2
1.55E-2	1.60E-2	1.63E-2	1.66E-2	1.68E-2	3.38E-2	3.39E-2	3.37E-2	3.33E-2	6.46E-2	6.12E-2
5.73E-2	5.31E-2	4.88E-2	6.55E-2	5.67E-2	6.33E-2	6.21E-2	4.68E-2	3.49E-2	2.58E-2	3.30E-2
1.74E-2	9.01E-3	4.61E-3	2.33E-3	1.17E-3	5.83E-4	2.88E-4	1.42E-4	6.94E-5	0.00E+0	

If there are questions on this problem or if you need data in electronic form please contact:

molou@club-internet.fr (Jean-Louis Chartier) or Bernd.Siebert@ptb.de .

Correspondence

Results should be returned before 15 October 2002 to:

Dr B.R.L. Siebert

PTB

Bundesallee 100

D38023 Braunschweig, Germany

E-mail : bernd.siebert@ptb.de

P7. Peak efficiencies and pulse height distributions of a photon germanium spectrometer in the energy range below 1 MeV

Problem :

Depending on the applications in which photon germanium spectrometers are used, two correlated characteristics are quite essential. When the determination of radionuclides and their activity in materials is aimed at, the knowledge of the peak efficiency over a specific energy range is required, whereas the fluence spectrum (and dose) determination is derived from unfolding procedures based on an array of pulse height distributions (or response functions) denoted the response matrix. However the measurements of those characteristics can only be performed at a limited number of energies and, in addition, experimental results are generally distorted by parasitic contributions of radiation scattering in the materials of the source and detector surroundings. Alternatively, Monte-Carlo simulations of the particle transport in the detector may be used to provide a full set of response functions with a good accuracy when the physical characteristics of the detector and its environment can be reliably defined, i.e. detector and dead layers dimensions, holder, cryostat Al cap, etc. In this problem, this computational approach and an estimation of the uncertainty associated to the results are considered.

Geometry :

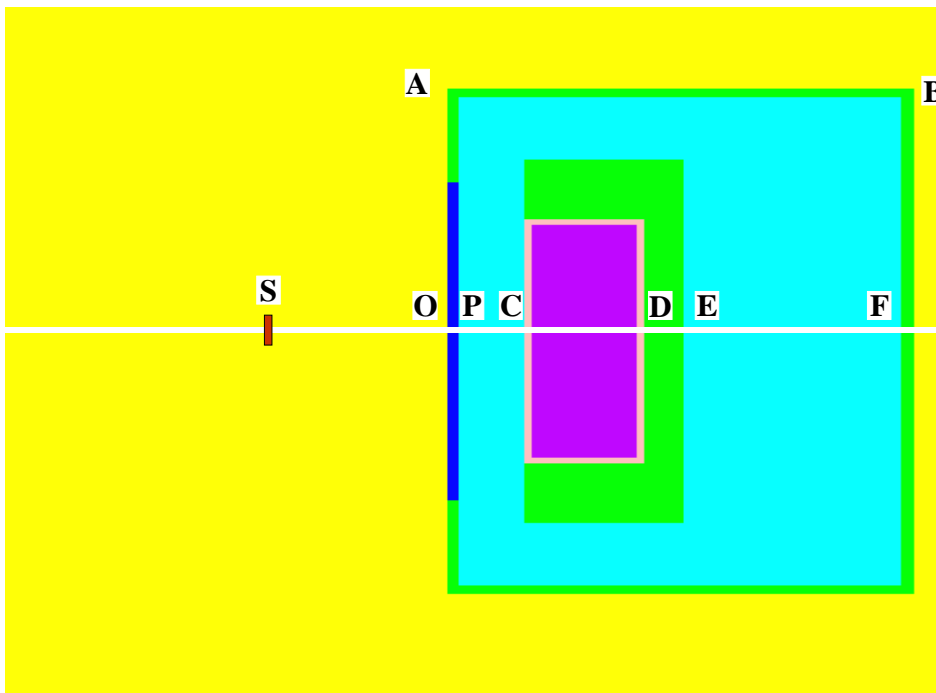

- An isotropic photon source S is placed in air, in front of a germanium spectrometer installed in a cryostat (vacuum)
- The set up is axially symmetrical and the sketch above represents a longitudinal section.
- The germanium detector is partially embedded in an Al holder.
- Dead layers (not to scale) below the surfaces of the Ge are to be considered.
- The energy resolution of the detector should be taken into account

Proposed tasks :

1) Computational determinations of detector peak efficiencies and pulse height distributions at 15 keV, 30 keV, 60 keV, 100 keV, 0.25 MeV, 0.5 MeV, 0.75 MeV and 1 MeV.

The detector peak efficiency is defined as the number of events in the full-energy peak per emitted particle.

In order to get an appropriate representation of the full-energy peak, you are recommended to select an energy binning structure for the pulse height distribution compatible with the energy resolution of the spectrometer.

2) Estimation of the overall uncertainty associated to the peak efficiencies and pulse height distributions after investigating the influence of some sources of uncertainties (dead layers thickness, source and spectrometer positionings, ...) for the energies quoted in 1)

3) (optional) Estimation of the influence of the Al holder on the peak efficiencies and the pulse height distributions at the same photon energies as in 1)

4) (optional) Calculate the peak efficiencies and the pulse height distributions when the symmetry axis of the spectrometer assembly makes an angle of 15°, 30° or 60° with the source axis, at one of the following energies: 30 keV, 100 keV, 0.25 MeV and 1 MeV. The rotation axis is perpendicular in O to the section as shown in the sketch above.

Dimensions and other data :

- Source: disk (radius = 2.5 mm) ; distance source – Be window front surface : SO = 20 mm

- Cryostat (cylinder): Al thickness=1.5 mm; external radius OA=41.5 mm; total height AB = 58 mm

- Ge detector (**dead layers are included**): outer radius = 20 mm ; height CD = 15 mm

- Dead layers: thickness = 0.1 mm

The dead layers surround the Ge core of the detector (core: Ge cylinder, radius=19.9 mm, height = 14.8 mm)

- front Ge dead layer: cylinder radius = 20 mm, height = 0.1 mm

- back Ge dead layer: cylinder radius = 20 mm, height = 0.1 mm

- lateral Ge dead layer: zone between two cylinders having respectively a radius of 19.9 mm and 20 mm and a height of 14.8 mm.

- Al detector holder: 2 parts

a) back part of the holder: cylinder; radius = 30 mm and height = 5 mm

b) lateral part of the holder: outer radius = 30 mm, inner radius = 20 mm, height = 15 mm

- Be window: cylinder; radius = 26 mm; height OP = 1.5 mm

- Distance from the Be window rear surface to the Ge detector front surface: PC = 5 mm

- Distance from the Al holder rear surface to the cryostat inner rear surface: EF = 30 mm

- Estimated uncertainty of dead layers thickness: $\pm 50\%$

- Estimated uncertainty of source positioning: ± 0.5 mm along the figure axis
- Estimated uncertainty of the spectrometer angular positioning: $\pm 2^\circ$
- Detector resolution (FWHM = \sqrt{E})
 - a) $E_1 = 0.5$ keV at 5.9 keV ; $E_2 = 1$ keV at 122 keV ; $E_3 = 2.5$ keV at 1332 keV
 - b) Fitting function: E (MeV) = $3.592 \cdot 10^{-4} + 1.832 \cdot 10^{-3} \cdot \sqrt{E + 0.01918E^2}$, with E in MeV.
- Air composition (weight percentage) : O (23.1781%), N (75.5267%), C (0.0125%), Ar (1.2827%)
 - $\rho_{\text{air}} = 1.20484 \cdot 10^{-3} \text{ g cm}^{-3}$
 - $\rho_{\text{Ge}} = 5.323 \text{ g cm}^{-3}$

Presentation of results :

In the energy range below 1 MeV, the shapes of the Ge spectrometer pulse height distributions (P.H.D) (or response functions) are strongly dependent on the incident photon energy. Therefore the analysis of results will be performed on the basis of several features of response functions (R.F.). In particular, several energy regions, which can be defined in relation with specific structures of R.F., are representative of the radiation interaction processes in such a detector, for instance, the Compton edge, the total energy absorption peak (or photopeak), the backscattered photon edge, etc. An example is shown below.

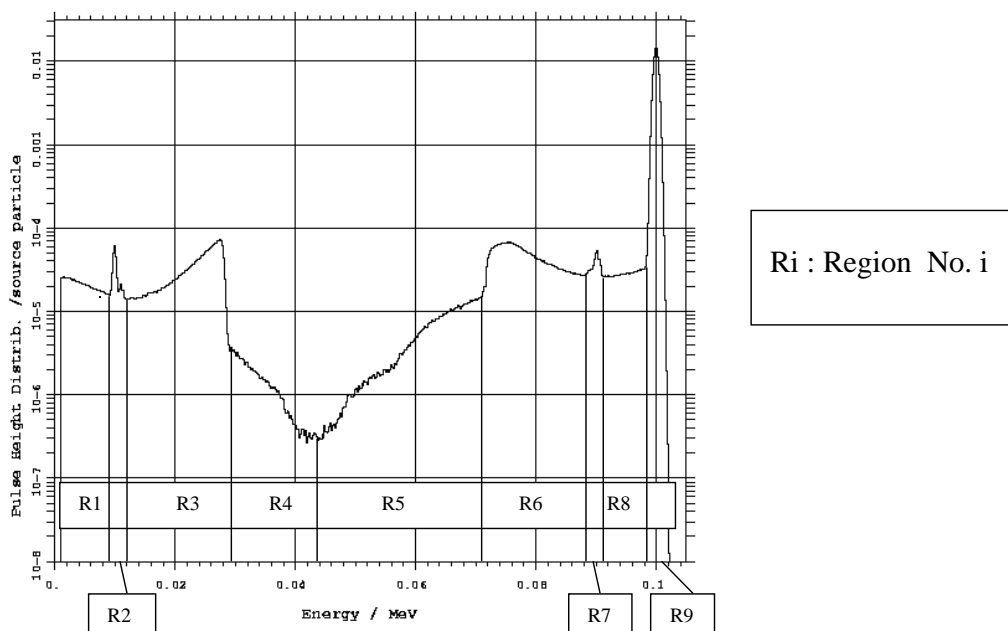

In order to make easier the evaluation of results thanks to a good homogeneity of presentations, the participants are asked to provide their results on hard copy (graphs, tables), on CD or diskette (R.F. histogram ASCII files) and/or via E-mail.

a) R.F.histogram: (ASCII file)

Energy (MeV)	P.H.D. in energy bin E	Precision
2.0E-03
2.2E-03	2.50325E-05	0.0093
2.4E-03	2.50428E-05	0.0092
2.6E-03	2.45322E-05	0.0093
2.8E-03	2.41611E-05	0.0094
3.0E-03

Note 1 : 2.50325E-05 is the content of the energy bin E (lower limit: 2.0E-03 MeV; upper limit: 2.2E-03 MeV) with the precision 0.0093,

2.50428E-05 is the content of the energy bin E (lower limit: 2.2E-03 MeV; upper limit: 2.4E-03 MeV) with the precision 0.0092, etc.

Note 2 : It is reminded that all results should be normalised to 1 particle emitted by the source.

b) R.F. graph (Postscript or Word file)

Abscissa in linear scale (lower limit: 0 ; upper limit: $1.05E_0$, E_0 = incident photon energy)

Ordinate in logarithmic scale (see recommended limits in Table 1)

c) R.F. : integral and standard deviation of the P.H.D.,

d) Photopeak (including K-escape peak) : integral and standard deviation,

e) For each energy region : integral and standard deviation,

Examples of energy limits assigned to the R.F. regions are given in the Table 1.

For each pulse height distribution, the presentation of the results of items c), d) and e) in a table is recommended.

Table 1

Incident photon energy (keV)	Limits of ordinate Scale	Examples of energy regions
		(keV)
15	10^{-9} to 2.10^{-3}	1.0-2.4;2.4-6.8;6.8-13.2;13.2-16.4
30	10^{-8} to 3.10^{-2}	1.0-4.2;4.2-9.0;9.0-14.8;14.8-22.4;22.4-29.0;29.0-31.6
60	10^{-8} to 3.10^{-2}	1.0-12.0;12.0-24.0;24.0-48.0;48.0-55.0;55.0-58.0;58.0-62.0
100	10^{-8} to 3.10^{-2}	1.0-9.2;9.2-11.6;11.6-29.2;29.2-44.0;44.0-71.0;71.0-88.0;88.0-92.0;92.0-97.0;97.0-102.2
250	10^{-7} to 10^{-2}	1.0-125.0;125.0-238.0;238.0-243.0;243.0-247.0;247.0-253.0
500	10^{-7} to 3.10^{-3}	2.0-168.0;168.0-332.0;332.0-488.0;488.0-495.0;495.0-504.0
750	10^{-7} to 3.10^{-3}	2.0-190.0;190.0-562.0;562.0-737.0;737.0-746.0;746.0-755.0
1000	10^{-7} to 3.10^{-3}	3.0-202.5;202.5-801.0;801.0-987.0;987.0-996.0;996.0-1,005.0

Correspondence:

Results should be returned before 15 October 2002 to:

Dr. Stéphanie Ménard

C.E. Fontenay-aux-Roses

IRSN/DPHD/SDOS/LRDE

Rue Auguste Lemaitre

BP 17 (92265) Fontenay-aux-Roses Cedex

France

E_mail address: stephanie.menard@irsn.fr

P8. Constancy check source

Problem :

The calibration factor, N , of a radiation measuring device, as determined in a reference laboratory, is strictly valid at the time of the calibration. Before and after any later measurement performed with that instrument, it is important to verify that the numerical value of N has not changed. A simple means to perform such a check is to realise a set-up enabling a reproducible positioning of the device with respect to a radioactive source. If that condition is fulfilled, then the ratio M/N , in which M is the indication/reading of the device, should be constant, after having applied the correction for the half-life decay of the radionuclide.

In this problem, the case of a neutron measuring device, basically a polyethylene sphere with a spherical proportional ^3He counter placed at the geometrical centre, is considered. The purpose is to investigate the uncertainties on the positionings of the instrument and the radioactive source which can be tolerated to envisage a satisfactory use of that technique, or in other words, which are responsible for a negligible uncertainty contribution to M .

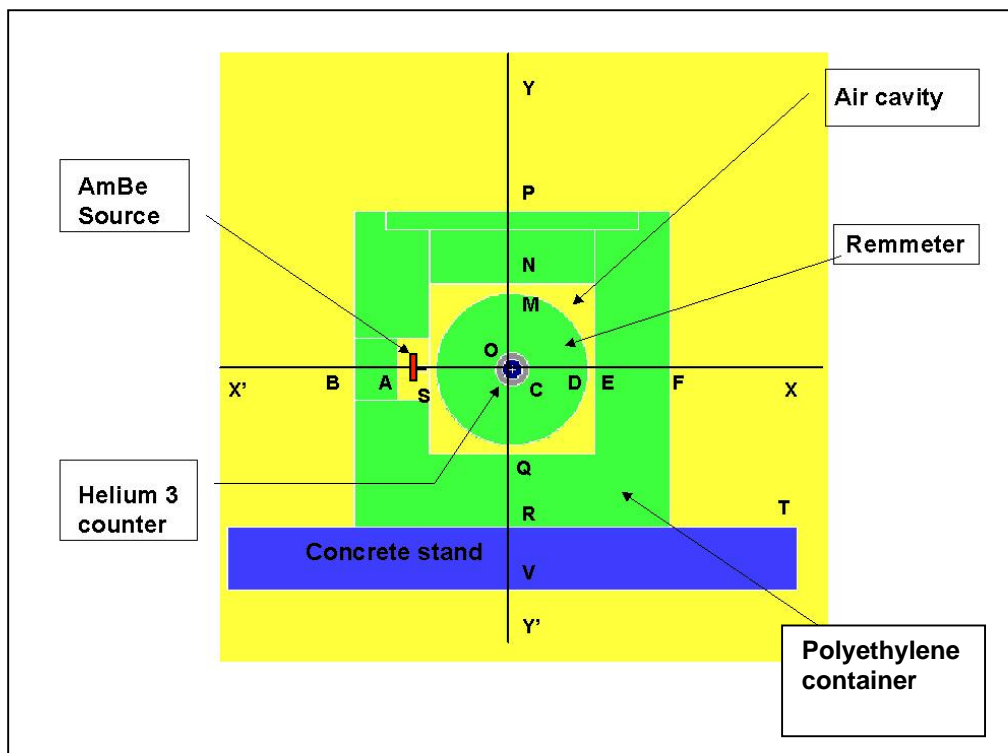

Geometry:

The sketch above (not to scale) shows a section in the plane of symmetry of the assembly, including a measuring device under test. The set-up consists of:

- a cylindrical polyethylene $(\text{CH}_2)_n$ container and its central cylindrical cavity, with $Y'OY$ as a symmetry axis. O is the geometrical centre of the cavity.

- a simplified rem-meter composed of a $(\text{CH}_2)_n$ sphere with a spherical proportional ^3He counter at its geometrical centre, in coincidence with O.
- a cylindrical $^{241}\text{AmBe}$ source S, such as its symmetry axis $X'\text{SOX}$ is perpendicular to $Y'\text{OY}$.
- a cylindrical concrete stand, with $Y'\text{OY}$ as symmetry axis.

The set-up is placed in air.

Air composition in weight fraction (ICRU Report 49)

- N (0.755267); O (0.231781); Ar (0.012827); C(0.000125)
- $\rho_{\text{air}} = 1.20484 \cdot 10^{-3} \text{ g cm}^{-3}$

Note 1: The air cavity containing the source (or “source cavity”) is an air cylinder (axis $X'X$), limited by 2 cylindrical end-surfaces (axis $Y'Y$).

Note 2 : The $(\text{CH}_2)_n$ plug placed behind the source (or “source plug”) is a $(\text{CH}_2)_n$ cylinder (axis $X'X$) limited by 2 cylindrical end-surfaces (axis $Y'Y$).

The ”source cavity” and the “source plug” have a party end-surface intercepting $X'X$ at A.

Dimensions and other data :

1) $(\text{CH}_2)_n$ container

- outer radius $OF = 20 \text{ cm}$
- inner radius $OE = 13 \text{ cm}$
- upper wall thickness $NP = 7 \text{ cm}$
- lower wall thickness $QR = 7 \text{ cm}$
- instrument air cavity : height $QN = 26 \text{ cm}$ with $ON = OQ$
- polyethylene $= 0.94 \text{ g cm}^{-3}$

2) neutron measuring device

- central ^3He detector
- spherical shell:
 - outer radius = 1.65 cm
 - inner radius = 1.60 cm
 - filling gas : ^3He , pressure = 200 kPa
- $\rho_{\text{iron}} = 7.87 \text{ g cm}^{-3}$
- $(\text{CH}_2)_n$ sphere : radius $OD = 12.5 \text{ cm}$

3) $^{241}\text{AmBe}$ neutron source

- volume source, isotropic emission, no autoabsorption
- cylindrical shape (axis $X'\text{OX}$), geometrical centre S such as $OS = 14 \text{ cm}$
- source radius = 0.5 cm; height = 1 cm
- emission spectrum: ISO Standard 8529-1 (2001) Annex A – data available on <http://members.aol.com/rprice1495/data/AmBe>

4) additional data concerning the “source cavity” and the “ source plug”

- cylindrical shape (axis $X'\text{OX}$)
- radius = 2.5 cm
- end-surfaces of the “source plug”
 - cylindrical shapes (axis $Y'\text{OY}$)
 - inner surface radius $OA = 15 \text{ cm}$
 - outer surface radius $OB = 20 \text{ cm}$ (= container outer radius OF , see 1) above)

5) concrete stand

- cylinder (axis Y'Y)
 - radius RT = 45 cm
 - height RV = 10 cm
- concrete composition (atomic fraction)
 - H (0.1170) O (0.6082) Si (0.2748)
- $\rho_{\text{concrete}} = 2.3 \text{ g cm}^{-3}$

Proposed tasks :

Preliminary remarks : It is assumed that the indication of the neutron device is represented by the number of neutron absorption interactions in the filling gas of the counter, mainly (n,p) interactions.

Results of calculations should be normalised to one emitted source particle.

“Reference conditions” (RC) are those for which :

- the geometrical centres of the container cavity and the neutron device are in coincidence in O,
- the distance from O to the geometrical source centre is OS = 14 cm.

1) Determination of the neutron fluence spectrum in the ^3He counter in (RC).

2) Determination of the indication of the neutron measuring instrument in (RC).

3) Estimate the contribution of the concrete stand to the indication of the instrument under test. What are the consequences?

4) It is generally agreed that, in the best conditions, the overall uncertainty assigned to the calibration factor N of a neutron measuring device cannot be lower than 2% (for instance with ^{252}Cf neutron source). Consequently, the uncertainty contribution of the source constancy check should be negligible with respect to that value by assuming a quadratic composition of uncertainties. It is also established that the main causes of uncertainty derive from a lack of reproducibility in the positionings of the instrument and the source.

* (Optional) If the RC positioning uncertainties are $\pm 1 \text{ mm}$ and $\pm 0.5 \text{ mm}$ for the instrument and the ($^{241}\text{AmBe}$) source respectively, are those specifications compatible with a satisfactory and reliable use of the check source set-up when a total uncertainty of 0.5% on the instrument indication is required ?

Note: To simplify the uncertainty analysis, it will be assumed, when dealing with the lack of precision in the positioning processes, that the instrument and the ($^{241}\text{AmBe}$) source can only shift along the X'OX direction.

Presentation of results:

1) Identification of the participant

Name:

Institution:

Address:

E_mail address:

Phone:

Fax:

Code used and version number:

Variance reduction methods applied:

2) Neutron fluence spectrum in the ^3He counter in "reference conditions" (RC). See above.

- Integral fluence, precision
- Neutron fluence spectrum per lethargy unit (histogram ASCII file)
Semi-log graph
- Number of histories

3) Indication of the neutron device (RC).

- Integral of (n,p) interactions in the ^3He counter, precision
- Distribution of (n,p) interactions as a function of neutron energy (histogram ASCII file)
Log-log graph
- Number of histories

4) Relative contribution of the concrete stand to the instrument indication, in %.

- Precision, number of histories
- Consequences

5) *(Optional) Relative variation of the instrument indication due to the instrument positioning uncertainty, in %.

- Precision, number of histories
- Consequences

6) *(Optional) Relative variation of the instrument indication due to the source positioning uncertainty, in %.

- Precision, number of histories
- Consequences

Correspondence:

Results should be returned before 15 October 2002 to:

Dr. Stéphanie Ménard

C.E. Fontenay-aux-Roses

IRSN/DPHD/SDOS/LRDE

Rue Auguste Lemaitre

BP 17 (92265) Fontenay-aux-Roses Cedex

France

E_mail address: stephanie.menard@ipsn.fr