

Unclassified

NEA/NSC/DOC(2003)13

Organisation de Coopération et de Développement Économiques
Organisation for Economic Co-operation and Development

31-Mar-2008

English - Or. English

**NUCLEAR ENERGY AGENCY
NUCLEAR SCIENCE COMMITTEE**

Cancels & replaces the same document of 28 May 2003

**OECD/NRC BENCHMARK BASED ON NUPEC BWR
FULL-SIZE FINE-MESH BUNDLE TESTS (BFBT)**

Proposal

JT03243246

Document complet disponible sur OLIS dans son format d'origine
Complete document available on OLIS in its original format



**NEA/NSC/DOC(2003)13
Unclassified**

English - Or. English

**OECD/NRC Benchmark based on NUPEC BWR
Full-size Fine-mesh Bundle Tests (BFBT)**

PROPOSAL

Revised on 21 May 2003

TABLE OF CONTENTS

Summary.....	3
1. Introduction.....	5
2. Summary of NUPEC BWR full-size fine-mesh bundle test.....	6
2.1 BWR rod bundle void distribution measurement	6
2.1.1 Test facility.....	6
2.1.2 Void fraction measurement methods.....	9
2.1.3 Test conditions.....	10
2.2 BWR critical power measurement.....	11
2.2.1 Test facility.....	11
2.2.2 Critical power measurement methods.....	11
2.2.3 Test conditions.....	14
3. Proposal of benchmark problems.....	15
3.1 Void distribution benchmark.....	16
3.1.1 Steady-state sub-channel grade benchmark.....	16
3.1.2 Steady-state microscopic grade benchmark.....	16
3.1.3 Transient macroscopic grade benchmark.....	17
3.2 Critical power benchmark.....	18
3.2.1 Steady-state benchmark.....	18
3.2.2 Transient benchmark.....	19
4. Formation of benchmark team.....	20
References.....	22
Interest in Participation (Form).....	23

**OECD/NRC INTERNATIONAL BENCHMARK BASED ON NUPEC
BWR FULL-SIZE FINE-MESH BUNDLE TESTS (BFBT)**

Summary

During the 4th OECD/NRC BWR TT Benchmark Workshop on 6 October 2002 in Seoul, Korea the need to refine models for best-estimate calculations based on good-quality experimental data was discussed. The needs arising in this respect should not be limited to currently available macroscopic approaches but should be extended to next-generation approaches that focus on more microscopic processes. It is suggested that this international benchmark be based on data made available from the NUPEC database. This fine-mesh high-quality data would encourage advancement in the insufficiently developed field of the two-phase flow theory. Considering that the present theoretical approach is relatively immature, the benchmark specification should be designed so that it will systematically assess and compare the participants' numerical models on the prediction of detailed void distributions and critical powers. Furthermore, the following points need to be kept in mind while the benchmark specification is being established:

- As concerns the numerical model of void distributions, no sound theoretical approach that could be applicable to a wide range of geometrical and operating conditions has been developed.
- In the past decade, experimental and computational technologies have been tremendously improved through the study of the two-phase flow structure. Over the next decade, it can be expected that mechanistic approaches will be more widely applied to the complicated two-phase fluid phenomena inside fuel bundles.

The development of truly mechanistic models for critical power prediction is currently underway. These innovative models should include elementary processes such as void distributions, droplet deposit, liquid film entrainment, etc.

Therefore, a benchmark problem that includes both macroscopic and microscopic measurement data was proposed. In this context, the sub-channel grade void fraction data are regarded as the macroscopic data, and the digitised computer graphic images are the microscopic data.

The proposed benchmark consists of two parts (phases). Each part consist of different exercises:

- **Phase 1 – Void Distribution Benchmark**
 - Exercise 1 – Steady-state sub-channel grade benchmark
 - Exercise 2 – Steady-state microscopic grade benchmark
 - Exercise 3 – Transient macroscopic grade benchmark
- **Phase 2 – Critical Power Benchmark**
 - Exercise 1 – Steady-state benchmark
 - Exercise 2 – Transient benchmark

It is expected that the benchmark activities will be performed as an international project officially approved by METI, NRC and endorsed by the OECD/NEA. The benchmark team will be organised based on the collaboration between Japan and the USA as shown in Figure A. It shall be recognised that METI had sponsored the NUPEC BWR bundle test project. Propriety of all information concerning the NUPEC BWR bundle test belongs to METI. OECD/NEA/NSC will be the international organiser of the benchmark project. The US team, headed by Professor Hochreiter and Professor Ivanov from Pennsylvania State University (PSU), will co-ordinate the benchmark project. They will prepare the benchmark specification, organise the workshops and answer the questions issued by participants. They will compare participants' results and issue the preliminary comparison reports and produce the final NEA/OECD and NUREG reports. The activity of the US team will be sponsored by the US NRC. The time frame of the NUPEC BWR full bundle test benchmark is shown in Table A.

Figure A. Formation of international benchmark team on NUPEC rod bundle test

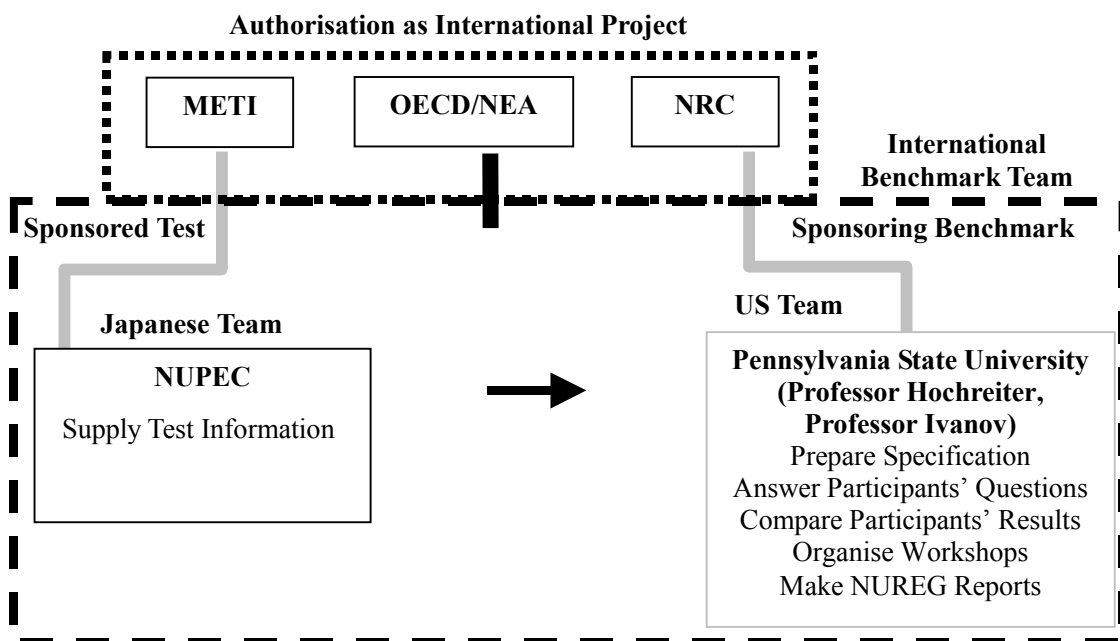

Table A. Time frame of NUPEC BWR full bundle test benchmark

(Year)	1	2	3
Specification			
<i>Phase 1</i>			
Exercise 1			
Exercise 2			
Exercise 3			
<i>Phase 2</i>			
Exercise 1			
Exercise 2			
<i>Documentation</i>			

1. Introduction

In the past decade, a large amount of effort has been made toward the direct simulation of the boiling transition (BT) for BWR fuel bundles. The most advanced sub-channel codes such as NASCA, FIDAS and COBRA-TF explicitly take into account droplet along with liquid and vapour. They predict the dryout process as disappearance of the liquid film on the fuel rod surface without employing any semi-empirical correlations. Through a series of benchmarks, it was verified that these codes are reliable in predicting the critical power of the conventional BWR fuel types. However, these sub-channel codes are not yet utilised in new fuel design. Adequacy of fuel lattice geometries, spacer configurations, etc., is still confirmed mainly by costly experiments using partial- and full-scale mock-ups. The main reason for this inconvenience is a shortage of high resolution and full-scale experimental databases under actual operating conditions.

The detailed void distribution inside the fuel bundle has been regarded as one of influential factors in the boiling transition in BWRs. When we discuss the sub-channel wise void distribution, it is clear that the cross flow across the sub-channel gap dominates void distributions. Most of the well-known sub-channel codes still employ the classical Lahey's Void Drift Model or its modified models. Although there have been substantial efforts to establish the sound theoretical background of detailed void distributions, the numerical models that are verified in a wide range of geometrical and thermal-hydraulic conditions are not yet available. In this sense, this subject still remains the major unsolved problem in the two-phase flow of BWR fuel bundles.

The main reason for this lack of resolution is the paucity of reliable full bundle databases under operating conditions. Up to now, only partial bundle (3×3 or 4×4) test data under relatively low pressure (≈ 1 MPa) conditions has been made available. The void distribution measurement for the full-size concentric 36-rod bundle of BHRW was performed by Nylund, *et al.* However, this test did not represent BWR core conditions. From 1987 to 1995, NUPEC (Nuclear Power Engineering Corporation) performed a series of void measurement tests using full-size mock-up tests for both BWRs and PWRs. Based on state-of-the-art computer tomograph (CT) technology, the void distribution was visualised at the mesh size smaller than the sub-channel under actual plant conditions. NUPEC also performed steady-state and transient critical power test series based on the equivalent full-size mock-ups. Considering the reliability

not only of the measured data, but also other relevant parameters such as the system pressure, inlet sub-cooling and rod surface temperature, these test series supply the first substantial database for the development of truly mechanistic and consistent models for void distribution and boiling transition.

There is no doubt that the international benchmark based on the NUPEC database will encourage advancement in this uncultivated field of two-phase flow theory. Considering the immaturity of the theoretical approach, the benchmark specification should be designed so that it will systematically assess and compare the participants' numerical models on the prediction of detailed void distributions and critical powers. Furthermore, the following points must be borne in mind while the benchmark specification is being established:

- As concerns the numerical model of void distributions, no sound theoretical approach that can be applied to a wide range of geometrical and operating conditions has been developed.
- In the past decade, experimental and computational technologies have tremendously improved though the study of the two-phase flow structure. Over the next decade, it can be expected that mechanistic approaches will be more widely applied to the complicated two-phase fluid phenomena inside fuel bundles.
- The development of truly mechanistic models for critical power prediction is currently underway. These models must include elementary processes such as void distributions, droplet deposit, liquid film entrainment, etc. The benchmark specification will require participants to explain correlations between the critical power and these dominant processes.

It should be recognised that the purpose of this benchmark is not only the comparison of currently available macroscopic approaches but above-all the encouragement to developing novel next-generation approaches that focus on more microscopic processes. Thus, the benchmark problem includes both macroscopic and microscopic measurement data. In this context, the sub-channel grade void fraction data are regarded as the macroscopic data, and the digitised computer graphic images are the microscopic data.

With this document as a starting point, it is hoped that a small working group will be organised between NUPEC and PSU and that it will work together with the OECD/NEA and the NRC to prepare this ambitious specification.

2. Summary of NUPEC BWR full-size bundle test

The NUPEC BWR full-size bundle test includes two major parts: the void distribution measurement and the critical power measurement.

2.1 BWR rod bundle void distribution measurement

2.1.1 Test facility

Figure 1 shows a diagram of the test loop. The main structural components were made of SUS304. The working coolant was the demineralised water. The maximum capacity of the facility was:

- Pressure = 10.3 MPa.
- Temperature = 315 Celsius.
- Power = 12 MW.
- Flow = 33 kg/sec.

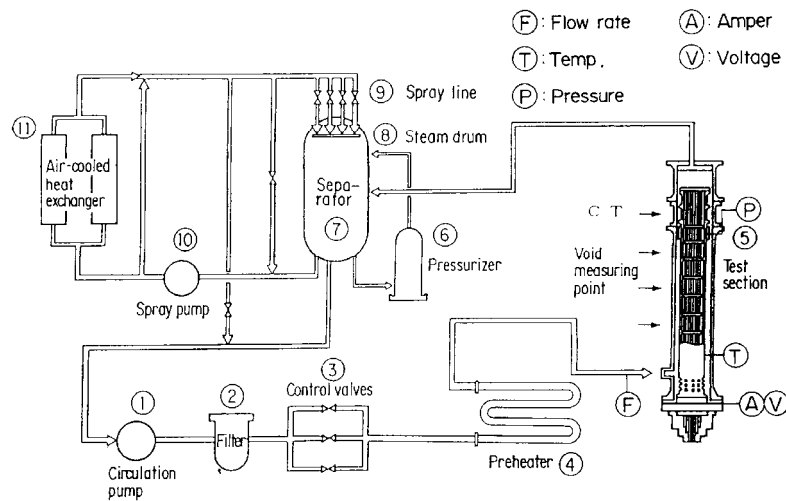
Figure 1. System diagram of test facility for NUPEC rod bundle test series

The flow rate was controlled by the three valves (3). The inlet sub-cooling was controlled by the direct-heating pre-heater (4). In test section (5), the sub-cooled flow became the two-phase flow and was driven to the separator in order to separate the steam from the steam-water mixture. The system pressure was controlled by the spray line with four different valve sizes (9). The pressurizer (6) controls the system pressure when the power is low. Based on this diagram, the test loop was operated covering the full range of BWR steady-state operating condition.

A detailed structure of the test section (5) is illustrated in Figure 2. The test mock-up simulated the full-size 8×8 BWR fuel bundles. The two bundle types, the previous type and the high burn-up type, were used. The mock-up consists of electrically heated rods with Inconel cladding, boron nitride insulator and Nichrome heater. Table 1 summarises the five types (Type 0 to Type 4) of test assemblies with different combinations of cross geometries and power shapes.

Figure 2. Cross-sectional view of test section

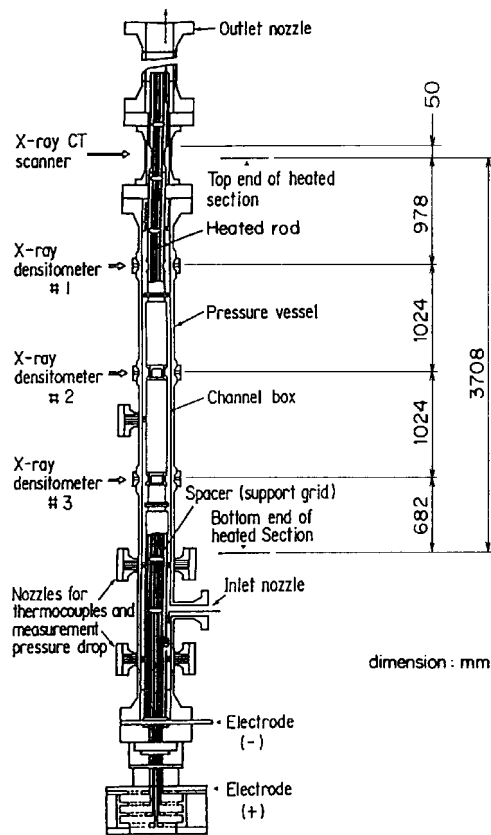
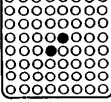
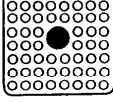
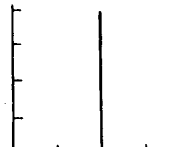
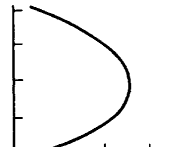
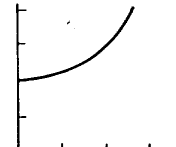

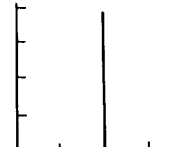

Table 1. Test assembly and radial power distribution for void distribution measurement

Test assembly No.	0	1	2	3	4
Fuel Type		Current use 8x8 			High burnup 8x8 
Planar power profile	Uniform	Simulated design profile	Simulated design profile	Simulated design profile	Simulated design profile
Axial power profile	Uniform	Cosine	Half-cosine	Inlet peak	Uniform
Heated length	Full	Full	Half	Full	Full
Axial power distribution Axial Power					

2.1.2 Void fraction measurement methods

Two kinds of void distribution measurement systems, the X-ray CT scanner and the X-ray densitometer (as shown in Figure 3) were employed in this test.

Figure 3. Void fraction measurement system

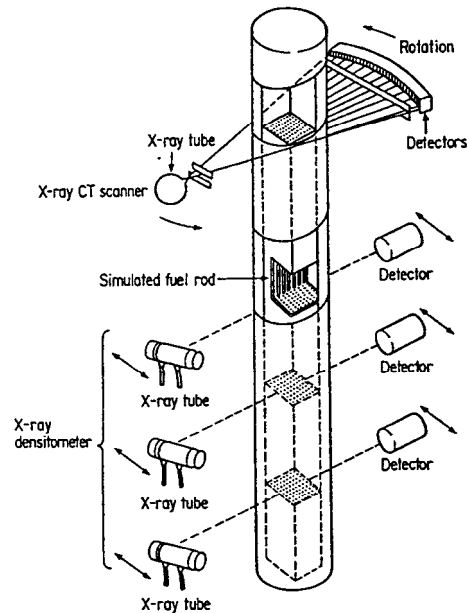

Detailed void distributions were measured using the X-ray CT scanner at the bundle exit under steady-state conditions. The facility shown in Figure 4 consists of an X-ray tube and 512 detectors. In order to avoid the effect of the two-phase flow fluctuations, the collection of projection data was repeated and the results were time-averaged. The digitised projection data was reconstructed into the image data based on the filtered-back projection method that is frequently applied in the medical field. The attained resolution was as small as $0.3 \text{ mm} \times 0.3 \text{ mm}$.

Figure 4. Conception X-ray CT scanning method

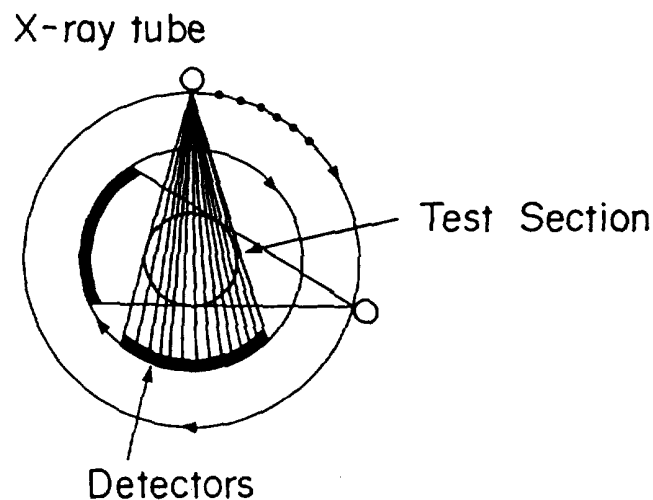

The cross-sectional average transient void distributions were measured by the X-ray densitometer. The measurement was performed at several middle elevations where the X-ray transmission sections made of beryllium (Be) rods of the same outer diameter as the heat rods were installed.

The pressure and its difference were measured by the diaphragm transducers and the inlet flow rate was measured by the turbine flow meter. The inlet sub-cooling was measured by the double thermistors. In the heater rods, the surface temperature was monitored at positions just upstream of the spacers by the 0.5 mm diameter chromel-alumel thermocouples. Table 2 summarises the estimated accuracies of the major process parameters in this test series.

Table 2. Estimated accuracy of main process parameters for void distribution measurement

Quantity	Accuracy
Pressure	1%
Flow	1%
Power	1.5%
Inlet fluid temperature	1.5 Celsius
X-ray CT scanner	
Local void fraction	8%
Sub-channel void fraction	3%
Cross-sectional void fraction	2%
Spatial resolution	0.3 mm × 0.3 mm
Scanning time	15 seconds
X-ray densitometer	
Sampling time	Max. 60 seconds

2.1.3 Test conditions

2.1.3.1 Steady-state tests

This test series was performed under conditions that envelope bundle geometrical, power shape and two-phase flow parameters of the actual plant steady-state operation. Both the X-ray CT scanner and the X-ray densitometer technique were applied. The resultant range of test conditions was as follows:

- Pressure: 1-8.6 MPa.
- Flow rate: 284-1 988 kg/m²-s.
- Power = Exit quality: 1-25%.

In all, 476 measurement points were included in this test series.

2.1.3.2 Transient tests

This test was intended to help understand the cross-sectional averaged transient void behaviours against pressure, flow and power changes. The X-ray densitometer was applied in this test. Among the major operational transients, the following four events were run, each one with a specific influence on the void fluctuation:

- Turbine trip without bypass.
- One pump trip.
- Re-circulation pump stick.
- Malfunction of pressure control system (pressure increase).

The above four events include the combined effects of pressure, flow and power (= quality). In order to obtain the separated sensitivity on these basic process parameters, additional tests were performed in which one of these three parameters was changed.

2.2 BWR critical power measurement

2.2.1 Test facility

The same test loop as that used in the void distribution measurement (Figure 1) was employed for this test. The test loop was operated under normal BWR operational conditions and typical transient conditions corresponding to the one pump trip event and the turbine trip event.

The full-scale test mock-ups simulating the 8×8 high burn-up fuel were installed in the test section. Three combinations of radial and axial power shapes, C2A, C2B and C3, were included as illustrated in Table 3. The applied radial and axial power shapes were shown in Figures 5 and 6. Types C2A and C3 simulated the high radial peaking condition at the beginning of cycle while Type C2B simulated the high bundle power condition at the end of cycle. The rod surface temperature and the pressure loss were monitored at several locations as depicted in Figures 7 and 8.

Table 3. Test assemblies and radial power distributions for critical power measurement

Test item	Flow-induced vibration test		Critical power test		
	V1	V2	C2A	C2B	C3
Test assembly	V1	V2	C2A	C2B	C3
Fuel type	Current 8×8	High burn-up 8×8	High burn-up 8×8		
Axial power shape	Uniform	Uniform	Cosine	Cosine	Inlet peak
Radial power shape	Uniform	Uniform	A	B	A

A – Simulation pattern for beginning of operation.

B – Simulation pattern for middle of operation.

2.2.2 Critical power measurement methods

The critical power was measured by slowly increasing the rod power while monitoring the thermocouple signals. The critical power was defined when the peak rod surface temperature became 14 Celsius higher than the steady-state level before dryout occurred. The dryout was observed in the peak power rod located at the peripheral row neighbouring the channel box. The boiling transition was always observed at the upstream of spacers. The estimated accuracies of the major process parameters were equivalent to those in the void measurement test as listed in Table 2.

Figure 5. Two radial power distribution patterns for critical power measurement

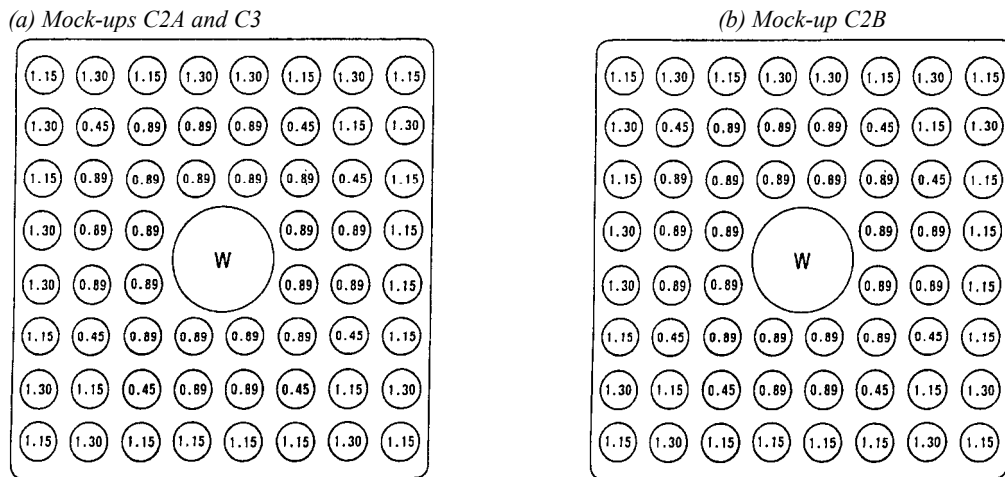

Figure 6. Two axial power distribution patterns for critical power measurement

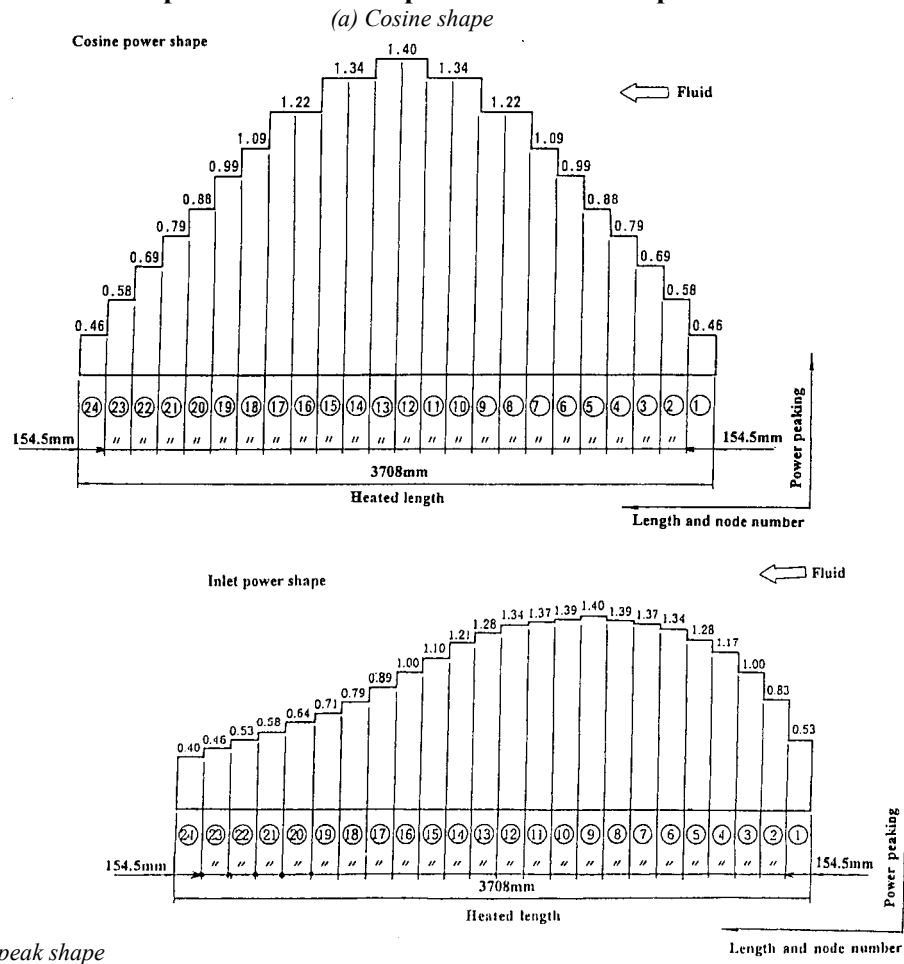

Figure 7. Location of thermocouples for critical power measurement

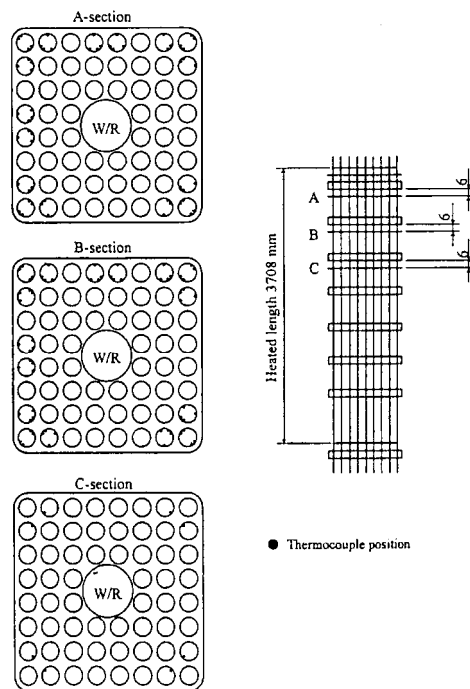
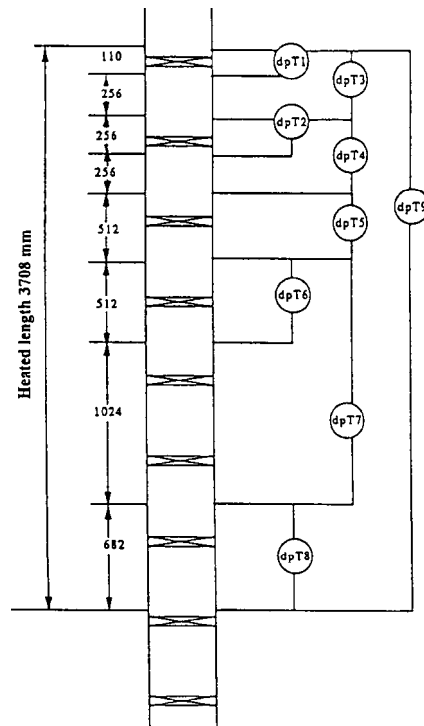

Figure 8. Location of pressure taps for critical power measurement



2.2.3 Test conditions

2.2.3.1 Steady-state test series

The steady-state test series consisted of two parts. One was the pressure drop measurement and another was the critical power test. The pressure drop was measured in both single-phase flow and two-phase flow state that cover the normal operational condition.

The range of each test conditions was as follows:

- Single-phase pressure drop measurement:
 - Pressure: 0.1, 1.0, 7.2 MPa.
 - Flow rate: 267-2 055 kg/m²·s.
- Two-phase pressure drop measurement:
 - Pressure: 7.2, 8.6 MPa.
 - Flow rate: 267-2 055 kg/m²·s.
 - Inlet sub-cooling: 50 kJ/kg.
 - Exit quality: 0.07-0.25.
- Critical power test:
 - Pressure: 5.5-8.6 MPa.
 - Flow rate: 267-1 740 kg/m²·s.
 - Inlet sub-cooling: 25-126 kJ/kg.

In total, 151 measurement points were run during the critical power test.

2.2.3.2 Transient test series

The two typical operational transients:

- 1) Power transient: Turbine trip event.
- 2) Flow transient: One recirculation pump trip event.

- *License base transient test*

The boundary conditions corresponding to the above-mentioned two transient events were shown in Figures 9(a) and 9(b). The objective of this test series was confirmation that the boiling transient never occurs during these transients.

- *Extreme scenario transition test*

The initial power levels were increased in the previous transient events in order to observe the boiling transition. The rod surface temperature was monitored.

- *Post-boiling transition test*

The rod surface temperature was measured under the quasi-steady-state condition beyond the boiling transition. The main purpose of this test series was quantification of the post-dryout heat transfer coefficient. Additional test conditions are as follows:

- Pressure: 7.2 MPa.
- Flow rate: 267-1 470 kg/m²·s.
- Inlet sub-cooling: 50 kJ/kg.

Figure 9. Typical boundary conditions for critical power measurement

(a) Turbine trip (b) One pump trip

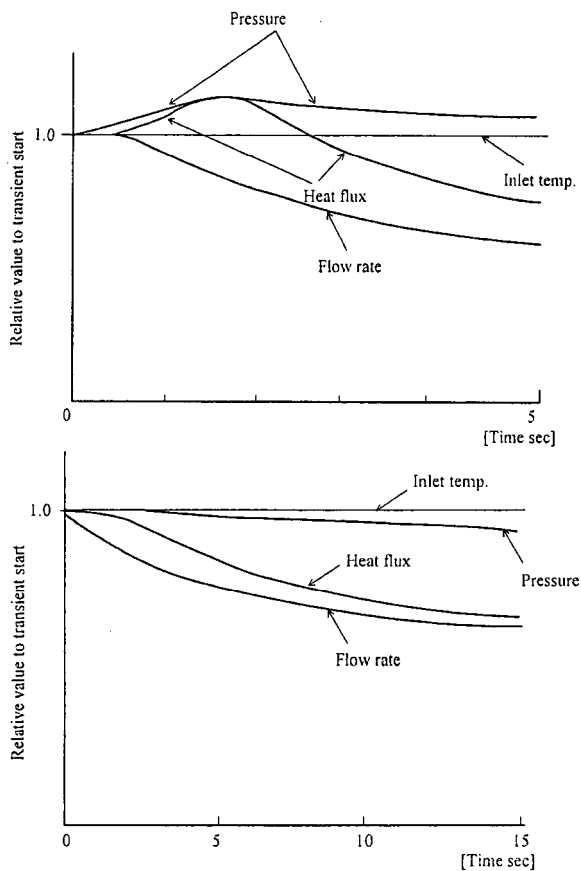

3. Proposal of benchmark problems

The sub-channel approach is categorised as the macroscopic grade that can resolve as small as a sub-channel size mesh. Time and space averaged formulations cause the loss of the heterogeneous and instantaneous information in the two-phase flow structure. As a consequence, many macroscopic correlations are still indispensable for reproducing the experimental results. In recent years, there have been newer two-phase flow numerical approaches that can be categorised into meso, micro or molecular dynamics grade. Taking into account the immaturity of numerical modelling for detailed void distribution, it is desirable to plan the benchmark specification to accept as many potential numerical approaches as possible.

The benchmark exercises consist of two parts, the void distribution and the critical power. The participants can choose either of the following two parts. Ideally, it is hoped that a sufficient number of participants will attempt both exercises so as to explain the two measurement results based on their consistent numerical approaches.

In addition to the measured experimental data and the relevant boundary conditions, the detailed geometrical data of mock-up assemblies, spacers and the test loop will be included as far as possible in the specification in order to allow a wide range of numerical modelling. At the moment, the following benchmark problems can be proposed as attractive challenges for many participants.

3.1 Void distribution benchmark

The steady-state void distribution results were normally supplied as the time-space averaged value in a sub-channel size. However, the raw image data has a resolution as small as 0.3 mm × 0.3 mm and the liquid film on the rod surfaces can be roughly recognised from these images. If it is possible to recover these image data and to transform them into the uncompressed ASCII image format, it is desirable to include them for the optional benchmark subjects of the microscopic two-phase numerical approaches.

3.1.1 Steady-state sub-channel grade benchmark

1) Numerical approaches:	Sub-channel, meso and microscopic approaches
2) Supplied data:	Time and space averaged void distribution matrix in sub-channel mesh size
	Corresponding boundary conditions (pressure, flow, inlet sub-cooling, power shape) [Table 4]

3.1.2 Steady-state microscopic grade benchmark

1) Numerical approaches:	Meso and microscopic approaches, molecular dynamics
2) Supplied data:	Time and space averaged void distribution matrix in 0.3 mm × 0.3 mm mesh size
	Corresponding boundary conditions (pressure, flow, inlet sub-cooling, power shape) [Table 5]

Table 4. Data format of steady-state sub-channel grade void distribution benchmark

	1	2	3	4	5	6	7	8
Test assembly type	X.X	X.X	X.X	X.X	X.X	X.X	X.X	X.X
System pressure= X.X MPa	X.X	X.X	X.X	X.X	X.X	X.X	X.X	X.X
Flow rate = X.X kg/m ² -s	X.X	X.X	X.X	X.X	X.X	X.X	X.X	X.X
Inlet subcooling= X.X Celsius	X.X	X.X	X.X	X.X	X.X	X.X	X.X	X.X
Power shape = -	X.X	X.X	X.X	X.X	X.X	X.X	X.X	X.X
	X.X	X.X	X.X	X.X	X.X	X.X	X.X	X.X
	X.X	X.X	X.X	X.X	X.X	X.X	X.X	X.X
	X.X	X.X	X.X	X.X	X.X	X.X	X.X	X.X

Table 5. Data format of steady-state microscopic grade void distribution benchmark

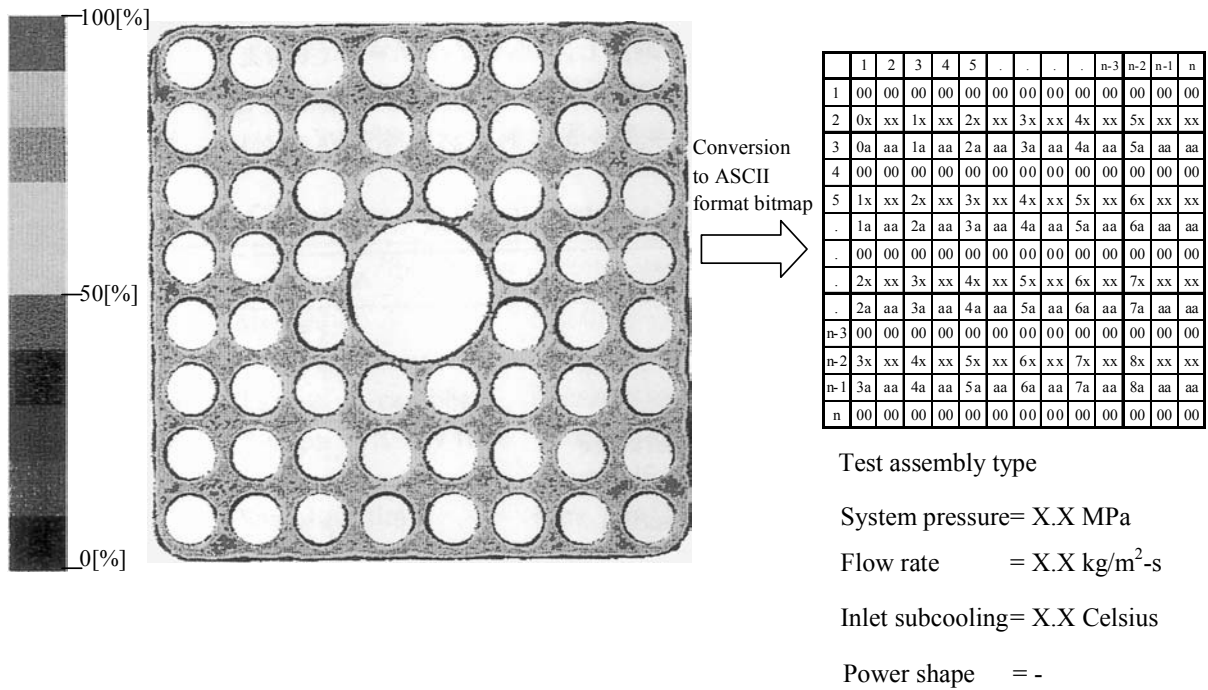

3.1.3 Transient macroscopic grade benchmark

1) Numerical approaches:	Sub-channel
2) Supplied data:	Space averaged instantaneous axial void profiles during transients
	Corresponding boundary conditions (pressure, flow, inlet sub-cooling, power shape) [Table 6]

Table 6. Data format of transient macroscopic grade void distribution benchmark

Cross-sectional averaged void fraction	Elevation-1	Elevation-2	Elevation-N-1	Elevation-N
Time1					
Time2					
Time3					
....					
TimeM-3					
TimeM-2					
TimeM-1					
TimeM					

Histories of boundary conditions	Pressure	Heat flux	Flow rate	Inlet temperature
Time1				
Time2				
Time3				
....				
TimeM-3				
TimeM-2				
TimeM-1				
TimeM				

Test assembly type
Power shape = -

3.2 Critical power benchmark

Basically, two approaches can be applied in the critical power benchmark. They are:

- One-dimensional approach with BT correlation. . Participants may develop their own BT correlations based on test points. However, this will not be part of the objectives of this benchmark.
- Sub-channel mechanistic approach.

The required outputs by participants will be determined according to these approaches. For all approaches, the following will be required as the minimum outputs for the steady-state benchmark:

- Single-phase pressure drop.
- Two-phase pressure drop.
- Critical power.
- Axial location of boiling transition.
- Quality/void profile at critical power.
- Rod surface temperature profile at critical power.

In case of the three-field sub-channel codes, the additional outputs will be:

- Detailed radial location of boiling transition.
- Liquid film thickness profile at critical power.
- Droplet volume fraction profile at critical power.

3.2.1 Steady-state benchmark

1) Numerical approaches:	One-dimensional approach with BT correlation and sub-channel mechanistic approach
2) Supplied data:	Single-phase pressure drop Two-phase pressure drop Critical power Location of boiling transition Corresponding boundary conditions (pressure, flow, inlet sub-cooling, power shape) [Table 7]

Table 7. Data format of steady-state critical power benchmark

No. of test points	Pressure	Flow rate	Inlet temperature	Pressure drop	Critical power	Location
1	Given	Given	Given	Measured	Measured	Measured
2	Given	Given	Given	Measured	Measured	Measured
3	Given	Given	Given	Measured	Measured	Measured
....						
151	Given	Given	Given	Measured	Measured	Measured

Test assembly type
Power shape = -

3.2.2 Transient benchmark

1) Numerical approaches:	One-dimensional approach with BT correlation, sub-channel mechanistic approach
2) Supplied data:	Timing of boiling transition Timing of rewetting Maximum rod surface temperature Location of boiling transition Histories of thermocouples Corresponding boundary conditions (pressure, flow, inlet sub-cooling, power shape) [Table 8]

Table 8. Data format of transient critical power benchmark

No. of test points	Transient type	Assembly type	Timing of BT	Maximum rod temp.	Timing of rewet
1	Given	-	Measured	Measured	Measured
2	Given	-	Measured	Measured	Measured
3	Given	-	Measured	Measured	Measured
....					

History of thermocouples	TC-1	TC -2	TC -N-1	TC -N
Time1					
Time2					
Time3					
....					
TimeM-3					
TimeM-2					
TimeM-1					
TimeM					

Histories of boundary conditions	Pressure	Heat flux	Flow rate	Inlet temperature
Time1				
Time2				
Time3				
....				
TimeN-3				
TimeN-2				
TimeN-1				
TimeN				

4. Formation of benchmark team

It is expected that the benchmark will be realised as the international project officially approved by METI, NRC and endorsed by the OECD/NEA. The benchmark team will be organised based on the collaboration between Japan and USA as shown in Figure 10. It shall be recognised that METI had sponsored the NUPEC BWR bundle test project. Proprietary of all information concerning the NUPEC BWR bundle test belongs to METI.

OECD/NEA/NSC will be the international organiser of the benchmark project. The processes and the proposal for NUPEC test information disclosure will first be issued by the OECD/NEA.

NUPEC will perform necessary disclosure processes of test data such as:

- Submission of the information disclosure request to METI.
- Providing information for the specification of test bundles based on the NUPEC reports submitted to METI.
- Reprocessing of the test data (i.e. void distribution image data) into easily available formats.

The OECD/NEA will arrange for the translation of the NUPEC test reports from Japanese to English.

The US team headed by Professor Hochreiter and Professor Ivanov will co-ordinate the benchmark project. They will propose to commence the benchmark project at the NEA workshop, prepare the benchmark specification, organise the workshops and answer the questions issued by participants. They will compare participants' results and issue the preliminary comparison reports and make the final NUREG report. The activity of the US team will be sponsored by the US-NRC.

Figure 10. Formation of international benchmark team on NUPEC rod bundle test

1.

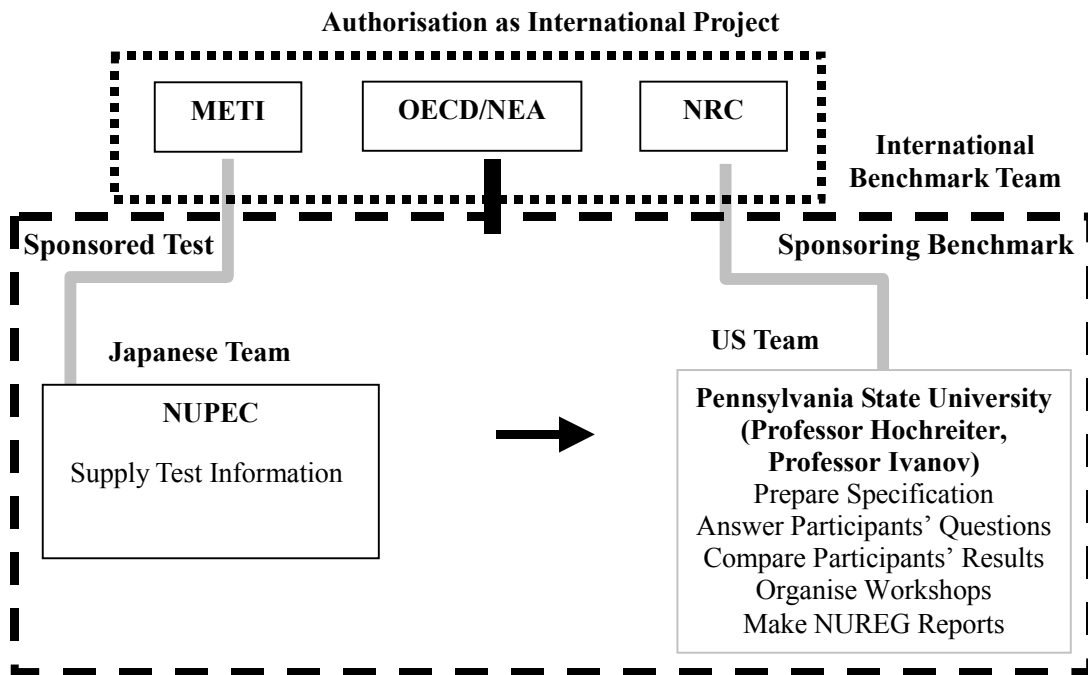

REFERENCES

- [1] “Void Measurement of BWR Fuel Assembly”, *J. of Atomic Energy Society of Japan*, Vol. 37, No. 8, p. 710 (1995) (in Japanese)
- [2] “Void Fraction Distribution in BWR Fuel Assembly and Evaluation of Sub-channel Code”, *J. of Nucl. Sci. and Tech.*, Vol. 32, No. 7, p. 629 (1995).
- [3] “Proving Test on Thermal-hydraulic Performance of High Burn-up 8 × 8 Fuel Assembly”, *J. of Atomic Energy Society of Japan*, Vol. 40, No. 10, p. 784 (1998) (in Japanese).

**OECD/NRC Benchmark Based on NUPEC BWR
Full-size Fine-mesh Bundle Tests (BFBT)**

Interest in Participation

Please send to Kostadin Ivanov, PSU (kni1@psu.edu) and Enrico Sartori, OECD/NEA (sartori@nea.fr)
fax: +1 (814) 865 8499 fax: +33 1 4524 1110

I am interested in participating in thie BFBT benchmark study.

Name:

Address:

e-mail:

telephone:

fax:

I intend to use the following code:

Comments and Expectations from this benchmark: