

SUMMARY OF THE RESULTS OF THE COMPARISON OF
CALCULATIONS AND MEASUREMENTS FOR THE TN12 FLASK
CARRIED OUT UNDER THE NEACRP INTERCOMPARISON OF
SHIELDING CODES.

BY

Mrs. H.F. LOCKE

Safety Engineering Systems Division
RPSCD Department
AEA Technology
Winfrith

March 1992

| | NAME | SIGNATURE | POSITION | DATE |
|-------------|-------------|-------------|------------------|----------|
| Lead Author | H. F. Locke | H F. Locke | Calculator | 25/11/92 |
| Checked | A. F. Avery | A. F. Avery | Section leader | 9/12/92 |
| Approved | G. J. Lloyd | G J Lloyd | Division Manager | 17-12-92 |

94350002

SUMMARY OF THE RESULTS OF THE COMPARISON OF
CALCULATIONS AND MEASUREMENTS FOR THE TN12 FLASK
CARRIED OUT UNDER THE NEACRP INTERCOMPARISON OF
SHIELDING CODES.

BY

Mrs. H.F. LOCKE

Safety Engineering Systems Division
RPSCD Department
AEA Technology
Winfrith

March 1992

94350003

1 INTRODUCTION

The Reactor Physics Committee of the Nuclear Energy Agency set up a project in 1985 to exchange information and experience on shielding calculations for the transportation of spent reactor fuel. This took the form of an intercomparison of codes for carrying out such calculations, and it followed the pattern of similar exercises which had been set up for criticality and heat transfer assessments of fuel transport.

The first stage of the exercise contained six theoretical benchmark problems (1) for which participants were invited to submit results together with the methods of the calculation employed. The problems could be divided into two groups; the first four had sources which were defined in terms of their strength and spectra while problems 5 and 6 involved the calculation of the sources from data provided on the fuel assemblies and their radiation histories. A comparison of solutions to these problems suffered from the drawback that there were no definitive answers against which results could be checked; therefore the second stage of the exercise involved an experimental benchmark against which the accuracy of predictions could be tested.

The benchmark experiment chosen was the set of measurements for the TN12 flask, submitted by the CEA and Transnucleaire of France (2). These were chosen as being the most suitable for comparison with calculated values because they were for a dry container, having steel as its principal material, so that it was similar to the flasks already studied in the theoretical problems. The type TN12 container is used for large scale transportation of irradiated fuel. It carries 12 PWR fuel elements within a steel-walled flask fitted with external copper fins. A polyester resin is located between the fins over part of their length in order to provide neutron shielding. Gamma-ray dose-rates had been measured for one set of fuel elements with known burn-up distributions and power histories. Neutron measurements had been made for a second set of elements.

2.0 THE TN12 CONTAINER

2.1 Description

The TN12 container (figure 1) consists of a cylindrical cavity, housing the fuel assembly storage basket (figure 2) surrounded by a carbon steel wall, approximately 30cm thick. The radial wall is thinner near the top and bottom. The outside of the container is covered, over approximately the length of the cavity, with copper fins. Neutron shielding made from resin is located between the fins on the outer surface of

the container wall for a thickness of 10.5cm. There are shock absorbers on either side of the finned area each consisting of a stainless steel shell packed with balsa wood (figure 3).

The storage basket (figure 2) is made from aluminium alloy sections reinforced by stainless steel grids. These sections also contain B_4C -Cu plates (neutron poison) and are separated by stainless steel cruciform inserts. The basket holds 12 fuel assemblies and their individual positions are shown in figure 4.

The fuel assemblies consist of a 17 x 17 lattice arrangement of 264 fuel rods, 24 guide tubes and 1 instrumentation tube, within a support framework. The fuel rods consist of UO_2 pellets which are contained in zircaloy tubes fitted with end plugs; the tubes also contain expansion volumes and springs to hold the pellets in place.

2.2 Model specification

All design features and dimensions were provided in the specification (2) and two further documents (3,4). The material information given assumed smearing of the following regions:-

- (a) the fin base and resin into one region of homogeneous material.
- (b) the fins and adjacent void into one region of copper of the same mass and therefore lower density

(A diagram of the fins was supplied, figure 5, for those participants who wished to model these areas in more detail.)

- (c) shielding areas containing more than one material and void eg. support skirts, basket support and basket.
- (d) regions within the fuel assemblies eg. fittings, plenum, active length.

The material compositions for the container are shown in table 1.

2.3 Fuel Assemblies

Each fuel assembly was divided into the following regions (figure 6) :-

- (1) Top nozzle including hold down springs.(A)
- (2) Region between the top nozzle and the top of the fuel rods. (Btop)
- (3) Void volume in the fuel rods including springs and upper grid. (C)

- (4) Active length of the fuel.(D)
- (5) Region between the bottom of the fuel rods and the bottom nozzle. (Bbot)
- (6) Bottom nozzle. (E)

Table 2 describes the characteristics of each fuel assembly and table 3 gives a list of components, with details of material composition in table 4.

3 SOURCE CALCULATIONS

3.1 Specification

3.1.1 Gamma-ray benchmark

Table 5 gives a description of the individual fuel assemblies used in the gamma-ray benchmark experiment, including details of irradiation history. This was made up of two cycles (figure 7), with some assemblies (1-7 in figure 4) being used for the first fuel cycle only; the remainder (8-12) were used in two cycles. The cooling time for the two groups was 816 days and 383 days respectively. Details of the axial burn-up distribution for each fuel assembly are shown in table 6.

3.1.2 Neutron benchmark

For the neutron benchmark each assembly contained 462kg of uranium at 3.13% enrichment in U235 initially. The power history was made up of three cycles as shown in table 7 while table 8 gives the total burn-up for each assembly at the end of each cycle. Details of the axial distribution of burn-up are shown in table 9. A value of k-eff of 0.15 was quoted for the loaded flask giving a multiplication factor of 1.18. Participants could, however, calculate multiplication themselves.

3.2 Methods of Calculation

Three codes were used by the participants to calculate source strengths. These were FISPIN (UK), APOLLO (France) and ORIGEN (USA, Italy, Netherlands, Belgium, and Germany) although not always the same version of the latter. Descriptions of these codes were given in the report comparing solutions to problems 5 and 6 (5).

3.3 Results

3.3.1 Gamma-ray benchmark

The source strength varied along the length of each fuel assembly because of the axial distribution of burn-up. Each participant used a different method to allow for this effect. This included performing source calculations at several burn-ups covering the range for each assembly and then either fitting a polynomial through the results (6) or dividing the assembly into bands of uniform burn-up (7). Renard (8) performed the calculations for an average assembly and then multiplied by the relative local burn-up in each region.

To enable a comparison of source strengths participants were asked to provide the gamma-ray source spectrum for assemblies 5 and 12 (tables 10 to 13), corresponding to the two irradiation histories, for the burn-up at mid-height and the top interval. These values are 19461 and 2966MWd/tonne for assembly 5 and 27723 and 10959MWd/tonne for assembly 12. Results are presented in terms of energy emitted.

For assembly 5, at mid-height the total energy emitted varies from $4.27E+15$ MeV/s/tonne to $6.42E+15$ MeV/s/tonne. The Dutch (9), UK/BNFL (10) and French values are at the lower end of the range but their results do not cover the full spectrum. In the important energy group for determining dose-rates outside steel flasks, 2.0 to 2.5 MeV, the results are in agreement, being approximately $1.0E+14$ MeV/s/tonne. The largest contribution to the source comes from energies in the range 0.4 to 0.8 MeV. Inclusion of bremsstrahlung in some libraries, which yields gamma-rays with energies predominantly below 0.4MeV, may explain the differences between the total energy emitted (5). Similar results are obtained for assembly 12 at mid-height.

For the top interval of assembly 5 there is more variation in the total source strength with a factor of 2.5 difference between the highest (Belgium) and the lowest (UK/BNFL). However there is again better agreement for the energy group 2.0 to 2.5MeV. A similar spread of results is obtained for the top interval of assembly 12 in the group 2.0 to 2.5MeV; but there is less variation in the total source. The dependence of the agreement on rating and burn-up suggests that the consistency of fission product yields between the libraries may differ for the various actinides or the effect of the burn-up of fission products is treated more accurately in some codes than in others.

3.3.2 Neutron benchmark

The irradiation history for the 12 assemblies was identical although burn-ups at the end of each cycle showed some variation (see table 8). Some participants divided

the assemblies into 2 or 3 groups with similar total burn-up; others looked at a mean assembly. To enable a comparison of source strengths participants were asked to provide the total neutron source from both spontaneous fission and α -n reactions for assemblies 5 and 12 (table 14), corresponding to the two irradiation histories, for the burn-up at mid-height and the top interval. These values are 38780 and 14862MWd/tonne for assembly 5 and 38893 and 14930MWd/tonne for assembly 12.

The predicted source strengths for spontaneous fission at the midheight of both assemblies mostly lie between $6.17\text{E}+8$ to $7.56\text{E}+8$ n/s/tonne. The UK/BNFL result (10) is lower; however their results are not true midheight values but correspond to the height of active fuel region from 19.3 to 340.1cm, with a mean burn-up of less than 38780MWd/tonne. For the top interval the results show a wider variation with eleven values lying in the range $8.54\text{E}+6$ to $1.30\text{E}+7$ n/s/tonne, and one value of $2.81\text{E}+7$ (US(11)), showing a greater difference.

The source strengths for α -n reactions at the midheight of both assemblies lie between $1.53\text{E}+7$ to $1.68\text{E}+7$ n/s/tonne, with one higher value of $3.42\text{E}+7$ (Germany(12)). The UK/BNFL result is not a true mid-height value. For the top interval the range is $1.30\text{E}+6$ to $3.70\text{E}+6$ n/s/tonne, with the German result being the higher value. The top interval again shows a wider variation. The German results for α -n reactions are consistent with those for problems 5 and 6, where the source strengths were also a factor of 2 higher than those from the other participants.

The concentrations of actinides which contribute to the source strength of assembly 12 are shown in table 15. There is reasonable agreement between the participants eg. a range of $1.03\text{E}+23$ to $1.59\text{E}+23$ nuclei/tonne for Cm244 ; and $6.08\text{E}+24$ to $7.10\text{E}+24$ nuclei/tonne for Pu240 at the midheight. The corresponding values for the top of the assembly are $1.06\text{E}+21$ to $4.65\text{E}+21$ nuclei/tonne and $2.50\text{E}+24$ to $3.18\text{E}+24$ nuclei/tonne respectively. However there is a wider variation in results for Cm246 and Cf252 which do not contribute much to the source strength. The total neutron source strengths vary rapidly with burn-up so that the larger spread in the results at the top of the fuel is probably due to the way in which the axial profile has been represented, leading to different effective burn-ups for the top region.

The neutron spectra used in the dose-rate calculations varied between participants and these are shown in tables 16 and 17 .

4.0 COBALT ACTIVATION IN THE END FITTINGS

A second source of gamma-rays comes from the activation of the end fittings within the reactor, in particular the Co59 present in the fittings and mixing grids of each fuel assembly. Thermal neutron fluxes at the top and bottom of each assembly

were calculated by the CEA and are shown in figures 8 and 9. The composition of the fittings is shown in table 3. The UK used values of thermal flux produced by FISPIN for the mixing grids. ORIGEN, however includes activation within the active length of the fuel in calculating source strengths so that no further calculation was necessary for the mixing grids.

Different methods were employed to calculate the decay rates, shown in table 18, for the top and bottom nozzles and the mixing grid at mid-height. These were either hand calculations or using codes such as FACT and ORIGEN.

Table 18 shows a wide variation in results which may be due to:-

- (i) activation cross-section used,
- (ii) differences in concentration of Co59 in the separate regions because of difficulties in interpreting table 2,
- and (iii) thermal flux used at mid-height.

5.0 DOSE-RATE CALCULATIONS

5.1 Methods

Dose-rates were calculated using the following codes which were described in reference 13, except for MARMER (14) which is a point-kernel gamma shielding code which is based on the MERCURE-IV shielding code (15) and the MARS geometry package (16).

| | |
|------------|-------------------------------------|
| MCBEND | UK AEA (7) and BNFL (10) |
| MCNP | Italy (6) and Belgium (8) |
| SAS4 | USA (11) |
| TRIPOLI | French neutron calculations (17) |
| MERCURE-IV | French gamma-ray calculations (18) |
| MARMER | Netherlands (14) |
| ANISN | Belgium (8) and Germany (12) |
| DORT | USA (11) |
| RANKERN | UK/BNFL gamma-ray calculations (10) |
| QAD-CG | Belgium gamma-ray calculations (8) |

Calculations of the dose-rate using the standard conversion factor of neutron flux to equivalent dose-rate (table 19) were found to produce large discrepancies

between calculated and experimental dose-rates. This was attributed to the response of the cylindrical He₃ detector (figures 10 and 11) encased in paraffin wax which was used in the measurements. This differed from that of an ideal dosimeter and a 1 dimensional adjoint calculation was carried out by CEA Saclay (19) for a spherical model of the counter in order to determine a more appropriate response function to be used in the benchmark problem (table 15) (20).

A 2 dimensional calculation was later carried out by UK/AEA (21) using MCBEND to produce an angular response function for the detector. UK/AEA repeated their benchmark calculations to provide angular fluxes outside the flask so that the new response function could be used to provide dose-rates.

5.2 Results

5.2.1 Gamma-ray benchmark

The results of the calculations are shown in tables 20 and 21 along with the experimental measurements. In general the agreement is good between the codes and with the experiment with the ratios of calculated to measured values (C/M) lying in the range 0.58 to 1.55. This level of agreement is satisfactory when the large attenuations involved are taken into account. UK/AEA results (7) allow for a correction factor of about 1.4 for the smeared modelling of the fins; but the other participants show agreement without this factor. UK/AEA produced a 3 dimensional model of a fin and compared their results with a smeared model to determine the correction factors. Parkes et al (11) had also considered the fin effect using a 2 dimensional model of the fin, smeared to be continuous azimuthally. In contrast their results showed that the effect was negligible. This disagreement on the importance of the discrete modelling of the fins has not been resolved.

The results corresponding to the top and bottom peaks show a wider variation which could be partly due to the differences in the cobalt source in the end fittings and the uncertainty in the interpretation of the specification of the thermal neutron flux in these regions during irradiation of the fuel.

5.2.2 Neutron benchmark

The results of the calculations are shown in table 22 along with the experimental measurements. UK (AEA and BNFL), Germany and Italy show good agreement with experiment on the surface at midheight, with the C/M ratio lying between 0.96 and 1.16, although this deteriorates with distance from the flask. This suggested that there

was an angular dependence of the dosimeter response which had not been considered in the 1 dimensional calculation of the response function. When the UK/AEA repeated their calculations with their angular response function (21) the trend for poorer agreement at distances away from the flask disappeared with C/Ms of 0.92, 0.90 and 0.99 for dose-points of 15.5cm, 1m and 1.81m respectively. This corresponds to factors of 0.90, 1.02 and 1.29 respectively at the three distances to correct for the angular response of the dosimeter.

The results at the peaks at the top and bottom of the flask are not so good. This may be partly due to the treatment of balsa used in the calculations. It is represented as water of density 0.25g/cm^3 in the original specification, although in the calculations of Locke (7) this was replaced by wood of density 0.2g/cm^3 . These calculations also demonstrated the sensitivity of the predicted dose-rate in the peaks to the composition of the wood. The calculations with DORT and SAS4 consistently underpredict although the more accurate response function calculated by Diop was used. This discrepancy is not due to a lower neutron source strength, which suggests that the data library used in both these calculations tends to give more attenuation.

The effect of source multiplication was taken into account by using a value of k-eff of 0.15 (2). The majority of participants used this value as a correction factor for the source strengths in the dose-rate calculations; MCNP (6) however takes multiplication into account automatically. UK/AEA (7) used the facility available within MCBEND to determine the secondary source from multiplication and calculated multiplication factors of 1.13 to 1.23, with a mean of 1.17, over the centre of each fuel assembly; with 1.21 and 1.33 at the top and bottom respectively, where the primary source is lower. The mean value of 1.17 is consistent with a value of k-eff of 0.15.

6.0 CONCLUSIONS

Contributions to the TN-12 benchmark have been provided by 8 participants and these involved the use of three codes, FISPIN, APOLLO and ORIGEN, to calculate source strengths and a range of codes to determine dose-rates outside the flask.

6.1 Gamma-ray benchmark

A comparison was made between calculated sources at the mid-height of 2 fuel assemblies and at the top. There was good agreement between participants for source strengths in the important energy group for steel flasks, 2.0 to 2.5MeV; and total source strengths are of the same order of magnitude.

The source from activation of the end fittings was also calculated but there was wide discrepancy in the results. This may be due to interpretation of the information supplied in the specification, averaging of the thermal fluxes, and the activation cross-sections used in the calculation. These uncertainties affect the dose-rate results at the top and bottom of the flask, so that more weight is given to the comparisons at mid-height.

The source strengths calculated were then used in a further calculation to determine the gamma-ray dose-rates outside the flask. In general there was good agreement between the codes and with the experimental results. This shows that the method of modelling axial variation of the burn-up in the source calculation is not important when calculating dose-rates at mid-height and has probably a small effect on the dose-rates at the top and bottom of the flask. UK/AEA had included a fin correction factor of 1.36 for surface results decreasing to 1.19 at 2m (7); however other results show agreement without this factor. Parks et al had shown that the method of modelling the fins had no effect on their results (11). The reasons for these differences have not been established and further investigation is needed. It is of interest to note that smearing of the large fins in the theoretical benchmark (13) did over estimate the attenuation.

The variations in source calculations do not transfer through to the results for dose-rates, presumably because the differences in the predicted attenuations are more significant than those between sources. This is particularly true when it is recognised that the agreement was good for the higher energy sources which are the dominant contributors to the external sources.

6.2 Neutron benchmark

A comparison was made between sources calculated by participants for regions at the mid-height and at the top of 2 fuel assemblies. The source strengths for spontaneous fission were of the same order of magnitude within the range $6.17\text{E}+8$ to $7.56\text{E}+8$ n/s/tonne at mid-height (excluding the UK/BNFL value which is for a larger length of fuel) and $8.54\text{E}+6$ to $2.81\text{E}+7$ n/s/tonne at the top. (All assemblies have similar irradiation histories for the neutron benchmark.) The source from α, n reactions shows more variation but only represents $\sim 2\%$ of the source over the greater part of each assembly, increasing to $\sim 15\%$ at the very top. The rapid variation of neutron source strength with burn-up probably leads to this greater variation at the top of the fuel where participants represented the axial power profile with differing accuracy.

The calculated source strengths were then used in a further calculation to determine the neutron dose-rates outside the flask. The majority of results are in good agreement with experiment at mid-height; however this falls off with distance

suggesting that there is an angular dependence of the response which has not been considered in the response function provided by the 1-D adjoint calculations. When this was calculated by UK/AEA there was better agreement away from the flask. The US results are lower, which cannot be explained.

The results for dose-rates at the top and bottom peaks also vary and this may be due to the composition of balsa used in the calculations or the axial treatment of the source.

6.3 Summary

In general the codes give results which are in excellent agreement with measurements at the mid-height of the flask where the configuration is well defined. At the peaks at the top and bottom of the radial wall there are larger variations in the results which may be due to the greater complexity of the geometry in this region. There are also uncertainties in the fluxes for the production of cobalt activity and in the composition of the balsa wood which detract from the value of the comparisons in these regions for gamma-rays and neutrons respectively.

There were several additional points which could not be resolved by participants within the resources available for this study. One was the discrepancy in the estimate of the effect of using a smeared composition in the modelling of the fins, and another was the reason for the range of values for the cobalt activation.

While the comparisons give confidence in the methods of calculation employed in the study, it is to be hoped that participants will have the opportunity in the future to study in more detail some of these remaining difficulties.

REFERENCES

1. Dent W.
"An FRG Proposal for an International Intercomparison of Codes for Radiation Protection Assessment of Transportation Packages".
NEACRP-L-290
2. Diop C.M., Nimal J.C. , Blum P. and Cagnon R.
TN12 Shipping cask calculations benchmark.
NEACRP-A-961, January 1989
3. Sartori E.
Letter to the participants in the NEACRP TN-12 Shipping Flask Shielding Benchmark:Additional Explanations.
NDB/1479/avt, 5th October 1989
4. Avery A.F. Letter to the participants in the NEACRP TN-12 Shipping Flask Shielding Benchmark:Additional Information 21 November 1989
5. Locke H. F.
NEACRP Intercomparison of codes for the radiation protection assessment of transportation packages.Solutions to problems 5 and 6.
NEACRP-L-338
6. Monti S., Peerani P., Gualdrini G. F. and Burn K. W.
NEACRP Intercomparison of codes for the dosimetric assessment of transport packages.ENEА calculations on the TN12 spent fuel shipping cask.
DRAFT RT/ENEА-AMB()1991
7. Locke H. F.
NEACRP Intercomparison of codes for the shielding assessment of transport packages.Solution for the TN12 Benchmark problem.
AEA-RS-1063
8. La Fuente A. Renard A.
TN12 Shipping cask shielding benchmark
OECD-NEA Intercomparison of codes
BN 63005/095 March 1992
9. Kloosterman J. L.
Gamma benchmark calculations on the TN12 spent fuel shipping cask
IRI-131-89-11
10. Winstanley D. D. Hobson M. J.
NEACRP Intercomparison of codes for the shielding assessment of transport packages.Shielding assessment of TN12 shipping cask
SH2827 Feb 1991 (amendments June 1992)
11. Parks C.V. Broadhead B.L.
US calculations for TN12 shipping cask
April 1991
12. Gewehr K.
Intercomparison of codes for the shielding assessment of transport packages.
Feb 90 and Sept 90

13. Avery A. F. Locke H. F.
NEACRP Intercomparison of codes for the radiation protection assessment of transportation packages. Solutions to problems 1-4.
NEACRP-L-331
14. Kloosterman J.L.
MARMER, a flexible point-kernel shielding code, user manual.
Report IRI 131-89-03, August 1989
15. Devillers C. Dupont C.
MERCURE-IV, Un programme de Monte Carlo a trois dimensions pour l'integration de noyaux ponctuels d'attenuation en ligne droite.
Note CEA-N-1276
16. West J.T. Emmett M.B.
MARS, a multiple array system using combinatorial geometry.
Oak Ridge National Laboratory, Oak Ridge, Tennessee
Report NUREG/CR-0200, Volume 3, Section M9, Dec. 1984
17. Bresard I., Diop C.M. Nimal J.C.
Calcul de debit d'equivalent de dose neutronique a l'exterieur d'un emballage TN12
DMT90/305 SERMA/LEPP/90/1202
18. Shielding assessment of fuel transportation packages
Results of Calculations TN-12 Benchmark
CEA Saclay 12 February 1990
19. Determination of a Helium-3 detector response by a 1D adjoint SN calculation
CEA/DRN/DMT/SERMA/LEPP CEN/SACLAT
20. Sartori E.
Letter to the participants in the NEACRP TN-12 Shipping flask shielding benchmark: Detector Response function for the Neutron case
NDB/90/avt 29 January 1990
21. Locke H. F.
NEACRP Intercomparison of codes for the radiation protection assessment of transportation packages. Calculation of the response function of the Helium-3 detector used in the TN12 benchmark experiments.
NEACRP-L-338

Table 1 Material Compositions

| Material | Location (see figures 1 and 2) | Description | Composition | % by weight | Density (g/cm ³) |
|----------|--|--|---|--|---------------------------------|
| 1 | Container body Closure head Shock absorber shells Basket skirt | Steel equivalent to ASTM-350 grade LF5 steel | Fe Ni Mn Misc. | 96.8 1.4 1.2 0.6 | 7.85 |
| 2 | Copper fin and resin smear | 47.3% polyester resin coated with silicone, 52.7% Cu (by mass) | Cu | 100.0 | 8.93 |
| 2a | Copper fin and resin smear | 48.5% polyester resin coated with silicone, 51.5% Cu (by mass) | <u>Resin</u> H C O Cl Al N B Sb Zn | 5.1 42.3 21.1 14.1 7.2 1.4 1.0 5.7 2.1 | 1.40 |
| 3 | Copper fin and air smear | 12.6% Cu, 87.4% air by volume | Cu | 100.0 | 8.93 |
| 3a | Copper fin and air smear | 12.2% Cu, 87.8% air by volume | | | |
| 4 | Skirt supports | 81.2% steel (AISI 316) 18.8% air (by volume) | <u>Steel</u> Fe Cr Ni Mo Mn Misc. | 67.4 17.0 12.0 2.5 2.0 1.1 | 7.85 |
| 5 | Support shims | 14.5% steel (AISI 304L) 84.5% air (by volume) | <u>Steel</u> Fe Cr Ni Mn Misc. | 67.8 19.0 10.0 2.0 1.2 | 7.85 |
| 6 | Support shims, basket support feet | 13.4% steel (AISI 304L) 86.6% air (by volume) | As 5 | | |
| 7 | Cruciform structure separating basket structures | 14.5% steel (mixture of AISI 309 & 316L, 85.5% air (by volume) | <u>Steel</u> Fe Cr Ni Mo Mn Misc. | 61.4 22.2 13.5 1.7 0.2 1.0 | 7.85 |
| 8 | Basket zones | Aluminium alloy | Al Si Fe Misc. | 86.3 12.2 0.5 1.0 | 2.68 |
| 8a | Basket zones | 90% Al alloy, 10% steel (AISI 316) (by volume) | | | |
| 9 | Basket walls reinforced with stainless steel grids and B4C-Cu plates | 50.3% Al alloy, 26.2% B4C-Cu, 23.5% steel (AISI 321) (by weight) | <u>B4C-Cu</u> Cu B C Misc. | 65.7 27.5 6.6 0.2 | 3.85 |
| 9a | Basket walls reinforced with stainless steel grids and B4C-Cu plates | 37.0% Al alloy, 23.4% B4C-Cu, 39.6% steel (AISI 321) (by weight) | <u>Steel</u> Fe Cr Ni Mn Misc. | 70.4 17.9 9.3 1.5 0.9 | 7.85 |
| 10 | Balsa wood inside shock absorbers | Balsa | H2O | | 0.25 |
| | | Composition used by UK(AEA) and Belgium in n calculations | H O C | 6.5 40.2 53.3 | 0.2(UK) 0.25(Belg.) |

Table 2. Assembly Characteristics.

| Parameter | Value |
|--|--------------------------|
| Configuration | 17 x 17 |
| Assembly pitch (cm) | 21.504 1.7x1.26+0.084 |
| Lattice pitch (cm) | 1.26 |
| Active fuel height (cm) | 365.76 |
| Number of pins | 264 |
| Number of guide tubes | 24 |
| Number of Instrument tubes | 1 |
| External diameter of guide tubes (cm) | 1.224 |
| Guide tube thickness (cm) | 0.042 |
| Guide tube material | Zircaloy 4 |
| Minimum internal diameter of guide tubes (cm) | 1.138 |
| Minimum thickness of Instrumentation tube (cm) | 0.04 |
| Instrumentation tube material | Zircaloy 4 |
| Diameter of sheath (cm) | 0.95 |
| Nominal sheathing tube thickness (cm) | 0.057 |
| Diameter of pellet (cm) | 0.819 |

Table 3. Fuel Assembly Components.

| | | Number per assembly | Mass per assembly (kg) | Material (see table) |
|------------------------|-----------------|---------------------|------------------------|-----------------------|
| <u>SKELETON</u> | | | | |
| Top nozzle | Nozzle | 1 | 6.500 | Z2-CN 18.10 |
| | Flanges | 2 | 0.258 | Z2-CN 18.10 |
| | Flange screws | 2 | 0.020 | Z5-CN 18.10 |
| | Springs | 4 | 0.960 | Inconel 718 |
| | Spring screws | 4 | 0.132 | Inconel 600 |
| Bottom nozzle | Nozzle | 1 | 5.600 | Z2-CN 18.10 |
| | Support screws | 24 | 0.180 | Z5-CN 18.10 |
| Mixing grids | Straps | 6 | 3.660 | Inconel 718 |
| | Sleeves | | 0.795 | Z5-CN 18.10 |
| Top grid | Straps | 1 | 0.510 | Inconel 718 |
| | Sleeves | | 0.290 | Z2-CN 18.10 |
| Bottom grid | Straps | 1 | 0.510 | Inconel 718 |
| | Inserts | | 0.310 | Z2-CN 18.10 |
| Tubes | Guides | 24 | 9.216 | Zircaloy 4 |
| | Instrumentation | 1 | 0.380 | Zircaloy 4 |
| <u>ROD</u> | | | | |
| Clads | Nozzle | 264 | 105.600 | Zircaloy 4 |
| End plugs | Bottom | 264 | 1.637 | Zircaloy 4 |
| | Top | 264 | 1.584 | Zircaloy 4 |
| Fuel pellets | | | 523.400 | UO2 |
| Springs | | 264 | 5.016 | Z5-CN 20.11 |

Table 4. Materials used in each fuel assembly.

| Material | Composition | % by weight | Density (g/cm ³) |
|---------------------------|----------------------------|-----------------------------|------------------------------|
| Z2 CN 18.10 & Z5 CN 18.10 | Fe Cr Ni (+Co) Co | 72.0 18.0 10.0 0.1 | 7.85 |
| Z5 CN 20.11 | Fe Cr Ni (+Co) Co | 69.0 20.0 11.0 0.1 | 7.85 |
| Inconel 718 | Fe Cr Ni (+Co) Co | 29.0 19.0 52.0 0.8 | 8.40 |
| Inconel 600 | Fe Cr Ni (+Co) Co | 8.0 16.0 76.0 0.8 | 8.40 |
| Zr-4 | Fe Cr Zr Sn | 0.2 0.1 98.2 1.5 | 6.55 |

Table 5. Gamma Benchmark. Description of individual fuel Assemblies.

| Position | 1 | 2 | 3 | 4 | 5 | 6 | 7 | 8 | 9 | 10 | 11 | 12 |
|---|--|-----------|-----------|-----------|-----------|-----------|-----------|-----------|-----------|-----------|-----------|-----------|
| Number of cycles | 1 | 1 | 1 | 1 | 1 | 1 | 1 | 2 | 2 | 2 | 2 | 2 |
| Cycle 1 Start date | 24-Oct-77 | 24-Oct-77 | 24-Oct-77 | 24-Oct-77 | 24-Oct-77 | 24-Oct-77 | 24-Oct-77 | 24-Oct-77 | 24-Oct-77 | 24-Oct-77 | 24-Oct-77 | 24-Oct-77 |
| End date | 3-Mar-79 | 3-Mar-79 | 3-Mar-79 | 3-Mar-79 | 3-Mar-79 | 3-Mar-79 | 3-Mar-79 | 3-Mar-79 | 3-Mar-79 | 3-Mar-79 | 3-Mar-79 | 3-Mar-79 |
| Cycle 2 Start date | - | - | - | - | - | - | - | 20-Jul-79 | 20-Jul-79 | 20-Jul-79 | 20-Jul-79 | 20-Jul-79 |
| End date | - | - | - | - | - | - | - | 9-May-80 | 9-May-80 | 9-May-80 | 9-May-80 | 9-May-80 |
| Irradiation duration | see figure 6 | | | | | | | | | | | |
| Burn-up (MWdays/tonne U) | | | | | | | | | | | | |
| Cycle 1 | 16990 | 16990 | 16990 | 17040 | 17040 | 17040 | 17040 | 15300 | 15300 | 15300 | 15020 | 15020 |
| Cycle 2 | - | - | - | - | - | - | - | 9710 | 9710 | 9730 | 10070 | 10070 |
| Axial variation | see table 3 for variation along active part of each assembly | | | | | | | | | | | |
| Mass of U before irradiation (kg/assembly) | 459.970 | 460.230 | 460.940 | 458.910 | 460.940 | 461.200 | 462.170 | 463.250 | 461.730 | 461.465 | 462.260 | 463.490 |
| Mass of U235 before irradiation (kg/assembly) | 9.695 | 9.701 | 9.716 | 9.689 | 9.716 | 9.721 | 9.742 | 11.884 | 11.850 | 11.843 | 11.864 | 11.896 |
| Pin mean linear power density (W/cm) | 197.37 | 197.37 | 197.37 | 197.88 | 197.88 | 197.88 | 197.88 | 170.00 | 170.00 | 170.00 | 170.54 | 170.54 |
| Mean temperature of water (°C) | | | | | | | | | | | | |
| Inlet | 284.2 | 284.2 | 284.2 | 284.2 | 284.2 | 284.2 | 284.2 | 284.2 | 284.2 | 284.2 | 284.2 | 284.2 |
| Outlet | 327.6 | 327.6 | 327.6 | 327.7 | 327.7 | 327.7 | 327.7 | 321.6 | 321.6 | 321.6 | 321.7 | 321.7 |
| Cooling time | End of cooling period : May 27 1981 | | | | | | | | | | | |

94750020

Table 6. Gamma Benchmark. Axial Burn-up distribution.

| DISTRIBUTION | POSITION | | | | | | | | | | | | |
|--|----------|--------|--------|--------|--------|--------|--------|--------|--------|--------|--------|--------|--------|
| | 1 | 2 | 3 | 4 | 5 | 6 | 7 | 8 | 9 | 10 | 11 | 12 | |
| TOP | 4066. | 4091. | 4168. | 2971. | 2966. | 2973. | 2966. | 10920. | 11003. | 10921. | 10968. | 10959. | |
| 57 values corresponding to regular intervals | 6139. | 6232. | 6337. | 4044. | 4035. | 4047. | 4035. | 11551. | 11349. | 11554. | 11433. | 11425. | |
| | 8465. | 8582. | 8650. | 6650. | 6636. | 6656. | 6635. | 14684. | 14501. | 14688. | 14479. | 14468. | |
| | 10540. | 10634. | 10662. | 9613. | 9596. | 9613. | 9592. | 17518. | 17429. | 17525. | 17229. | 17215. | |
| | 12122. | 12187. | 12198. | 11410. | 11391. | 11416. | 11388. | 19714. | 19665. | 19721. | 19495. | 19471. | |
| | 13147. | 13085. | 13083. | 12420. | 12401. | 12425. | 12398. | 20823. | 20899. | 20830. | 20739. | 20726. | |
| | 13327. | 13522. | 13343. | 12964. | 12949. | 12968. | 12945. | 21176. | 21043. | 21186. | 20860. | 20850. | |
| | 15408. | 15565. | 15422. | 15077. | 15063. | 15080. | 15059. | 23818. | 23713. | 23830. | 28527. | 23517. | |
| | 16554. | 16600. | 16492. | 16542. | 16531. | 16545. | 16529. | 25141. | 25109. | 25154. | 24905. | 24897. | |
| | 17293. | 17309. | 17210. | 17422. | 17413. | 17425. | 17411. | 25875. | 25851. | 25889. | 25651. | 25644. | |
| | 17808. | 17794. | 17727. | 17983. | 17976. | 17985. | 17975. | 26378. | 26367. | 26393. | 26188. | 26183. | |
| | 18177. | 18135. | 18098. | 18363. | 18357. | 18364. | 18356. | 26659. | 26655. | 26676. | 26545. | 26542. | |
| | 18411. | 18323. | 18311. | 18597. | 18593. | 18598. | 18592. | 26717. | 26722. | 26735. | 26689. | 26686. | |
| | 18186. | 17914. | 17988. | 18388. | 18387. | 18390. | 18385. | 26054. | 26176. | 26071. | 26180. | 26178. | |
| | 16922. | 17034. | 16890. | 17393. | 17393. | 17393. | 17392. | 24716. | 24626. | 24735. | 24513. | 24513. | |
| | 18437. | 18546. | 18494. | 18630. | 18631. | 18629. | 18631. | 26517. | 26398. | 26538. | 26317. | 26317. | |
| | 19037. | 18984. | 19036. | 19285. | 19287. | 19284. | 19287. | 27258. | 27232. | 27279. | 27170. | 27172. | |
| | 19242. | 19146. | 19238. | 19471. | 19474. | 19470. | 19475. | 27418. | 27419. | 27441. | 27406. | 27408. | |
| | 19337. | 19209. | 19842. | 19557. | 19561. | 19556. | 19562. | 27502. | 27524. | 27525. | 27516. | 27519. | |
| | 19367. | 19213. | 19313. | 19562. | 19566. | 19561. | 19568. | 27497. | 27551. | 27521. | 27500. | 27503. | |
| | 19303. | 19132. | 19174. | 19501. | 19506. | 19499. | 19508. | 27360. | 27454. | 27384. | 27384. | 27387. | |
| | 18859. | 18532. | 18564. | 19033. | 19039. | 19030. | 19040. | 26581. | 26789. | 26604. | 26762. | 26764. | |
| | 17361. | 17442. | 17285. | 17805. | 17812. | 17804. | 17814. | 24950. | 24944. | 24973. | 24918. | 24922. | |
| | 18676. | 18890. | 18698. | 18906. | 18913. | 18903. | 18914. | 26567. | 26453. | 26591. | 26485. | 26491. | |
| | 19201. | 19281. | 19106. | 19484. | 19491. | 19480. | 19492. | 27347. | 27320. | 27371. | 27441. | 27448. | |
| | 19320. | 19400. | 19215. | 19598. | 19606. | 19595. | 19608. | 27511. | 27510. | 27537. | 27669. | 27674. | |
| | 19355. | 19431. | 19271. | 19595. | 19603. | 19592. | 19605. | 27612. | 27645. | 27639. | 27801. | 27806. | |
| | | 19331. | 19363. | 19281. | 19563. | 19572. | 19560. | 19574. | 27606. | 27667. | 27632. | 27819. | 27824. |
| | | 19256. | 19216. | 19234. | 19453. | 19461. | 19449. | 19463. | 27453. | 27535. | 27478. | 27718. | 27723. |
| | | 18873. | 18612. | 18716. | 19018. | 19027. | 19014. | 19029. | 26735. | 26899. | 26760. | 27143. | 27148. |
| | | 17360. | 17455. | 17378. | 17769. | 17777. | 17766. | 17780. | 25061. | 25033. | 25085. | 25260. | 25264. |
| | | 18587. | 18903. | 18744. | 18853. | 18862. | 18849. | 18864. | 26591. | 26419. | 26616. | 26563. | 26571. |
| | | 19109. | 19371. | 19174. | 19503. | 19512. | 19500. | 19514. | 27580. | 27462. | 27606. | 27585. | 27591. |
| | | 19262. | 19542. | 19311. | 19672. | 19681. | 19668. | 19688. | 27836. | 27699. | 27862. | 27779. | 27784. |
| | | 19400. | 19615. | 19440. | 19741. | 19751. | 19737. | 19751. | 27962. | 27828. | 27988. | 27876. | 27881. |
| | | 19503. | 19604. | 19478. | 19707. | 19716. | 19704. | 19718. | 28000. | 27876. | 28026. | 27924. | 27930. |
| | | 19504. | 19491. | 19384. | 19628. | 19637. | 19625. | 19639. | 27920. | 27852. | 27945. | 27892. | 27807. |
| | | 19159. | 18889. | 18902. | 19226. | 19233. | 19222. | 19234. | 27331. | 27422. | 27354. | 27506. | 27511. |
| | | 17625. | 17566. | 17484. | 17877. | 17884. | 17874. | 17885. | 25572. | 25546. | 25594. | 25835. | 25839. |
| | | 18848. | 19053. | 18886. | 18912. | 18919. | 18910. | 18920. | 26867. | 26698. | 26890. | 27041. | 27051. |
| | | 19514. | 19510. | 19349. | 19649. | 19655. | 19647. | 19656. | 27938. | 27884. | 27961. | 28431. | 28439. |
| | | 19644. | 19624. | 19469. | 19805. | 19810. | 19803. | 19811. | 28140. | 28127. | 28162. | 28746. | 28753. |
| | | 19699. | 19667. | 19546. | 19841. | 19845. | 19839. | 19846. | 28214. | 28275. | 28235. | 28795. | 28803. |
| | | 19667. | 19593. | 19543. | 19807. | 19810. | 19805. | 19810. | 28197. | 28298. | 28217. | 28731. | 28739. |
| | | 19495. | 19366. | 19372. | 19614. | 19617. | 19614. | 19617. | 28055. | 28143. | 28075. | 28556. | 28562. |
| | | 18980. | 18655. | 18773. | 19026. | 19027. | 19026. | 19027. | 27424. | 27571. | 27442. | 27935. | 27939. |
| | | 17236. | 17121. | 17107. | 17474. | 17474. | 17475. | 17473. | 25520. | 25549. | 25535. | 25935. | 25937. |
| | | 18061. | 18296. | 18250. | 18174. | 18173. | 18176. | 18172. | 26358. | 26215. | 26372. | 26366. | 26372. |
| | | 18288. | 18417. | 18448. | 18573. | 18570. | 18576. | 18569. | 27167. | 27141. | 27191. | 27325. | 27327. |
| | | 17859. | 18024. | 18069. | 18191. | 18186. | 18194. | 18184. | 26843. | 26847. | 26856. | 26995. | 26995. |
| | | 17197. | 17351. | 17390. | 17505. | 17498. | 17508. | 17496. | 26121. | 26162. | 26132. | 26260. | 26259. |
| | | 16263. | 16330. | 16360. | 16527. | 16518. | 16530. | 16515. | 24991. | 25066. | 25000. | 25112. | 25108. |
| | | 14977. | 14926. | 14962. | 15212. | 15203. | 15216. | 15200. | 23316. | 23436. | 23324. | 23471. | 23465. |
| | | 13326. | 13096. | 13192. | 13510. | 13501. | 13515. | 13498. | 20971. | 21169. | 20973. | 21232. | 21223. |
| | | 11248. | 10817. | 10974. | 11346. | 11337. | 11351. | 11334. | 17913. | 18183. | 17918. | 18299. | 18288. |
| | | 8603. | 8093. | 8254. | 8677. | 8670. | 8681. | 8667. | 14136. | 14423. | 14140. | 14672. | 14659. |
| | BOTTOM | 7120. | 7332. | 7243. | 7230. | 7221. | 7234. | 7220. | 12172. | 12150. | 12173. | 12372. | 12369. |

Table 7. Neutron Benchmark. Irradiation History.

| Cycle | Beginning | End | Full power Equivalent days |
|-----------------------|-----------|-----------|----------------------------|
| 1 | 8-Dec-77 | 6-Jul-79 | 445 |
| 2 | 14-Oct-79 | 9-Aug-80 | 280 |
| 3 | 5-Oct-80 | 29-Aug-81 | 282 |
| Measurement | 7-Jun-83 | 7-Jun-83 | |
| Cooling time 647 days | | | |

Table 8. Neutron Benchmark. Burn-up at the end of each cycle.

| Assembly | End of Cycle 1 | End of Cycle 2 | End of Cycle 3 |
|----------|----------------|----------------|----------------|
| 1 | 14080 | 25209 | 34896 |
| 2 | 14080 | 25209 | 34896 |
| 3 | 15740 | 26829 | 36596 |
| 4 | 15740 | 26829 | 36582 |
| 5 | 14080 | 25498 | 35230 |
| 6 | 15740 | 26829 | 36581 |
| 7 | 14080 | 25498 | 35232 |
| 8 | 14080 | 25498 | 35532 |
| 9 | 15740 | 26829 | 36596 |
| 10 | 14080 | 25209 | 34897 |
| 11 | 15740 | 26828 | 36675 |
| 12 | 14080 | 25497 | 35148 |

Table 9. Neutron Benchmark. Axial Burn-up distribution after the first cycle. (MWd/tonneU)

| Position | 1 | 2 | 3 | 4 | 5 | 6 | 7 | 8 | 9 | 10 | 11 | 12 |
|---|----------|----------|----------|----------|----------|----------|----------|----------|----------|----------|----------|----------|
| Top | 4642.16 | 4368.63 | 6125.10 | 6237.64 | 4490.53 | 6239.97 | 4475.61 | 4501.27 | 6184.68 | 4434.21 | 6256.04 | 4443.65 |
| | 6850.72 | 6042.02 | 6986.51 | 7115.33 | 6425.37 | 7117.39 | 6404.16 | 6440.76 | 7054.63 | 6344.88 | 7136.28 | 6358.95 |
| | 8538.61 | 7989.13 | 8819.16 | 8982.20 | 8235.03 | 8984.46 | 8207.96 | 8255.30 | 8905.24 | 8131.96 | 9008.64 | 8150.18 |
| | 9744.96 | 9463.88 | 10383.42 | 10575.81 | 9570.16 | 10578.13 | 9539.05 | 9594.27 | 10484.92 | 9450.66 | 10606.96 | 9472.04 |
| | 10815.87 | 10624.44 | 11666.72 | 11882.91 | 10681.18 | 11885.29 | 10646.32 | 10708.17 | 11780.85 | 10548.08 | 11917.95 | 10572.48 |
| | 11181.14 | 11198.03 | 12248.86 | 12475.82 | 11147.84 | 12478.05 | 11111.19 | 11176.20 | 12368.75 | 11009.16 | 12512.70 | 11035.29 |
| 57 values corresponding to regular intervals | 11763.57 | 11614.05 | 12810.66 | 13048.19 | 11844.66 | 13050.14 | 11606.37 | 11674.37 | 12936.25 | 11500.22 | 13086.78 | 11528.57 |
| | 13246.31 | 12905.35 | 14525.87 | 14795.48 | 13026.32 | 14797.30 | 12983.18 | 13059.76 | 14668.54 | 12864.83 | 14839.22 | 12397.17 |
| | 13963.69 | 13895.19 | 15353.26 | 15638.37 | 13975.36 | 15639.95 | 13828.75 | 13911.19 | 15504.27 | 13703.15 | 15684.71 | 13738.74 |
| | 14517.44 | 14500.17 | 15997.80 | 16295.25 | 14451.32 | 16296.40 | 14402.32 | 14488.91 | 16155.41 | 14271.86 | 16343.50 | 14310.09 |
| | 14925.74 | 14948.90 | 16469.78 | 16776.38 | 14877.26 | 16777.11 | 14826.68 | 14916.33 | 16632.36 | 14692.59 | 16826.11 | 14732.99 |
| | 15165.75 | 15250.46 | 16788.57 | 17101.50 | 15146.02 | 17101.75 | 15094.46 | 15186.11 | 16954.59 | 14958.12 | 17152.11 | 15000.23 |
| | 15279.19 | 15410.67 | 16980.20 | 17297.05 | 15281.31 | 17296.82 | 15229.16 | 15322.10 | 17148.34 | 15091.87 | 17348.43 | 15135.39 |
| | 14750.88 | 15178.04 | 16508.29 | 16816.70 | 14900.68 | 16816.00 | 14849.39 | 14940.87 | 16672.00 | 14715.82 | 16866.77 | 14759.30 |
| | 14376.78 | 14688.38 | 15949.20 | 16847.60 | 14470.10 | 16846.36 | 14420.74 | 14509.49 | 16107.56 | 14891.21 | 16295.98 | 14334.75 |
| | 15598.16 | 15443.66 | 17243.93 | 17566.96 | 15454.94 | 17565.25 | 15402.53 | 15497.27 | 17415.29 | 15264.10 | 17619.31 | 15311.03 |
| | 15879.75 | 16062.38 | 17534.80 | 17863.58 | 15901.62 | 17861.46 | 15847.55 | 15945.58 | 17709.19 | 15705.20 | 17916.16 | 15754.29 |
| | 16017.14 | 16246.38 | 17736.96 | 18069.80 | 16060.77 | 18067.36 | 16006.27 | 16105.49 | 17913.54 | 15862.54 | 18123.80 | 15912.81 |
| | 16068.60 | 16349.27 | 17864.30 | 18199.85 | 16137.13 | 18197.05 | 16082.51 | 16182.42 | 18042.33 | 15938.09 | 18254.29 | 15989.27 |
| | 16073.54 | 16375.26 | 17872.84 | 18208.82 | 16151.87 | 18205.71 | 16097.21 | 16197.47 | 18051.11 | 15952.69 | 18263.33 | 16004.55 |
| | 15987.09 | 16308.15 | 17757.23 | 18091.35 | 16075.27 | 18087.91 | 16020.99 | 16120.91 | 17934.48 | 15977.12 | 18145.56 | 15929.22 |
| | 15331.66 | 15826.00 | 17082.25 | 17404.02 | 15508.00 | 17400.30 | 15455.36 | 15552.40 | 17252.95 | 15316.65 | 17456.22 | 15367.62 |
| | 14733.00 | 15094.27 | 16251.82 | 16558.11 | 14845.19 | 16554.17 | 14795.33 | 14887.95 | 16414.18 | 14662.59 | 16607.73 | 14712.16 |
| | 15838.03 | 15636.13 | 17570.09 | 17901.50 | 15663.37 | 17897.18 | 15611.42 | 15708.56 | 17745.86 | 15471.02 | 17955.16 | 15523.19 |
| | 16036.53 | 16186.91 | 17937.65 | 18276.02 | 16038.37 | 18271.57 | 15985.11 | 16084.89 | 18117.11 | 15841.26 | 18330.87 | 15895.08 |
| | 16111.33 | 16300.56 | 18126.59 | 18468.66 | 16131.88 | 18463.99 | 16078.34 | 16178.84 | 18308.06 | 15933.61 | 18524.10 | 15988.12 |
| | 16125.27 | 16374.55 | 18260.74 | 18605.37 | 16175.08 | 18600.62 | 16121.45 | 16222.29 | 18443.62 | 15976.33 | 18661.31 | 16031.22 |
| | 16105.44 | 16375.31 | 18259.58 | 18604.21 | 16165.57 | 18599.41 | 16112.04 | 16212.69 | 18442.50 | 15966.97 | 18660.21 | 16022.11 |
| | 16019.75 | 16283.18 | 18105.97 | 18447.78 | 16076.66 | 18442.93 | 16023.44 | 16123.75 | 18287.42 | 15879.18 | 18503.34 | 15934.14 |
| | 15413.15 | 15817.33 | 17437.82 | 17767.02 | 15542.59 | 17762.32 | 15490.85 | 15588.27 | 17612.60 | 15581.42 | 17820.65 | 15404.85 |
| | 14671.97 | 15084.37 | 16442.05 | 16752.56 | 14808.45 | 16747.91 | 14759.55 | 14852.06 | 16606.92 | 14626.75 | 16803.10 | 14678.10 |
| | 15956.55 | 15574.74 | 17738.97 | 18073.94 | 15693.89 | 18068.96 | 15642.63 | 15739.92 | 17916.77 | 15501.62 | 18128.46 | 15555.57 |
| | 16280.64 | 16164.70 | 18026.93 | 18367.21 | 16148.02 | 18362.27 | 16095.06 | 16195.34 | 18207.60 | 15949.95 | 18422.61 | 16005.44 |
| | 16467.14 | 16361.19 | 18193.09 | 18536.29 | 16338.87 | 18531.48 | 16285.22 | 16386.64 | 18375.39 | 16138.43 | 18592.22 | 16194.46 |
| | 16495.18 | 16520.76 | 18289.41 | 18634.14 | 16431.98 | 18629.54 | 16377.94 | 16479.90 | 18472.59 | 16230.35 | 18690.44 | 16286.62 |
| | 16424.03 | 16622.50 | 18291.34 | 18635.90 | 16446.90 | 18631.44 | 16392.66 | 16494.71 | 18474.48 | 16244.98 | 18692.21 | 16301.13 |
| | 16302.59 | 16554.06 | 18240.51 | 18583.92 | 16352.61 | 18579.64 | 16298.53 | 16399.93 | 18423.09 | 16151.72 | 18640.07 | 16207.36 |
| | 15680.54 | 16100.57 | 17693.57 | 18026.36 | 15817.18 | 18022.50 | 15764.47 | 15862.85 | 17870.66 | 15622.56 | 18080.89 | 15676.30 |
| | 14837.06 | 15329.71 | 16613.00 | 16925.25 | 15013.48 | 16921.75 | 14963.61 | 15056.63 | 16779.21 | 14829.05 | 16976.41 | 14880.04 |
| | 16086.31 | 15780.45 | 17987.84 | 18325.52 | 15862.13 | 18322.19 | 15810.04 | 15907.26 | 18167.63 | 15667.54 | 18380.88 | 15720.50 |
| | 16349.19 | 16434.82 | 18282.94 | 18625.71 | 16318.08 | 18622.75 | 16264.03 | 16364.31 | 18465.48 | 16117.53 | 18682.00 | 16171.63 |
| | 16508.10 | 16553.71 | 18409.20 | 18753.98 | 16456.93 | 18751.34 | 16402.30 | 16503.34 | 18592.93 | 16254.51 | 18810.61 | 16308.84 |
| | 16573.24 | 16556.45 | 18468.32 | 18813.77 | 16491.66 | 18811.55 | 16436.82 | 16537.79 | 18652.46 | 16288.59 | 18870.58 | 16342.24 |
| | 16518.66 | 16460.08 | 18437.18 | 18781.59 | 16417.32 | 18779.84 | 16362.61 | 16462.84 | 18620.81 | 16214.96 | 18838.29 | 16267.59 |
| | 16315.68 | 16306.62 | 18267.28 | 18607.87 | 16240.23 | 18606.77 | 16186.10 | 16284.93 | 18448.89 | 16039.94 | 18664.05 | 16091.09 |
| | 15584.60 | 15837.57 | 17612.34 | 17940.22 | 15643.04 | 17939.70 | 15590.48 | 15685.68 | 17787.23 | 15449.71 | 17994.37 | 15498.73 |
| | 14514.59 | 14953.58 | 16254.83 | 16557.02 | 14670.25 | 16556.96 | 14621.09 | 14709.81 | 16416.02 | 14489.01 | 16606.93 | 14533.87 |
| | 15433.00 | 15098.77 | 17326.42 | 17648.03 | 15202.89 | 17648.62 | 15152.82 | 15243.32 | 17497.89 | 15015.29 | 17701.12 | 15060.18 |
| | 15255.07 | 15422.42 | 17205.70 | 17524.48 | 15275.44 | 17525.77 | 15224.89 | 15315.80 | 17375.65 | 15086.48 | 17577.21 | 15130.48 |
| | 14858.46 | 15101.55 | 16759.33 | 17069.25 | 14919.00 | 17071.22 | 14869.73 | 14958.09 | 16924.57 | 14734.25 | 17120.66 | 14776.15 |
| | 14212.01 | 14564.90 | 16050.70 | 16347.10 | 14330.29 | 16349.52 | 14283.04 | 14367.56 | 16208.68 | 14152.59 | 16396.26 | 14191.78 |
| | 13354.26 | 13791.91 | 15041.43 | 15318.71 | 13518.75 | 15321.61 | 13474.22 | 13553.64 | 15189.19 | 13350.89 | 15364.84 | 13386.80 |
| | 12194.78 | 12725.90 | 13658.53 | 13910.08 | 12410.89 | 13913.08 | 12370.10 | 12442.78 | 13792.51 | 12256.58 | 13951.93 | 12288.63 |
| | 10659.74 | 11319.87 | 11876.93 | 12095.42 | 10946.49 | 12098.41 | 10910.43 | 10974.45 | 11993.26 | 10810.12 | 12131.82 | 10837.56 |
| | 8716.46 | 9539.96 | 9707.48 | 9885.98 | 9092.20 | 9888.62 | 9062.09 | 9115.35 | 9802.45 | 8978.65 | 9915.59 | 9000.76 |
| | 6370.85 | 7414.63 | 7291.57 | 7425.41 | 6865.05 | 7427.66 | 6842.13 | 6882.50 | 7362.82 | 6779.09 | 7447.73 | 6795.32 |
| Bottom | 6729.95 | 6363.45 | 8094.18 | 8242.36 | 6524.23 | 8245.26 | 6504.39 | 6540.39 | 8173.05 | 6443.23 | 8267.19 | 6457.81 |

Table 9 cont. Neutron Benchmark. Axial Burn-up distribution after the second cycle. (MWd/tonneU)

| Position | 1 | 2 | 3 | 4 | 5 | 6 | 7 | 8 | 9 | 10 | 11 | 12 |
|----------|----------|----------|----------|----------|----------|----------|----------|----------|----------|----------|----------|----------|
| Top | 9944.91 | 9739.10 | 12982.46 | 13022.71 | 9951.68 | 12999.39 | 9968.62 | 10026.57 | 13017.34 | 9762.65 | 13082.48 | 9956.34 |
| | 13866.41 | 13146.47 | 13810.60 | 14011.34 | 13115.97 | 13843.35 | 13133.79 | 13210.12 | 13854.01 | 13394.25 | 13928.40 | 13112.69 |
| | 17086.84 | 16644.36 | 17276.36 | 17521.43 | 16579.93 | 17319.80 | 16601.53 | 16698.42 | 17331.73 | 16721.36 | 17425.91 | 16573.78 |
| | 19293.60 | 19133.34 | 20173.25 | 20427.57 | 19178.74 | 20226.79 | 19203.68 | 19315.92 | 20239.26 | 19045.55 | 20350.34 | 19171.20 |
| | 21169.26 | 21108.63 | 22347.54 | 22584.32 | 21160.74 | 22411.98 | 21187.03 | 21311.06 | 22423.10 | 20951.90 | 22547.80 | 21150.79 |
| | 21694.25 | 21843.71 | 23152.46 | 23343.86 | 21763.01 | 23223.99 | 21788.93 | 21916.95 | 23233.02 | 21573.91 | 23363.73 | 21751.10 |
| | 22097.44 | 22078.50 | 23497.00 | 23707.36 | 22377.66 | 23582.18 | 22401.89 | 22533.78 | 23584.31 | 21985.15 | 23721.68 | 22362.68 |
| | 24662.05 | 24465.04 | 26271.91 | 26527.22 | 24834.11 | 26373.36 | 24859.84 | 25006.58 | 26372.22 | 24336.70 | 26528.38 | 24816.15 |
| | 25707.79 | 25787.32 | 27461.29 | 27713.33 | 26063.38 | 27572.98 | 26087.87 | 26242.72 | 27568.90 | 25505.08 | 27734.15 | 26041.53 |
| | 26382.14 | 26514.35 | 28231.95 | 28486.30 | 26821.40 | 28353.61 | 26844.57 | 27004.67 | 28345.63 | 26195.02 | 28518.39 | 26796.65 |
| | 26834.13 | 27007.29 | 28748.20 | 28999.91 | 27333.11 | 28877.86 | 27355.19 | 27518.88 | 28866.65 | 26659.74 | 29044.98 | 27306.13 |
| | 27063.72 | 27288.27 | 29034.22 | 29289.67 | 27609.00 | 29170.16 | 27630.14 | 27795.89 | 29156.19 | 26914.82 | 29338.44 | 27580.56 |
| | 27074.03 | 27354.00 | 29123.42 | 29392.40 | 27661.46 | 29264.30 | 27681.53 | 27848.09 | 29247.86 | 26944.97 | 29432.73 | 27632.11 |
| | 26143.02 | 26713.41 | 28242.82 | 28514.62 | 26788.25 | 28380.33 | 26801.29 | 26963.44 | 28364.07 | 26164.33 | 28544.01 | 26753.77 |
| | 24948.63 | 25393.55 | 26820.23 | 27105.12 | 25721.83 | 26960.07 | 25738.13 | 25893.87 | 26939.50 | 24915.66 | 27114.26 | 25692.48 |
| | 27002.87 | 26992.10 | 28835.46 | 29144.55 | 27524.25 | 28088.93 | 27542.25 | 27708.84 | 28964.92 | 26725.24 | 29164.61 | 27494.02 |
| | 27511.16 | 27840.51 | 29339.20 | 29607.91 | 28188.67 | 29495.00 | 28206.29 | 28377.43 | 29470.92 | 27394.17 | 29664.18 | 28157.07 |
| | 27694.17 | 28070.82 | 29524.91 | 29785.43 | 28393.01 | 29684.70 | 28410.47 | 28583.08 | 29658.63 | 27597.40 | 29854.81 | 28381.23 |
| | 27778.89 | 28207.46 | 29637.84 | 29898.77 | 28465.13 | 29800.24 | 28502.56 | 28675.96 | 29773.23 | 27706.35 | 29971.05 | 28453.61 |
| | 27773.39 | 28222.92 | 29625.53 | 29878.56 | 28481.43 | 29788.37 | 28498.72 | 28672.35 | 29761.18 | 27710.45 | 29959.42 | 28450.27 |
| | 27606.98 | 28074.91 | 29469.74 | 29727.54 | 28332.68 | 29631.02 | 28349.93 | 28522.81 | 29604.50 | 27554.64 | 29801.78 | 28302.14 |
| | 26616.25 | 27253.12 | 28532.60 | 28800.52 | 27378.78 | 28684.89 | 27395.41 | 27563.12 | 28661.63 | 26657.29 | 28851.41 | 27350.26 |
| | 25114.77 | 25607.48 | 26863.12 | 27138.06 | 25970.75 | 27012.29 | 25985.83 | 26144.73 | 26987.20 | 25096.23 | 27168.37 | 25942.61 |
| | 26983.70 | 26916.99 | 28838.86 | 29173.35 | 27600.11 | 29003.06 | 27617.82 | 27786.09 | 28973.59 | 26672.03 | 29170.04 | 27572.46 |
| | 27499.99 | 27795.76 | 29588.98 | 29930.31 | 28281.74 | 29754.57 | 28299.93 | 28472.63 | 29726.05 | 27361.79 | 29926.64 | 28253.86 |
| | 27657.45 | 27993.25 | 29852.04 | 30194.87 | 28452.40 | 30020.12 | 28470.77 | 28644.65 | 29990.83 | 27537.25 | 30193.78 | 28424.82 |
| | 27738.39 | 28135.19 | 30015.47 | 30349.07 | 28543.14 | 30185.62 | 28561.70 | 28736.20 | 30155.52 | 27647.29 | 30360.22 | 28515.92 |
| | 27761.44 | 28179.51 | 30023.91 | 30342.93 | 28547.12 | 30193.91 | 28565.88 | 28740.48 | 30163.94 | 27681.07 | 30368.75 | 28520.46 |
| | 27643.86 | 28055.21 | 29831.73 | 30145.96 | 28414.99 | 29999.41 | 28433.79 | 28607.61 | 29970.38 | 27561.33 | 30173.54 | 28388.85 |
| | 26777.48 | 27326.10 | 28950.56 | 29252.84 | 27980.97 | 29108.66 | 27599.51 | 27768.66 | 29083.12 | 26772.49 | 29278.70 | 27556.79 |
| | 25131.22 | 25676.87 | 27086.66 | 27366.21 | 26014.79 | 27238.76 | 26031.34 | 26190.66 | 27212.57 | 25139.61 | 27397.21 | 25990.20 |
| | 27065.94 | 26825.78 | 28926.46 | 29267.33 | 27658.02 | 29094.91 | 27676.62 | 27845.28 | 29063.20 | 26666.66 | 29263.04 | 27632.61 |
| | 27911.85 | 27843.10 | 29729.91 | 30062.80 | 28510.17 | 29896.34 | 28529.38 | 28703.36 | 29867.62 | 27538.91 | 30070.41 | 28484.27 |
| | 28103.44 | 28146.15 | 30003.80 | 30355.70 | 28807.66 | 30171.78 | 28826.81 | 29002.59 | 30142.73 | 27833.11 | 30347.38 | 28780.95 |
| | 28229.21 | 28404.79 | 30173.41 | 30540.18 | 28965.54 | 30342.10 | 28984.68 | 29161.38 | 30312.91 | 28023.23 | 30518.61 | 28938.51 |
| | 28243.97 | 28593.62 | 30198.32 | 30555.59 | 29006.87 | 30366.70 | 29025.97 | 29202.93 | 30337.68 | 28124.23 | 30543.35 | 28979.69 |
| | 28119.98 | 28522.71 | 30115.11 | 30448.04 | 28887.11 | 30282.98 | 28906.22 | 29082.38 | 30253.96 | 28028.52 | 30459.02 | 28860.23 |
| | 27292.37 | 27860.97 | 29365.81 | 29646.93 | 28121.65 | 29526.21 | 28140.79 | 28312.57 | 29499.75 | 27292.84 | 29698.27 | 28096.96 |
| | 25530.48 | 26160.05 | 27444.92 | 27672.12 | 26434.75 | 27597.19 | 26651.57 | 26612.78 | 27571.02 | 25576.57 | 27757.36 | 26409.21 |
| | 27303.52 | 27141.47 | 29166.81 | 29480.33 | 27917.60 | 29339.80 | 27935.92 | 28105.14 | 29305.14 | 26941.25 | 29507.46 | 27889.88 |
| | 28112.43 | 28349.04 | 30040.70 | 30378.19 | 28894.59 | 30210.87 | 28914.00 | 29089.35 | 30179.62 | 27940.17 | 30384.84 | 28866.98 |
| | 28400.14 | 28598.52 | 30279.64 | 30677.34 | 29175.70 | 30450.56 | 29195.36 | 29372.32 | 30419.30 | 28206.66 | 30625.72 | 29147.61 |
| | 28517.16 | 28653.92 | 30425.78 | 30842.35 | 29299.74 | 30596.59 | 29319.71 | 29497.15 | 30565.52 | 28292.92 | 30772.41 | 29271.39 |
| | 28509.71 | 28605.40 | 30467.71 | 30866.54 | 29274.44 | 30636.95 | 29294.84 | 29471.81 | 30606.65 | 28266.66 | 30812.93 | 29246.26 |
| | 28346.34 | 28492.17 | 30336.17 | 30702.70 | 29095.92 | 30501.72 | 29116.87 | 29292.33 | 30472.91 | 28131.42 | 30676.97 | 29068.32 |
| | 27550.80 | 27957.87 | 29642.57 | 29966.75 | 28340.39 | 29796.46 | 28362.00 | 28532.98 | 29772.63 | 27476.46 | 29968.79 | 28315.64 |
| | 26575.19 | 26257.98 | 27538.63 | 27793.59 | 26470.94 | 27677.96 | 26490.71 | 26649.85 | 27657.73 | 25706.28 | 27838.28 | 26446.16 |
| | 26988.34 | 26803.39 | 28822.80 | 29137.62 | 27448.78 | 28979.49 | 27470.24 | 27633.87 | 28951.48 | 25629.01 | 29144.48 | 27421.91 |
| | 27512.82 | 27838.45 | 29501.41 | 29741.60 | 28097.59 | 29644.50 | 28121.94 | 28289.31 | 29625.50 | 27405.83 | 29816.43 | 28073.93 |
| | 27212.39 | 27615.50 | 29160.96 | 29374.51 | 27741.44 | 29294.55 | 27767.07 | 27931.84 | 29280.02 | 27150.41 | 29465.61 | 27719.90 |
| | 26508.04 | 27020.44 | 28368.42 | 28549.10 | 26997.68 | 28490.30 | 27024.43 | 27184.37 | 28480.56 | 26510.53 | 28657.94 | 26979.01 |
| | 25398.05 | 25992.18 | 27105.67 | 27425.03 | 25953.85 | 27212.64 | 25881.36 | 26034.18 | 27208.52 | 25455.23 | 27374.37 | 25838.59 |
| | 23742.00 | 24423.28 | 25259.93 | 25384.61 | 24160.50 | 25348.16 | 24188.34 | 24330.85 | 25350.80 | 23986.17 | 25501.07 | 24149.40 |
| | 21372.67 | 22712.27 | 22696.21 | 22795.12 | 21774.37 | 22762.68 | 21801.55 | 21929.87 | 22772.32 | 21576.74 | 22902.57 | 21767.88 |
| | 18198.81 | 19145.68 | 19368.73 | 19450.58 | 18580.90 | 19411.59 | 18606.21 | 18715.74 | 19427.30 | 18508.41 | 19533.72 | 18579.23 |
| | 14076.47 | 15220.42 | 15262.02 | 15312.75 | 14481.38 | 15284.05 | 14502.93 | 14588.43 | 15303.60 | 14522.89 | 15382.73 | 14483.69 |
| Bottom | 12758.70 | 12471.71 | 14291.76 | 14470.16 | 12639.98 | 14354.68 | 12655.87 | 12728.10 | 14347.83 | 12502.47 | 14437.82 | 12631.48 |

Table 9 cont. Neutron Benchmark. Axial Burn-up distribution after the third cycle. (Mwd/tonneU)

| Position | 1 | 2 | 3 | 4 | 5 | 6 | 7 | 8 | 9 | 10 | 11 | 12 |
|----------|----------|----------|----------|----------|----------|----------|----------|----------|----------|----------|----------|----------|
| Top | 13880.83 | 13695.90 | 17903.03 | 18238.45 | 14862.13 | 17852.10 | 14492.66 | 15424.69 | 17888.28 | 13640.58 | 18030.07 | 14930.45 |
| | 18905.24 | 18212.08 | 19414.56 | 19488.05 | 18703.20 | 19370.10 | 18993.54 | 18630.80 | 19401.39 | 18357.94 | 19563.47 | 18772.99 |
| | 23359.22 | 22850.06 | 23930.57 | 23986.25 | 23355.10 | 23882.51 | 23572.21 | 23407.87 | 23918.98 | 22855.27 | 24117.46 | 23437.87 |
| | 26473.42 | 26351.29 | 27577.12 | 27601.89 | 26903.02 | 27529.08 | 26997.63 | 27120.92 | 27568.90 | 26244.47 | 27796.23 | 26997.15 |
| | 29049.25 | 29030.37 | 30355.73 | 30463.22 | 29572.82 | 30310.31 | 29642.25 | 29343.52 | 30351.18 | 28899.87 | 30601.55 | 29673.55 |
| | 29779.75 | 29971.86 | 31110.34 | 31449.41 | 30341.68 | 31072.76 | 30380.81 | 30648.41 | 31111.66 | 29801.37 | 31367.24 | 30442.01 |
| | 30171.08 | 30195.00 | 31833.17 | 31671.29 | 30840.09 | 31804.04 | 30949.12 | 31075.91 | 31837.45 | 29940.51 | 32105.95 | 30936.78 |
| | 33702.53 | 33553.20 | 35461.03 | 35549.62 | 34239.41 | 35436.56 | 34273.12 | 34587.67 | 35489.96 | 33477.25 | 35770.77 | 34345.71 |
| | 35177.98 | 35307.38 | 37009.91 | 37171.39 | 35865.64 | 36990.67 | 35919.56 | 36206.39 | 37022.69 | 35087.47 | 37338.50 | 35973.44 |
| | 36076.87 | 36260.10 | 38006.62 | 38183.75 | 36806.03 | 37994.41 | 36854.65 | 37157.80 | 38023.51 | 36007.17 | 38350.48 | 36913.51 |
| | 36668.64 | 36893.49 | 38683.28 | 38869.75 | 37439.86 | 38676.94 | 37478.61 | 37805.80 | 38703.50 | 36623.64 | 39038.80 | 37546.86 |
| | 36979.71 | 37266.36 | 39057.18 | 39262.75 | 37783.89 | 39056.00 | 37823.14 | 38150.86 | 39080.22 | 36949.82 | 39421.00 | 37890.55 |
| | 36995.81 | 37327.86 | 39133.32 | 39410.29 | 37829.42 | 39137.28 | 37871.73 | 38191.52 | 39159.11 | 36993.63 | 39502.46 | 37935.27 |
| | 35755.12 | 36375.83 | 37720.10 | 38298.28 | 36643.31 | 37728.09 | 36661.80 | 37014.39 | 37748.26 | 35978.88 | 38078.43 | 36745.08 |
| | 33995.17 | 34487.50 | 36126.69 | 36148.39 | 34922.03 | 36139.32 | 35015.95 | 35194.61 | 36154.52 | 33968.87 | 36477.07 | 35015.87 |
| | 36755.23 | 36795.57 | 38824.69 | 38978.89 | 37409.57 | 38841.23 | 37429.54 | 37784.82 | 38855.58 | 36556.24 | 39204.00 | 37511.25 |
| | 37599.48 | 37981.67 | 39517.32 | 39720.99 | 38418.97 | 39534.07 | 38509.33 | 38733.25 | 39549.13 | 37550.04 | 39904.11 | 38523.93 |
| | 37882.43 | 38312.43 | 39778.08 | 39977.44 | 38703.33 | 39797.83 | 38793.87 | 39021.35 | 39811.42 | 37840.17 | 40170.43 | 38809.75 |
| | 38030.08 | 38512.30 | 39960.14 | 40165.34 | 38833.32 | 39981.57 | 38903.80 | 39172.33 | 39994.32 | 38000.66 | 40356.37 | 38940.06 |
| | 38038.13 | 38541.36 | 39973.59 | 40193.08 | 38833.56 | 39995.12 | 38887.80 | 39188.67 | 40007.84 | 38025.37 | 40370.80 | 38940.77 |
| | 37833.34 | 38354.76 | 39769.45 | 40045.89 | 38643.35 | 39790.12 | 38684.50 | 39009.51 | 39803.38 | 37850.80 | 40164.70 | 38750.68 |
| | 36539.59 | 37228.28 | 38369.12 | 38933.16 | 37401.71 | 38387.15 | 37423.29 | 37775.73 | 38402.02 | 36725.81 | 38748.55 | 37057.30 |
| | 34367.19 | 34908.30 | 36339.44 | 36448.82 | 35224.92 | 36359.22 | 35376.34 | 35440.86 | 36370.87 | 34309.12 | 36703.22 | 35320.22 |
| | 36828.00 | 36812.80 | 39018.81 | 39153.15 | 37409.83 | 39044.03 | 37414.04 | 37800.69 | 39053.90 | 36561.41 | 39412.77 | 37513.53 |
| | 37727.94 | 38077.21 | 40058.14 | 40328.76 | 38502.86 | 40080.84 | 38524.14 | 38889.86 | 40092.79 | 37666.75 | 40460.40 | 38611.81 |
| | 37963.98 | 38353.68 | 40415.34 | 40674.35 | 38760.92 | 40439.23 | 38777.57 | 39155.46 | 40450.83 | 37928.46 | 40822.31 | 38871.28 |
| | 38091.68 | 38542.62 | 40625.67 | 40859.35 | 38902.80 | 40650.98 | 38914.85 | 39304.64 | 40661.95 | 38099.15 | 41035.96 | 39014.27 |
| | 38140.68 | 38613.00 | 40634.09 | 40957.77 | 38931.12 | 40659.24 | 38943.63 | 39333.35 | 40670.84 | 38163.04 | 41044.46 | 39043.33 |
| | 38018.89 | 38484.47 | 40383.00 | 40658.71 | 38780.18 | 40406.60 | 38794.19 | 39179.56 | 40418.46 | 38044.18 | 40789.97 | 38892.66 |
| | 36912.14 | 37513.64 | 39067.88 | 39618.96 | 37726.95 | 39087.86 | 37724.11 | 38133.63 | 39101.59 | 37086.71 | 39458.62 | 37838.46 |
| | 34561.15 | 35156.08 | 36669.67 | 36872.05 | 35411.04 | 36690.88 | 35553.59 | 35842.23 | 36701.94 | 34575.02 | 37039.68 | 35512.07 |
| | 36978.44 | 36790.13 | 39216.18 | 39366.80 | 37486.37 | 39244.04 | 37518.87 | 37851.26 | 39252.12 | 36605.11 | 39616.27 | 37592.45 |
| | 38199.98 | 38285.56 | 40369.37 | 40713.87 | 38908.11 | 40390.40 | 38999.06 | 39231.13 | 40402.85 | 37949.06 | 40775.42 | 39021.11 |
| | 38603.21 | 38700.84 | 40774.29 | 41169.65 | 39312.27 | 40795.03 | 39410.42 | 39631.49 | 40807.64 | 38351.91 | 41184.09 | 39425.80 |
| | 38805.46 | 39036.35 | 41036.57 | 41460.61 | 39500.11 | 41056.73 | 39597.29 | 39822.23 | 41069.52 | 38613.75 | 41448.48 | 39613.62 |
| | 38847.62 | 39252.75 | 41101.91 | 41516.40 | 39540.30 | 41121.15 | 39626.42 | 39873.43 | 41134.29 | 38749.88 | 41513.80 | 39653.60 |
| | 38693.35 | 39151.40 | 40970.63 | 41366.48 | 39377.35 | 40989.96 | 39444.39 | 39728.25 | 41002.91 | 38650.05 | 41380.98 | 39490.29 |
| | 37644.37 | 38267.07 | 39859.58 | 40361.00 | 38407.73 | 39876.42 | 38432.27 | 38793.21 | 39890.55 | 37763.67 | 40256.23 | 38520.11 |
| | 35161.64 | 35841.54 | 37232.28 | 37505.89 | 35877.28 | 37250.59 | 36115.18 | 36218.52 | 37862.38 | 35203.07 | 37604.70 | 36078.80 |
| | 37213.61 | 37103.50 | 39590.12 | 39361.18 | 37671.91 | 39620.33 | 37679.44 | 38060.87 | 39625.82 | 36873.51 | 39994.14 | 37774.09 |
| | 38576.95 | 38868.39 | 40859.64 | 41111.40 | 39268.15 | 40881.57 | 39297.55 | 39655.08 | 40891.97 | 38492.87 | 41269.28 | 39378.41 |
| | 38951.76 | 39205.45 | 41203.55 | 41544.29 | 39670.34 | 41224.71 | 39704.40 | 40057.09 | 41235.45 | 38839.84 | 41615.51 | 39781.56 |
| | 39107.74 | 39300.05 | 41410.25 | 41778.48 | 39843.48 | 41430.42 | 39875.79 | 40233.79 | 41441.51 | 38951.41 | 41822.34 | 39954.90 |
| | 39113.16 | 39264.50 | 41447.74 | 41811.48 | 39826.13 | 41466.32 | 39853.45 | 40222.25 | 41478.08 | 38911.05 | 41858.55 | 39937.66 |
| | 38926.87 | 39128.25 | 41251.08 | 41601.19 | 39613.69 | 41266.79 | 39652.46 | 39996.82 | 41279.72 | 38743.23 | 41656.77 | 39725.15 |
| | 37944.35 | 38405.96 | 40239.63 | 40723.30 | 38680.73 | 40248.00 | 38699.45 | 39077.32 | 40264.61 | 37958.62 | 40628.57 | 38792.55 |
| | 35359.03 | 35992.63 | 37290.81 | 37705.93 | 36109.54 | 37296.16 | 36220.20 | 36383.89 | 37313.18 | 35403.24 | 37648.05 | 36211.90 |
| | 36733.21 | 36599.59 | 39069.36 | 39109.11 | 37088.92 | 39085.13 | 37078.24 | 37495.10 | 39095.91 | 36390.30 | 39450.85 | 37169.21 |
| | 37806.06 | 38186.12 | 40108.06 | 40296.35 | 38371.47 | 40105.20 | 38359.75 | 38799.94 | 40126.23 | 37826.66 | 40484.45 | 38482.96 |
| | 37451.24 | 37908.36 | 39694.52 | 39893.66 | 38041.65 | 39683.09 | 38010.34 | 38490.98 | 39708.16 | 37545.29 | 40059.64 | 38155.32 |
| | 36551.39 | 37116.82 | 38665.49 | 38863.78 | 37189.77 | 38645.55 | 37139.67 | 37652.88 | 38674.34 | 36738.51 | 39013.61 | 37804.62 |
| | 35119.10 | 35764.65 | 37013.98 | 37199.55 | 35794.27 | 36984.41 | 35744.52 | 36246.88 | 37017.20 | 35390.01 | 37338.55 | 35909.00 |
| | 32968.99 | 33699.12 | 34575.32 | 34815.99 | 33640.27 | 34535.12 | 33609.21 | 34055.27 | 34572.28 | 33290.43 | 34868.50 | 33752.91 |
| | 29841.45 | 30685.93 | 31152.14 | 31467.88 | 30552.09 | 31101.98 | 30544.83 | 30913.73 | 31142.81 | 30239.75 | 31405.30 | 30659.96 |
| | 25633.01 | 26619.49 | 26556.74 | 27086.02 | 26315.82 | 26599.08 | 26346.56 | 26595.91 | 26642.07 | 26142.83 | 26861.78 | 26414.71 |
| | 20096.80 | 21272.94 | 20952.43 | 21531.99 | 20781.93 | 20895.99 | 20846.08 | 20968.26 | 20936.43 | 20757.90 | 21104.29 | 20865.97 |
| Bottom | 17437.91 | 17175.78 | 18826.94 | 19142.17 | 17411.98 | 18927.27 | 17532.59 | 17487.01 | 18836.91 | 17059.26 | 18997.68 | 17465.39 |

54770025

Table 10. Gamma Benchmark. Gamma-ray source spectrum.

Assembly 5 Mid height of the active fuel (burn up=19461 MWdays/tonne)

| Group boundaries | | Gamma-ray source (MeV/s/tonne) | | | | | | | |
|---------------------------|---------------------------|--------------------------------|------------|-------------|------------|------------|------------|------------|------------|
| E _{max} (MeV) | E _{min} (MeV) | UK(AEA) | UK(BNFL) | Netherlands | Germany | Italy | France | USA | Belgium* |
| 4.00 | 3.50 | } 2.73E+11 | } 1.70E+11 | - | 1.81E+08 | } 3.40E+11 | } 2.50E+12 | } 3.37E+11 | } 2.10E+12 |
| 3.50 | 3.00 | | | 1.68E+11 | 3.62E+11 | | | | |
| 3.00 | 2.50 | } 1.45E+12 | } 1.40E+12 | } 1.38E+12 | } 1.89E+12 | } 2.21E+12 | } 1.10E+14 | } 2.18E+12 | } 1.28E+14 |
| 2.50 | 2.20 | } 9.55E+13 | } 9.60E+13 | } 1.02E+14 | } 2.01E+12 | | | | |
| 2.20 | 2.00 | } 6.92E+12 | } 6.80E+12 | } 6.40E+12 | } 1.03E+14 | } 2.09E+13 | } 1.11E+14 | } 2.06E+13 | } 3.39E+13 |
| 2.00 | 1.80 | | | | | | | | |
| 1.80 | 1.66 | } 4.25E+13 | } 4.10E+13 | } 1.31E+13 | } 1.42E+14 | } 1.30E+14 | } 1.94E+14 | } 1.24E+14 | } 9.36E+14 |
| 1.66 | 1.50 | | | | | | | | |
| 1.50 | 1.44 | } 1.56E+14 | } 1.20E+14 | } 3.70E+14 | } 3.05E+14 | } 2.97E+14 | } 1.06E+15 | } 2.73E+14 | } 1.39E+15 |
| 1.44 | 1.33 | | | | | | | | |
| 1.33 | 1.22 | } 1.64E+14 | } 1.50E+14 | } 4.42E+14 | } 4.35E+15 | } 6.26E+14 | } 2.90E+15 | } 2.57E+15 | } 3.65E+15 |
| 1.22 | 1.00 | | | | | | | | |
| 1.00 | 0.80 | } 1.86E+14 | } 1.40E+14 | } 1.32E+14 | } 4.35E+15 | } 2.62E+15 | } 2.90E+15 | } 2.57E+15 | } 3.65E+15 |
| 0.80 | 0.70 | | | | | | | | |
| 0.70 | 0.60 | } 3.90E+15 | } 3.10E+15 | } 2.24E+15 | } 4.35E+15 | } 2.62E+15 | } 2.90E+15 | } 2.57E+15 | } 3.65E+15 |
| 0.60 | 0.51 | | | | | | | | |
| 0.51 | 0.40 | } 6.73E+14 | } 5.80E+14 | } 5.29E+14 | } 1.04E+15 | } 1.13E+15 | } 1.12E+15 | } 1.12E+15 | } 7.59E+13 |
| 0.40 | 0.30 | | | | | | | | |
| 0.40 | 0.30 | } 1.40E+12 | } 1.10E+12 | } 3.44E+13 | } 1.04E+15 | } 1.48E+14 | } 1.45E+14 | } 1.45E+14 | } 3.97E+13 |
| 0.30 | 0.20 | | | | | | | | |
| 0.30 | 0.20 | } 3.03E+12 | } 2.30E+12 | } 1.14E+12 | } 1.04E+15 | } 1.37E+14 | } 1.34E+14 | } 1.34E+14 | } 1.23E+14 |
| 0.20 | 0.10 | | | | | | | | |
| 0.20 | 0.10 | } 9.65E+13 | } 9.50E+13 | | } 1.04E+15 | } 3.22E+14 | } 3.15E+14 | } 3.15E+14 | } 1.23E+14 |
| 0.10 | 0.05 | | | | | | | | |
| 0.10 | 0.05 | } 9.02E+12 | | | } 1.04E+15 | } 1.68E+14 | } 1.66E+14 | } 1.66E+14 | } 1.44E+13 |
| 0.05 | 0.02 | | | | | | | | |
| 0.05 | 0.02 | } 2.92E+12 | | | } 1.04E+15 | } 2.04E+14 | } 2.07E+14 | } 2.07E+14 | } 1.11E+13 |
| 0.02 | 0.01 | | | | | | | | |
| 0.02 | 0.01 | } 1.16E+09 | | | } 1.04E+15 | } 2.04E+14 | } 2.07E+14 | } 2.07E+14 | } 1.67E+13 |
| 0.01 | 0.00 | | | | | | | | |
| TOTAL SOURCE | | 5.34E+15 | 4.33E+15 | 4.61E+15 | 5.94E+15 | 5.92E+15 | 4.27E+15 | 5.79E+15 | 6.42E+15 |

*Results for average burn-up x relative local burn-up

94750026

Table 11. Gamma Benchmark. Gamma-ray source spectrum.

Assembly 5 Top of the active fuel (burn up=2966 MWdays/tonne)

| Group boundaries | | Gamma-ray source (MeV/s/tonne) | | | | | | | |
|------------------|---------------|--------------------------------|------------|-------------|------------|------------|------------|------------|------------|
| Emax. (MeV) | Emin (MeV) | UK(AEA) | UK(BNFL) | Netherlands | Germany | Italy | France | USA | Belgium* |
| 4.00 | 3.50 | } 1.95E+10 | } 1.10E+10 | } 2.56E+10 | } 2.47E+10 | } 2.37E+10 | } 3.79E+11 | } 3.00E+10 | } 2.70E+11 |
| 3.50 | 3.00 | | | | | | | | |
| 3.00 | 2.50 | } 1.06E+11 | } 4.90E+10 | } 2.10E+11 | } 1.40E+11 | } 1.64E+11 | } 1.67E+13 | } 2.04E+11 | } 1.68E+13 |
| 2.50 | 2.20 | | | | | | | | |
| 2.20 | 2.00 | } 1.53E+13 | } 1.50E+13 | } 1.55E+13 | } 2.58E+11 | } 1.76E+13 | } 1.67E+13 | } 2.05E+13 | } 4.40E+12 |
| 2.00 | 1.80 | | | | | | | | |
| 1.80 | 1.66 | } 5.44E+11 | } 5.10E+11 | } 9.76E+11 | } 1.66E+13 | } 2.07E+12 | } 1.67E+13 | } 2.49E+12 | } 1.22E+14 |
| 1.66 | 1.50 | | | | | | | | |
| 1.50 | 1.44 | } 4.80E+12 | } 4.10E+12 | } 1.99E+12 | } 1.10E+13 | } 9.79E+12 | } 2.93E+13 | } 1.19E+13 | } 1.22E+14 |
| 1.44 | 1.33 | | | | | | | | |
| 1.33 | 1.22 | } 3.75E+12 | } 2.20E+12 | } 5.64E+13 | } 1.64E+13 | } 1.64E+13 | } 2.93E+13 | } 2.02E+13 | } 1.81E+14 |
| 1.22 | 1.00 | | | | | | | | |
| 1.00 | 0.80 | } 7.61E+12 | } 7.20E+12 | } 6.73E+13 | } 1.84E+13 | } 2.26E+13 | } 1.69E+14 | } 2.96E+13 | } 4.77E+14 |
| 0.80 | 0.70 | | | | | | | | |
| 0.70 | 0.60 | } 5.14E+12 | } 3.40E+12 | } 2.01E+13 | } 1.12E+14 | } 2.61E+14 | } 4.42E+14 | } 3.12E+14 | } 9.90E+12 |
| 0.60 | 0.51 | | | | | | | | |
| 0.51 | 0.40 | } 2.82E+14 | } 2.60E+14 | } 3.42E+14 | } 8.05E+13 | } 6.33E+13 | } 4.42E+14 | } 7.99E+13 | } 5.20E+12 |
| 0.40 | 0.30 | | | | | | | | |
| 0.30 | 0.20 | } 3.71E+13 | } 3.20E+13 | } 5.24E+12 | } 1.43E+14 | } 1.96E+13 | } 1.80E+13 | } 2.31E+13 | } 9.90E+12 |
| 0.20 | 0.10 | | | | | | | | |
| 0.10 | 0.05 | } 1.27E+11 | } 9.70E+10 | } 1.73E+11 | } 1.43E+14 | } 1.80E+13 | } 4.52E+13 | } 2.11E+13 | } 1.61E+13 |
| 0.05 | 0.02 | | | | | | | | |
| 0.02 | 0.01 | } 8.18E+10 | } 5.10E+10 | } 1.47E+13 | } 1.47E+13 | } 4.52E+13 | } 2.32E+13 | } 5.31E+13 | } 1.90E+12 |
| 0.01 | 0.00 | | | | | | | | |
| 0.01 | 0.00 | } 1.25E+12 | } 1.48E+13 | } 1.25E+12 | } 3.80E+11 | } 2.32E+13 | } 2.85E+13 | } 2.73E+13 | } 1.50E+12 |
| 0.02 | 0.01 | | | | | | | | |
| 0.01 | 0.00 | } 3.80E+11 | } 1.02E+08 | } 1.02E+08 | } 1.02E+08 | } 2.85E+13 | } 2.85E+13 | } 3.44E+13 | } 2.20E+12 |
| 0.02 | 0.01 | | | | | | | | |
| 0.01 | 0.00 | } 5.40E+09 | } 5.40E+09 | } 5.40E+09 | } 5.40E+09 | } 5.40E+09 | } 5.40E+09 | } 5.40E+09 | } 5.40E+09 |
| 0.01 | 0.00 | | | | | | | | |
| TOTAL SOURCE | | 3.73E+14 | 3.39E+14 | 7.02E+14 | 5.29E+14 | 5.27E+14 | 6.57E+14 | 6.36E+14 | 8.38E+14 |

*Results for average burn-up x relative local burn-up

9/17/02 10:27

Table 12. Gamma Benchmark. Gamma-ray source spectrum.

Assembly 12 Mid height of the active fuel (burn up=27723 MWdays/tonne)

| Group boundaries | | Gamma-ray source (MeV/s/tonne) | | | | | | | |
|---------------------------|---------------------------|--------------------------------|------------|-------------|------------|------------|------------|------------|------------|
| E _{max} (MeV) | E _{min} (MeV) | UK(AEA) | UK(BNFL) | Netherlands | Germany | Italy | France | USA | Belgium* |
| 4.00 | 3.50 | } 6.99E+11 | } 4.40E+11 | } 4.34E+11 | } 4.80E+08 | } 8.69E+11 | } 7.12E+12 | } 8.72E+11 | } 4.50E+12 |
| 3.50 | 3.00 | | | | | | | | |
| 3.00 | 2.50 | } 2.60E+14 | } 2.60E+14 | } 2.75E+14 | } 5.36E+12 | } 2.92E+14 | } 2.92E+14 | } 2.93E+14 | } 7.50E+13 |
| 2.50 | 2.20 | | | | | | | | |
| 2.20 | 2.00 | } 1.75E+13 | } 1.80E+13 | } 1.62E+13 | } 2.76E+14 | } 5.40E+13 | } 2.92E+14 | } 5.46E+13 | } 7.50E+13 |
| 2.00 | 1.80 | | | | | | | | |
| 1.80 | 1.66 | } 1.15E+14 | } 1.10E+14 | } 3.56E+13 | } 3.86E+14 | } 3.43E+14 | } 4.85E+14 | } 3.29E+14 | } 1.42E+15 |
| 1.66 | 1.50 | | | | | | | | |
| 1.50 | 1.44 | } 3.48E+14 | } 2.70E+14 | } 6.19E+14 | } 7.51E+14 | } 7.03E+14 | } 5.09E+15 | } 6.46E+14 | } 5.08E+15 |
| 1.44 | 1.33 | | | | | | | | |
| 1.33 | 1.22 | } 3.95E+14 | } 3.80E+14 | } 8.19E+14 | } 4.25E+15 | } 1.57E+15 | } 5.09E+15 | } 1.52E+15 | } 6.35E+15 |
| 1.22 | 1.00 | | | | | | | | |
| 1.00 | 0.80 | } 4.65E+14 | } 3.60E+14 | } 3.47E+14 | } 4.35E+15 | } 1.21E+16 | } 7.36E+15 | } 7.39E+15 | } 6.35E+15 |
| 0.80 | 0.70 | | | | | | | | |
| 0.70 | 0.60 | } 1.08E+16 | } 9.00E+15 | } 4.35E+15 | } 1.36E+15 | } 7.36E+15 | } 6.72E+15 | } 2.84E+15 | } 6.35E+15 |
| 0.60 | 0.51 | | | | | | | | |
| 0.51 | 0.40 | } 1.71E+15 | } 1.50E+15 | } 9.31E+13 | } 9.31E+13 | } 2.86E+15 | } 2.86E+15 | } 2.84E+15 | } 1.32E+14 |
| 0.40 | 0.30 | | | | | | | | |
| 0.40 | 0.30 | } 2.76E+12 | } 2.10E+12 | } 2.14E+12 | } 2.64E+15 | } 3.72E+14 | } 3.72E+14 | } 3.73E+14 | } 8.13E+13 |
| 0.30 | 0.20 | | | | | | | | |
| 0.30 | 0.20 | } 6.74E+12 | } 4.90E+12 | } 2.14E+12 | } 2.64E+15 | } 3.43E+14 | } 3.43E+14 | } 3.42E+14 | } 8.13E+13 |
| 0.20 | 0.10 | | | | | | | | |
| 0.20 | 0.10 | } 2.55E+14 | } 2.60E+14 | } 2.14E+12 | } 2.64E+15 | } 8.13E+14 | } 8.13E+14 | } 8.14E+14 | } 2.76E+13 |
| 0.10 | 0.05 | | | | | | | | |
| 0.10 | 0.05 | } 2.21E+13 | } 2.60E+14 | } 2.14E+12 | } 2.64E+15 | } 4.17E+14 | } 4.17E+14 | } 4.21E+14 | } 2.99E+13 |
| 0.05 | 0.02 | | | | | | | | |
| 0.05 | 0.02 | } 6.77E+12 | } 2.60E+14 | } 2.14E+12 | } 2.64E+15 | } 5.02E+14 | } 5.02E+14 | } 5.17E+14 | } 2.05E+13 |
| 0.02 | 0.01 | | | | | | | | |
| 0.02 | 0.01 | } 2.23E+09 | } 2.60E+14 | } 2.14E+12 | } 2.64E+15 | } 5.02E+14 | } 5.02E+14 | } 5.17E+14 | } 2.05E+13 |
| 0.01 | 0.00 | | | | | | | | |
| 0.01 | 0.00 | } 1.19E+11 | } 2.60E+14 | } 2.14E+12 | } 2.64E+15 | } 5.02E+14 | } 5.02E+14 | } 5.17E+14 | } 3.62E+13 |
| 0.01 | 0.00 | | | | | | | | |
| TOTAL SOURCE | | 1.44E+16 | 1.22E+16 | 1.22E+16 | 1.62E+16 | 1.56E+16 | 1.26E+16 | 1.55E+16 | 1.36E+16 |

*Results for average burn-up x relative local burn-up

94750028

Table 13. Gamma Benchmark. Gamma-ray source spectrum.

Assembly 12 Top of the active fuel (burn up=10959 MWdays/tonne)

| Group boundaries | | Gamma-ray source (MeV/s/tonne) | | | | | | | |
|---------------------------|---------------------------|--------------------------------|------------|-------------|------------|------------|--------|------------|------------|
| E _{max} (MeV) | E _{min} (MeV) | UK(AEA) | UK(BNFL) | Netherlands | Germany | Italy | France | USA | Belgium* |
| 4.00 | 3.50 | } 1.78E+11 | } 1.10E+11 | } 1.72E+11 | } 2.45E+11 | } 2.30E+11 | } | } 2.38E+11 | } 1.30E+12 |
| 3.50 | 3.00 | | | | | | | | |
| 3.00 | 2.50 | } 9.55E+11 | } 7.30E+11 | } 1.41E+12 | } 1.91E+12 | } 1.21E+14 | } | } 1.26E+14 | } |
| 2.50 | 2.20 | | | | | | | | |
| 2.20 | 2.00 | } 1.07E+14 | } 1.10E+14 | } 1.09E+14 | } 1.14E+14 | } | } | } 1.76E+13 | } |
| 2.00 | 1.80 | | | | | | | | |
| 1.80 | 1.66 | } 4.53E+12 | } 4.40E+12 | } 6.39E+12 | } 9.87E+13 | } | } | } 8.96E+13 | } |
| 1.66 | 1.50 | | | | | | | | |
| 1.50 | 1.44 | } 3.69E+13 | } 3.70E+13 | } 2.45E+14 | } | } 8.76E+13 | } | } 8.96E+13 | } |
| 1.44 | 1.33 | | | | | | | | |
| 1.33 | 1.22 | } 5.58E+13 | } 3.70E+13 | } 3.24E+14 | } 1.77E+14 | } 1.61E+14 | } | } 1.61E+14 | } |
| 1.22 | 1.00 | | | | | | | | |
| 1.00 | 0.80 | } 8.27E+13 | } 7.80E+13 | } 1.37E+14 | } | } 2.90E+14 | } | } 2.99E+14 | } |
| 0.80 | 0.70 | | | | | | | | |
| 0.70 | 0.60 | } 7.54E+13 | } 5.30E+13 | } 1.68E+15 | } 3.42E+15 | } 2.38E+15 | } | } 2.50E+15 | } |
| 0.60 | 0.51 | | | | | | | | |
| 0.51 | 0.40 | } 2.94E+15 | } 2.60E+15 | } 1.72E+15 | } | } 6.83E+14 | } | } 6.83E+14 | } |
| 0.40 | 0.30 | | | | | | | | |
| 0.30 | 0.20 | } 3.82E+14 | } 3.30E+14 | } 5.39E+14 | } 9.75E+14 | } 6.56E+14 | } | } 1.41E+14 | } |
| 0.20 | 0.10 | | | | | | | | |
| 0.10 | 0.05 | } 3.82E+14 | } 3.30E+14 | } 3.68E+13 | } | } 1.36E+14 | } | } 1.29E+14 | } |
| 0.05 | 0.02 | | | | | | | | |
| 0.02 | 0.01 | } 7.88E+11 | } 5.80E+11 | } 8.45E+11 | } | } 5.76E+13 | } | } 3.21E+14 | } |
| 0.01 | 0.00 | | | | | | | | |
| | | } 1.38E+12 | } 7.30E+11 | } | } | } 3.09E+14 | } | } 1.62E+14 | } |
| | | | | | | | | | |
| | | } 1.03E+14 | } 1.00E+14 | } | } | } 1.56E+14 | } | } 2.01E+14 | } |
| | | | | | | | | | |
| | | } 8.01E+12 | } | } | } | } 1.89E+14 | } | } | } |
| | | | | | | | | | |
| | | } 2.36E+12 | } | } | } | } | } | } | } |
| | | | | | | | | | |
| | | } 4.83E+08 | } | } | } | } | } | } | } |
| | | | | | | | | | |
| | | } 2.57E+10 | } | } | } | } | } | } | } |
| | | | | | | | | | |
| TOTAL SOURCE | | 3.80E+15 | 3.35E+15 | 4.81E+15 | 4.79E+15 | 4.56E+15 | | 4.83E+15 | 3.88E+15 |

*Results for average burn-up x relative local burn-up

98770029

Table 14. Neutron Benchmark. Neutron source strength.

| | Spontaneous Neutron Source | | | | Neutrons from (alpha,n) reactions | | | |
|-----------------|------------------------------|-----------------------|------------------------------|-----------------------|-----------------------------------|-----------------------|------------------------------|-----------------------|
| | Assembly 5 | | Assembly 12 | | Assembly 5 | | Assembly 12 | |
| | Neutrons/s/tonne U | | Neutrons/s/tonne U | | Neutrons/s/tonne U | | Neutrons/s/tonne U | |
| | Mid height of active fuel | Top of active fuel | Mid height of active fuel | Top of active fuel | Mid height of active fuel | Top of active fuel | Mid height of active fuel | Top of active fuel |
| [burn up MWd/t] | [38780] | [14862] | [38893] | [14930] | [38780] | [14862] | [38893] | [14930] |
| UK (AEA) | | | 6.17E+08 | 9.49E+06 | | | 1.37E+07 | 1.42E+06 |
| UK(BNFL) | 4.82E+08* | 8.54E+06 | 4.82E+08* | 8.54E+06 | 1.16E+07* | 1.30E+06 | 1.16E+07* | 1.30E+06 |
| FRG | 7.01E+08 | 1.28E+07 | 7.09E+08 | 1.30E+07 | 3.40E+07 | 3.70E+06 | 3.42E+07 | 3.73E+06 |
| Italy | 6.35E+08 | 1.09E+07 | 6.42E+08 | 1.11E+07 | 1.53E+07 | 1.65E+06 | 1.54E+07 | 1.66E+06 |
| France(Apollo) | 7.47E+08 | 1.12E+07 | 7.56E+08 | 1.15E+07 | 1.58E+07 | 1.37E+06 | 1.59E+07 | 1.38E+06 |
| USA | 7.55E+08 | 2.81E+07 | | | 1.58E+07 | 2.62E+06 | | |
| Belgium | 7.34E+08 | 8.58E+06 | 7.38E+08 | 8.73E+06 | 1.67E+07 | 1.50E+06 | 1.68E+07 | 1.51E+06 |

*These results are for 19.25 - 340.09cm of active fuel region and are not directly comparable with the mid-height values.

94750030

Table 15. Neutron Benchmark. Actinide Concentrations.

Mid height of the active fuel (burn up = 38893 MWdays/tonne)

| Actinide | Actinide concentration (nuclei/tonne) | | | | | |
|----------|---------------------------------------|-----------|----------|----------|----------|----------|
| | UK (AEA) | UK(BNFL)* | Germany | Italy | USA | Belgium |
| Pu 238 | 5.04E+23 | 4.75E+23 | 5.55E+23 | 6.24E+23 | 6.35E+23 | 5.80E+23 |
| Pu 240 | 6.66E+24 | 6.66E+24 | 7.10E+24 | 6.14E+24 | 6.08E+24 | 6.45E+24 |
| Pu 242 | 1.96E+24 | 1.56E+24 | 1.91E+24 | 1.69E+24 | 1.85E+24 | 1.79E+24 |
| Am 241 | 4.06E+23 | 4.20E+23 | 4.29E+23 | 4.99E+23 | 4.57E+23 | 4.00E+23 |
| Cm 242 | 3.49E+21 | 2.84E+21 | 3.38E+21 | 3.49E+21 | 3.18E+21 | 3.30E+21 |
| Cm 244 | 1.32E+23 | 1.03E+23 | 1.44E+23 | 1.34E+23 | 1.59E+23 | 1.56E+23 |
| Cm 246 | 9.59E+20 | 6.59E+20 | 1.18E+21 | 9.97E+20 | 1.29E+21 | - |
| Cf 252 | 2.79E+14 | 1.56E+14 | 5.85E+14 | | - | - |

*19.3 - 340.1 cm of active fuel region

Top of the active fuel (burn up = 14930 MWdays/tonne)

| Actinide | Actinide concentration (nuclei/tonne) | | | | | |
|----------|---------------------------------------|----------|----------|----------|----------|----------|
| | UK (AEA) | UK(BNFL) | Germany | Italy | USA | Belgium |
| Pu 238 | 5.38E+22 | 5.25E+22 | 5.95E+22 | 6.90E+22 | 1.16E+23 | 5.35E+22 |
| Pu 240 | 2.53E+24 | 2.55E+24 | 2.76E+24 | 2.50E+24 | 3.18E+24 | 2.53E+24 |
| Pu 242 | 1.71E+23 | 1.48E+23 | 1.92E+23 | 1.68E+23 | 3.22E+23 | 1.53E+23 |
| Am 241 | 1.35E+23 | 1.32E+23 | 1.44E+23 | 1.60E+23 | 2.20E+23 | 1.29E+23 |
| Cm 242 | 3.89E+20 | 3.12E+20 | 4.18E+20 | 3.88E+20 | 6.63E+20 | 3.35E+20 |
| Cm 244 | 1.13E+21 | 1.06E+21 | 1.73E+21 | 1.47E+21 | 4.65E+21 | |
| Cm 246 | 1.03E+18 | 6.59E+20 | 1.79E+18 | 1.42E+18 | 7.42E+18 | |
| Cf 252 | 6.06E+08 | 7.47E+11 | 3.53E+09 | | | |

Table 17. Neutron spectra for the alpha,n source

| France | | US/Italy | | Belgium | |
|--------------------|------------------------|--------------------|------------------------|-------------------|------------------------|
| Lower Energy (MeV) | Fraction of n in group | Lower Energy (MeV) | Fraction of n in group | Mean Energy (MeV) | Fraction of n in group |
| 1.49E+01 | | 2.00E+01 | | | |
| 1.35E+01 | | | | | |
| 1.22E+01 | | | | | |
| 1.11E+01 | | | | | |
| 1.00E+01 | | | | | |
| 9.05E+00 | | | | | |
| 8.19E+00 | | | | | |
| 7.41E+00 | | | | | |
| 6.70E+00 | | 6.43E+00 | 0.00E+00 | | |
| 6.07E+00 | | | | | |
| 5.49E+00 | | | | | |
| 4.97E+00 | | | | | |
| 4.49E+00 | 1.99E-03 | | | 4.58E+00 | 1.00E+00 |
| 4.07E+00 | 1.92E-02 | | | | |
| 3.68E+00 | 4.57E-02 | | | | |
| 3.33E+00 | 8.56E-02 | | | | |
| 3.01E+00 | 1.33E-01 | 3.00E+00 | 3.10E-01 | | |
| 2.73E+00 | 1.29E-01 | | | | |
| 2.47E+00 | 1.19E-01 | | | | |
| 2.23E+00 | 1.04E-01 | | | | |
| 2.02E+00 | 8.78E-02 | | | | |
| 1.83E+00 | 7.24E-02 | 1.85E+00 | 5.10E-01 | | |
| 1.65E+00 | 4.79E-02 | | | | |
| 1.50E+00 | 4.02E-02 | | | | |
| 1.35E+00 | 3.40E-02 | 1.40E+00 | 1.09E-01 | | |
| 1.22E+00 | 2.93E-02 | | | | |
| 1.11E+00 | 2.65E-02 | | | | |
| 1.00E+00 | 2.52E-02 | | | | |
| 9.07E-01 | | 9.00E-01 | 5.40E-02 | | |
| 8.21E-01 | | | | | |
| 7.43E-01 | | | | | |
| 6.72E-01 | | | | | |
| 6.08E-01 | | | | | |
| 5.50E-01 | | | | | |
| 4.98E-01 | | | | | |
| 4.50E-01 | | | | | |
| 4.08E-01 | | 4.00E-01 | 1.50E-02 | | |
| 3.69E-01 | | | | | |
| 3.34E-01 | | | | | |
| 3.02E-01 | | | | | |
| 2.73E-01 | | | | | |
| 2.47E-01 | | | | | |
| 2.24E-01 | | | | | |
| 2.02E-01 | | | | | |
| 1.83E-01 | | 1.00E-01 | 2.00E-03 | | |

UK(AEA) and UK(BNFL) used their fission spectra because the (α,n) source is only ~2% of the total source at mid-height.

Germany used

$$S(E) = \frac{(\ln 2/\pi)^{0.5}}{E} \times \exp -(E-E_m)^2 \times \frac{\ln 2}{E^2}$$

where $E_m = 2.5 + 2(E_\alpha - 5.9)$ MeV

Table 18. Gamma Benchmark. Co60 decay rates.

| | Assembly 5 | | | | Assembly 12 | | |
|--------------------|-------------------------------------|-----------------------------|------------------------|---------------------------|-----------------------------|------------------------|---------------------------|
| | Thermal Cross-section (barns) | Mixing grid (mid height) | Top nozzle (zone A) | Bottom nozzle (zone E) | Mixing grid (mid height) | Top nozzle (zone A) | Bottom nozzle (zone E) |
| | | decay rate (Bq) | decay rate (Bq) | decay rate (Bq) | decay rate (Bq) | decay rate (Bq) | decay rate (Bq) |
| UK(AEA) | 23.7 | 4.25E+12 | 3.56E+11 | 6.43E+11 | 5.35E+12 | 6.48E+11 | 1.17E+12 |
| UK(BNFL) | | 6.50E+12 | 3.40E+12 | 4.80E+12 | 1.30E+13 | 8.80E+12 | 1.20E+13 |
| Netherlands | 37.3 (A&E) 23.3(mix. grid) | 1.38E+13 | 6.34E+11 | 1.41E+12 | 1.95E+13 | 1.18E+12 | 2.63E+12 |
| Italy | 23.5 | 1.79E+13 | 2.82E+11 | 1.11E+12 | 3.24E+13 | 5.08E+11 | 2.01E+12 |
| France | | 7.13E+12 | 6.01E+12 | 9.00E+11 | 1.32E+13 | 1.11E+13 | 1.66E+12 |
| Belgium | | 2.61E+13 | 1.83E+11 | 2.85E+11 | 3.20E+13 | 3.41E+11 | 5.46E+11 |

94770034

Table 19. Neutron response function

| E_{max} | E_{min} | ANSI Conversion factor ($\mu\text{Sv/h}$)/(n/cm²s) | Diop calculated Response function ($\mu\text{Sv/h}$)/(n/cm²s) |
|------------------------|------------------------|---|--|
| 14.0 | 10.0 | 1.450 | 1.310 |
| 10.0 | 5.6 | 1.450 | 1.310 |
| 5.6 | 3.2 | 1.450 | 1.450 |
| 3.2 | 1.8 | 1.400 | 1.530 |
| 1.8 | 1.0 | 1.450 | 1.420 |
| 1.0 | 5.60E-01 | 1.200 | 1.190 |
| 5.60E-01 | 3.20E-01 | 0.800 | 0.990 |
| 3.20E-01 | 1.80E-01 | 0.580 | 0.770 |
| 1.80E-01 | 1.00E-01 | 0.360 | 0.600 |
| 1.00E-01 | 5.60E-02 | 0.250 | 0.480 |
| 5.60E-02 | 3.20E-02 | 0.140 | 0.460 |
| 3.20E-02 | 1.80E-02 | 0.100 | 0.430 |
| 1.80E-02 | 1.00E-02 | 0.065 | 0.390 |
| 1.00E-02 | 5.60E-03 | 0.055 | 0.380 |
| 5.60E-03 | 3.20E-03 | 0.042 | 0.380 |
| 3.20E-03 | 1.80E-03 | 0.041 | 0.340 |
| 1.80E-03 | 1.00E-03 | 0.041 | 0.340 |
| 1.00E-03 | 5.60E-04 | 0.040 | 0.330 |
| 5.60E-04 | 3.20E-04 | 0.040 | 0.320 |
| 3.20E-04 | 1.80E-04 | 0.040 | 0.310 |
| 1.80E-04 | 1.00E-04 | 0.040 | 0.290 |
| 1.00E-04 | 5.60E-05 | 0.040 | 0.270 |
| 5.60E-05 | 3.20E-05 | 0.040 | 0.270 |
| 3.20E-05 | 1.80E-05 | 0.039 | 0.260 |
| 1.80E-05 | 1.00E-05 | 0.039 | 0.230 |
| 1.00E-05 | 5.60E-06 | 0.038 | 0.220 |
| 5.60E-06 | 3.20E-06 | 0.038 | 0.200 |
| 3.20E-06 | 1.80E-06 | 0.038 | 0.190 |
| 1.80E-06 | 1.00E-06 | 0.038 | 0.150 |
| 1.00E-06 | 5.60E-07 | 0.037 | 0.150 |
| 5.60E-07 | 3.20E-07 | 0.037 | 0.130 |
| 3.20E-07 | 1.80E-07 | 0.036 | 0.130 |

Table 20. Gamma Benchmark. Gamma-ray dose-rates at the peaks.

| | | EXPERIMENT | | | CALCULATION | | | | | | | | | | | |
|----------------------------|--------------------|--------------------------------|-----------------------------------|-----------|-----------------------------------|-----------|------|-----------------------------------|-----------|------|-----------------------------------|-----------|------|-----------------------------------|-----------|-----|
| | | | | | UK(AEA) (MCBEND) | | | UK(BNFL) (RANKERN) | | | USA (SAS4) | | | USA (DORT) | | |
| | θ (deg.) | Distance from fin tips (cm) | Dose rate ($\mu\text{Sv/h}$) | z (cm) | Dose rate ($\mu\text{Sv/h}$) | z (cm) | C/M | Dose rate ($\mu\text{Sv/h}$) | z (cm) | C/M | Dose rate ($\mu\text{Sv/h}$) | z (cm) | C/M | Dose rate ($\mu\text{Sv/h}$) | z (cm) | C/M |
| Peak at bottom of flask | 135 | 7.0 | 150.0 | 118.0 | 128.0 | 102-122 | 0.85 | 124.0 | 110 | 0.83 | 85.5 | 118 | 0.57 | | | |
| | 153 | 7.0 | 162.0 | 118.0 | 168.7 | 102-122 | 1.04 | 136.6 | 110 | 0.84 | 115.7 | 118 | 0.71 | | | |
| | | 100.0 | 54.0 | 108.0 | 48.1 | 142-162 | 0.89 | 43.4 | 110 | 0.80 | 38.1 | 118 | 0.71 | | | |
| | 180 | 7.0 | 145.0 | 112.0 | 143.1 | 102-122 | 0.99 | 101.9 | 110 | 0.70 | 119.5 | 118 | 0.82 | | | |
| Peak at top of flask | 135 | 7.0 | 210.0 | 420.0 | 212.4 | 402-422 | 1.01 | 199.0 | 410 | 0.95 | 218.5 | 419.9 | 1.04 | | | |
| | | 200.0 | 39.0 | 402.0 | 35.9 | 402-422 | 0.92 | 42.8 | 410 | 1.10 | 37.6 | 419.9 | 0.96 | | | |
| | 153 | 7.0 | 248.0 | 416.0 | 233.9 | 402-422 | 0.94 | 242.0 | 410 | 0.98 | 441.5 | 419.9 | 1.78 | | | |
| | | 100.0 | 80.0 | 402.0 | 77.0 | 402-422 | 0.96 | 91.8 | 410 | 1.15 | 78.9 | 419.9 | 0.99 | | | |
| | | 200.0 | 42.0 | 405.0 | 53.7 | 402-422 | 1.28 | 46.2 | 410 | 1.10 | 38.3 | 419.9 | 0.91 | | | |
| | 180 | 7.0 | 210.0 | 417.0 | 190.7 | 402-422 | 0.91 | 195.0 | 410 | 0.93 | 180.0 | 419.9 | 0.86 | | | |
| | | 200.0 | 38.0 | 396.0 | 38.8 | 402-422 | 1.02 | 42.1 | 410 | 1.11 | 35.0 | 419.9 | 0.92 | | | |
| | | | | | | | | | | | | | | | | |

with fin
correction

| | | EXPERIMENT | | | CALCULATION | | | | | | | | | | | |
|----------------------------|--------------------|--------------------------------|-----------------------------------|-----------|-----------------------------------|-----------|------|-----------------------------------|-----------|------|-----------------------------------|-----------|------|-----------------------------------|-----------|------|
| | | | | | France (MERCURE) | | | Italy (MCNP) | | | Netherlands (MARMER) | | | Belgium (QAD-CG) | | |
| | θ (deg.) | Distance from fin tips (cm) | Dose rate ($\mu\text{Sv/h}$) | z (cm) | Dose rate ($\mu\text{Sv/h}$) | z (cm) | C/M | Dose rate ($\mu\text{Sv/h}$) | z (cm) | C/M | Dose rate ($\mu\text{Sv/h}$) | z (cm) | C/M | Dose rate ($\mu\text{Sv/h}$) | z (cm) | C/M |
| Peak at bottom of flask | 135 | 7.0 | 150.0 | 118.0 | | | | 153.8 | | 1.03 | 136.4 | 118.0 | 0.91 | | | |
| | 153 | 7.0 | 162.0 | 118.0 | 190.0 | 114.0 | 1.17 | 161.7 | | 1.00 | 164.3 | 118.0 | 1.01 | 132.0 | 111.0 | 0.81 |
| | | 100.0 | 54.0 | 108.0 | 64.0 | 105.0 | 1.19 | 58.6 | | 1.09 | 59.1 | 108.0 | 1.09 | 43.0 | 111.0 | 0.80 |
| | 180 | 7.0 | 145.0 | 112.0 | | | | 173.3 | | 1.20 | 136.7 | 112.0 | 0.94 | | | |
| Peak at top of flask | 135 | 7.0 | 210.0 | 420.0 | | | | 192.9 | | 0.92 | 180.8 | 420.0 | 0.86 | | | |
| | | 200.0 | 39.0 | 402.0 | | | | 27.8 | | 0.71 | 39.7 | 402.0 | 1.02 | | | |
| | 153 | 7.0 | 248.0 | 416.0 | 237.0 | 417.0 | 0.96 | 228.6 | | 0.92 | 226.0 | 416.0 | 0.91 | 195.0 | 406.0 | 0.79 |
| | | 100.0 | 80.0 | 402.0 | 90.0 | 400.0 | 1.13 | 72 | | 0.90 | 80.9 | 402.0 | 1.01 | 78.0 | 406.0 | 0.98 |
| | | 200.0 | 42.0 | 405.0 | 46.5 | 407.0 | 1.11 | 32.2 | | 0.77 | 40.1 | 405.0 | 0.95 | 37.5 | 406.0 | 0.89 |
| | 180 | 7.0 | 210.0 | 417.0 | | | | 231.9 | | 1.10 | 172.1 | 417.0 | 0.82 | 172.0 | 406.0 | 0.82 |
| | | 200.0 | 38.0 | 396.0 | | | | 28 | | 0.74 | 39.9 | 396.0 | 1.05 | 38.0 | 406.0 | 1.00 |
| | | | | | | | | | | | | | | | | |

94750036

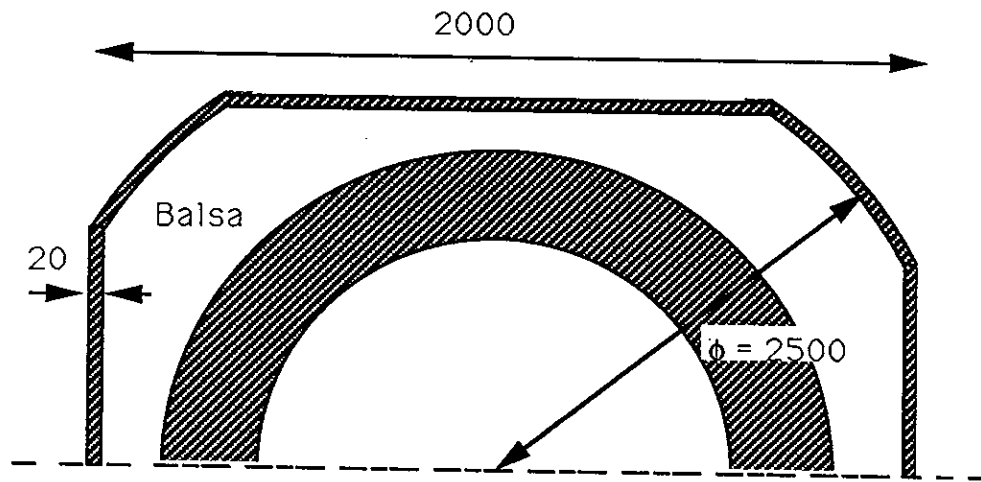
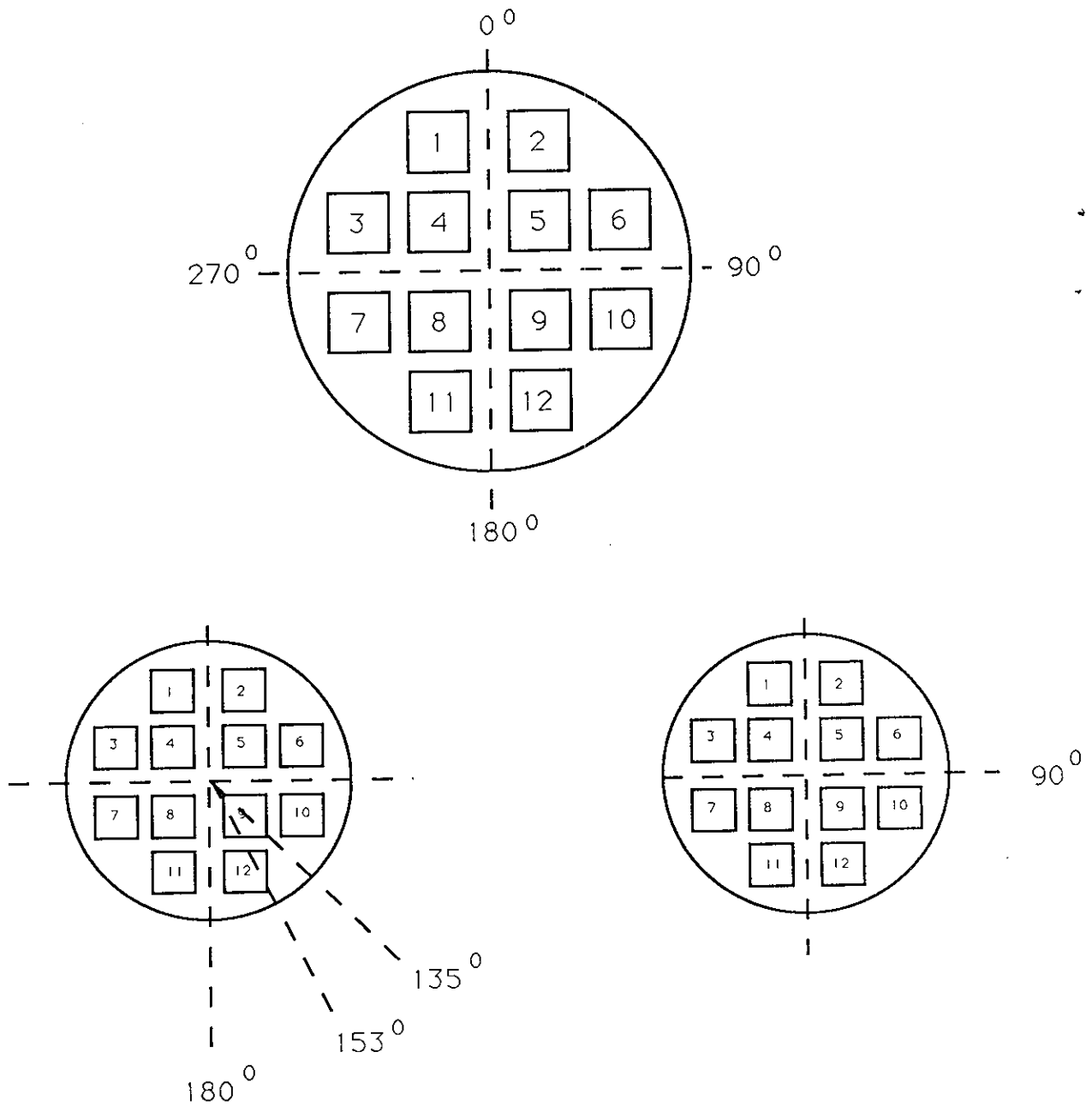

Figure 3. Cross-section showing shock absorbers at the ends of the container.



Gamma-ray scoring at 135°,
153° and 180°.

Neutron scoring at 90° only

Figure 4. Loading arrangement of the container

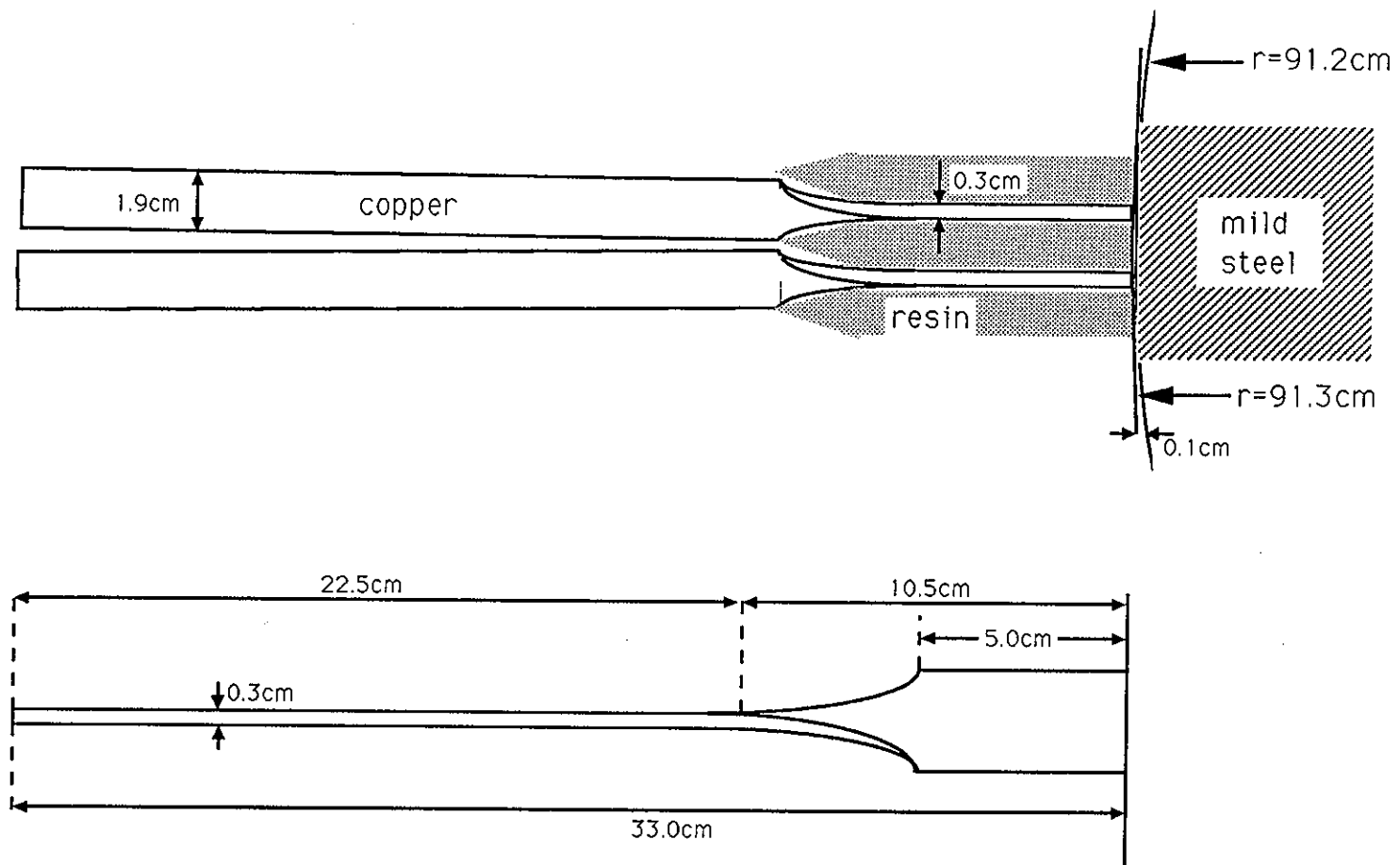
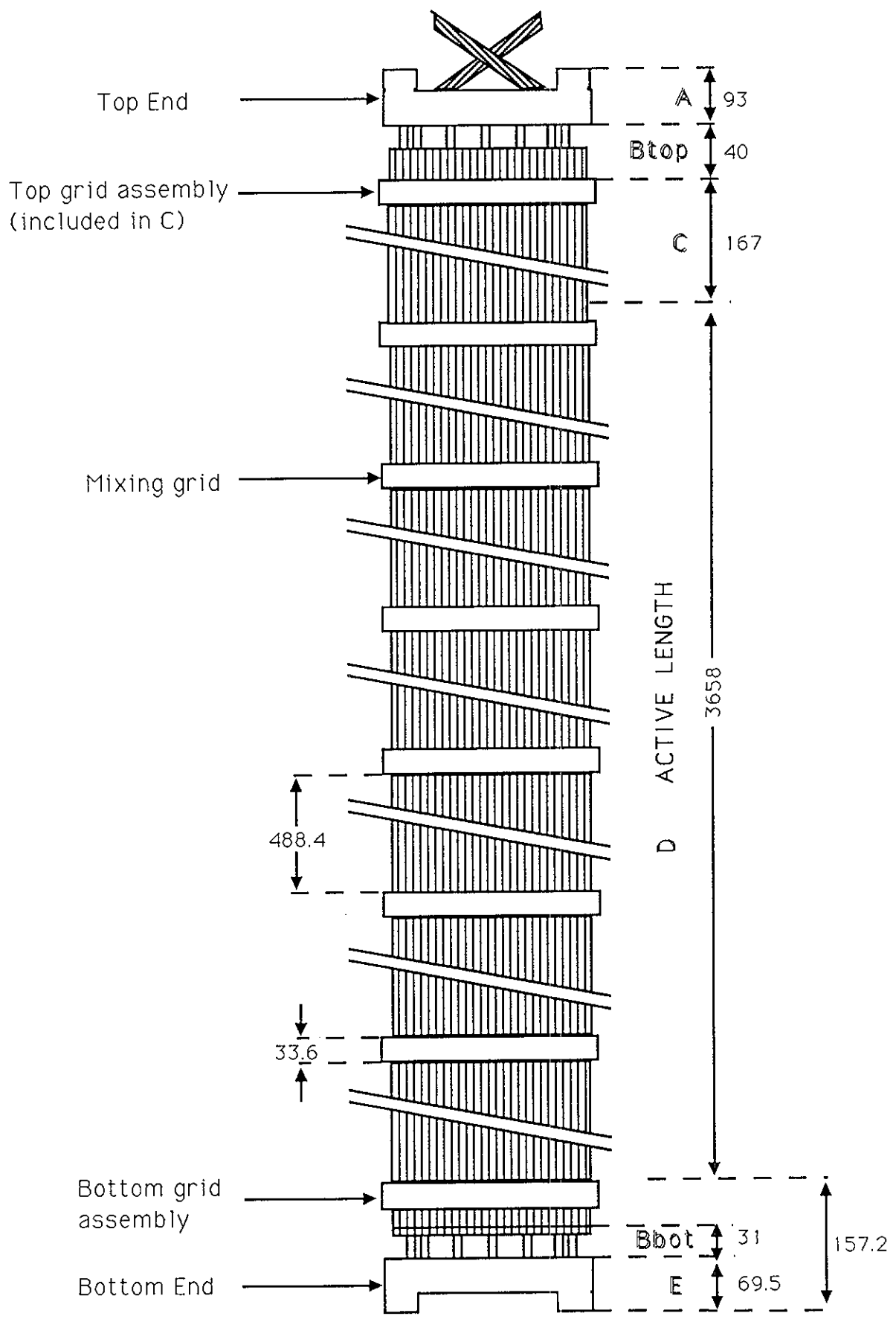

Figure 5. Diagram of fins on the TN12 container

94770040



all dimensions in mm.

Figure 6. Schematic representation of a fuel assembly

9250041

Figure 7. Power history for the gamma-ray benchmark

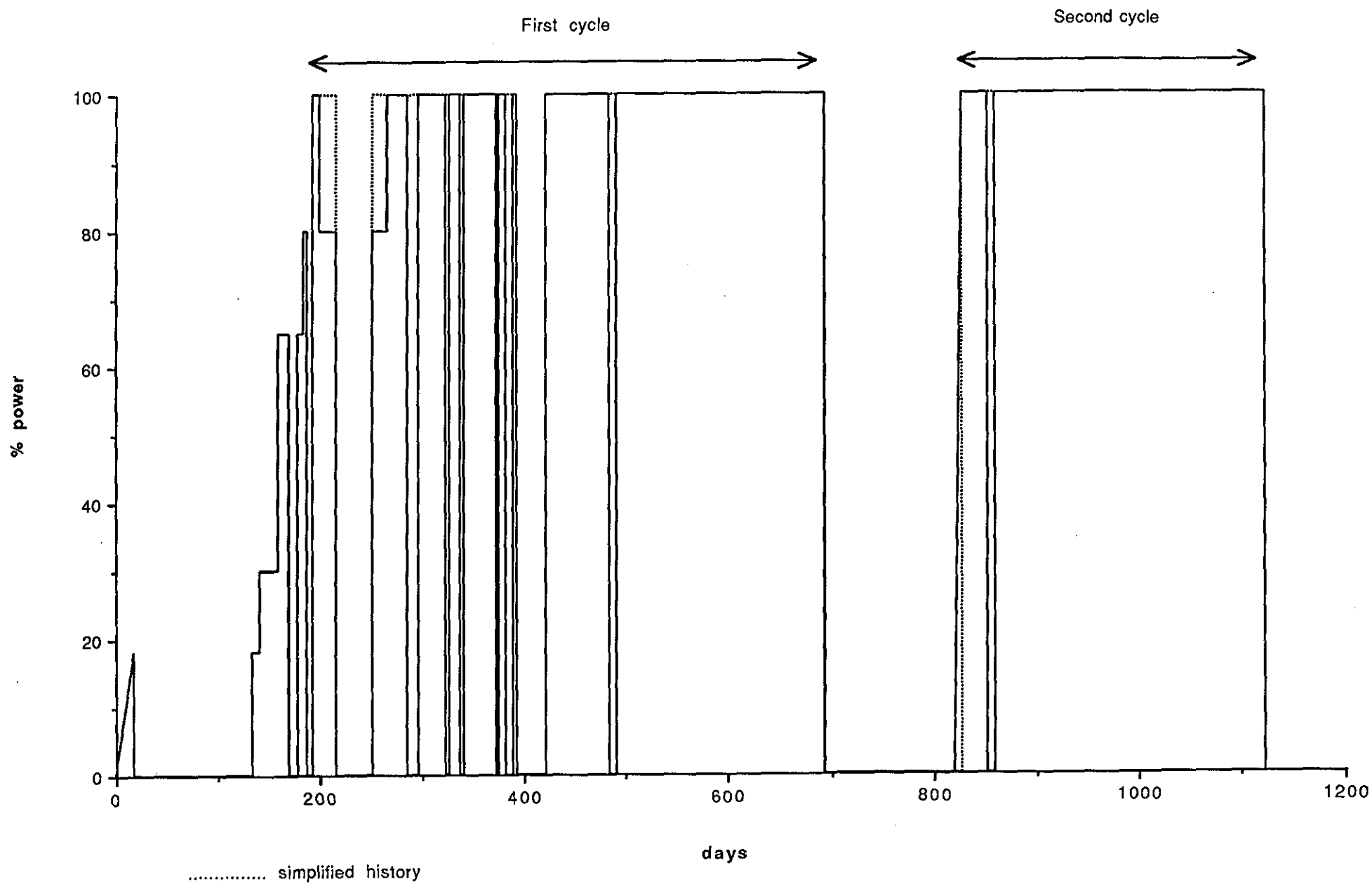

94750042

Figure 8. Thermal flux at the top of the fuel assembly

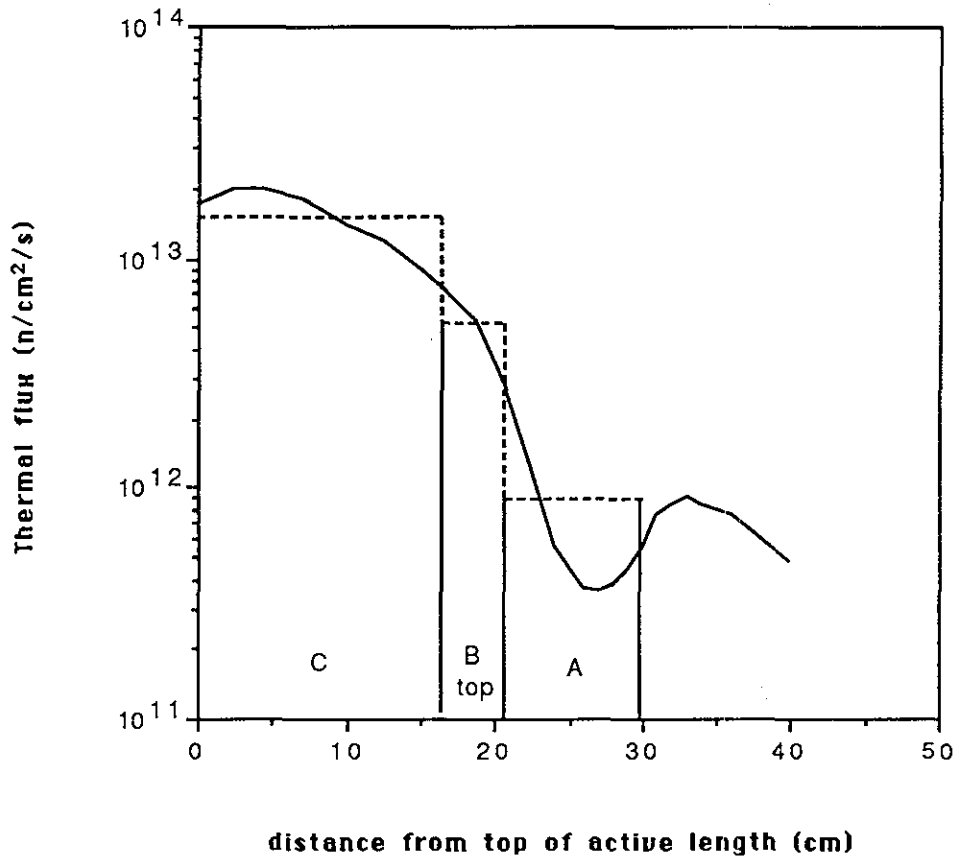
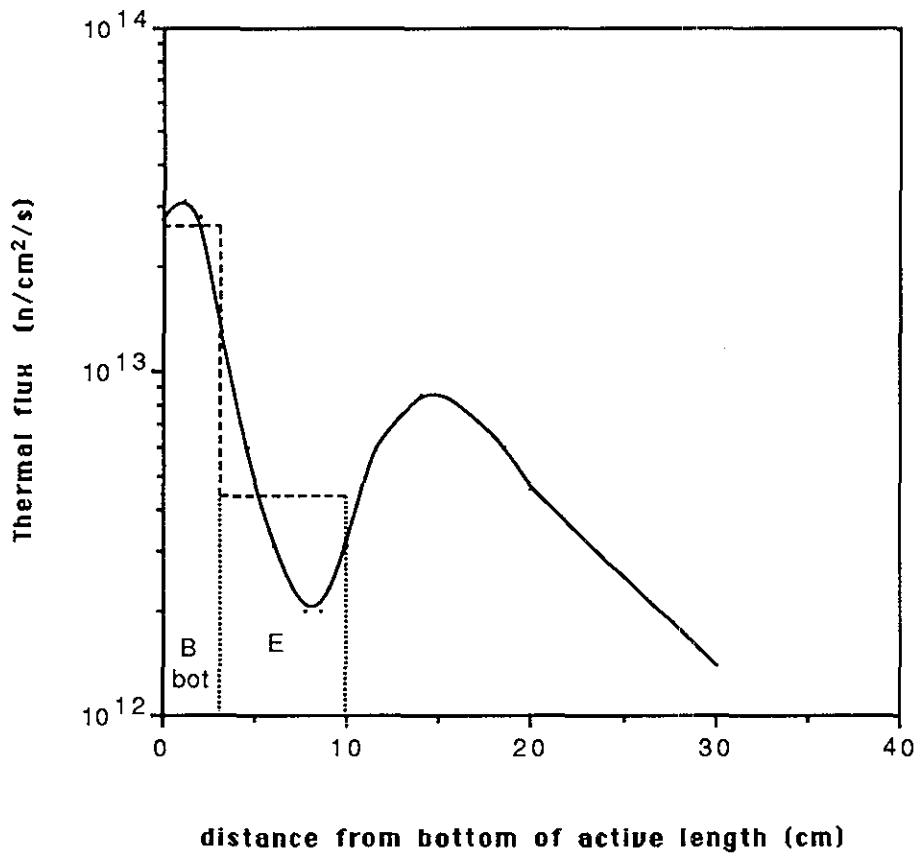

Figure 9. Thermal flux at the bottom of the fuel assembly.



9477043

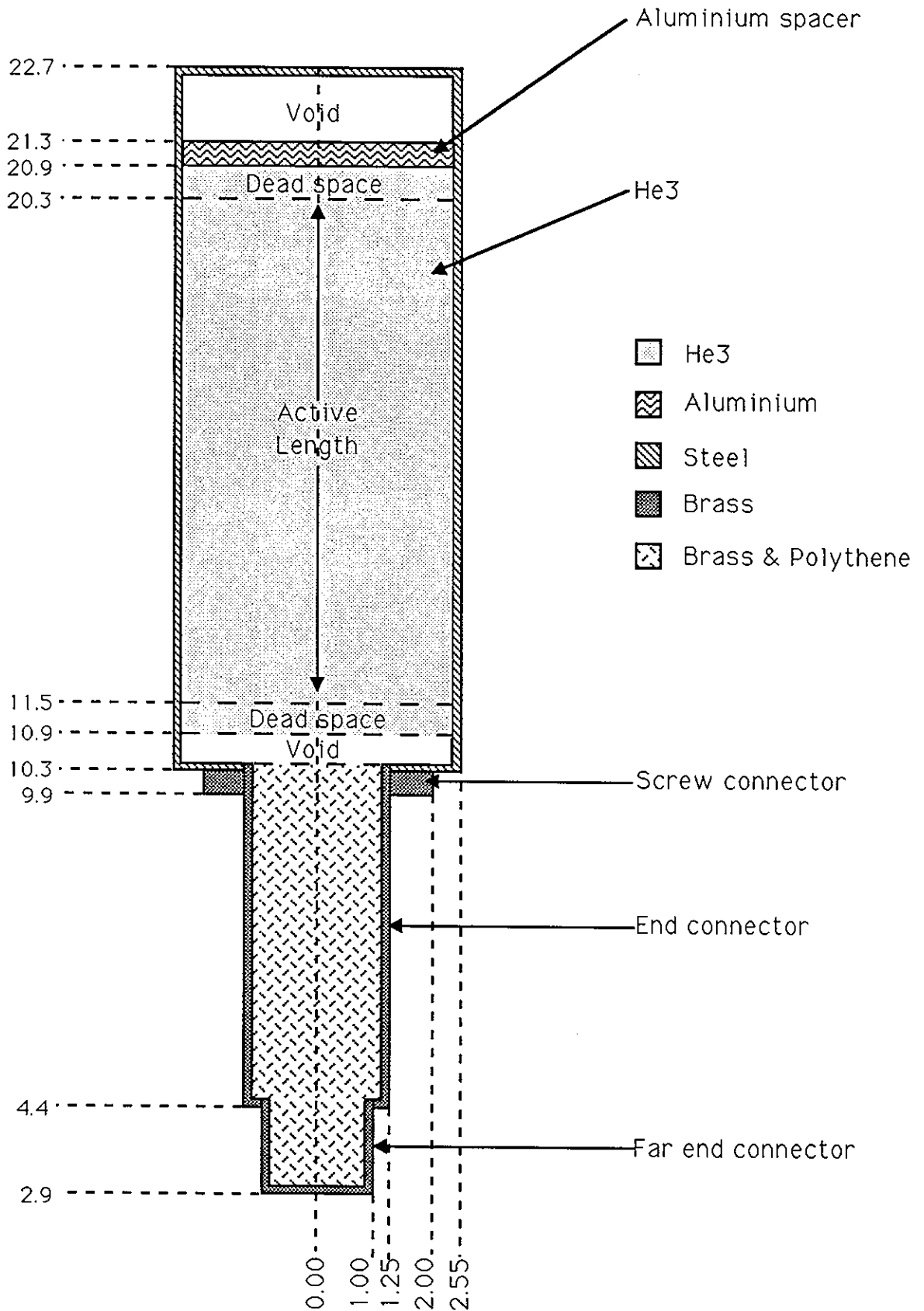

Figure 10. Simplified model of He3 detector

(Dimensions in cm. relative to outer casing of paraffin (see figure 11))

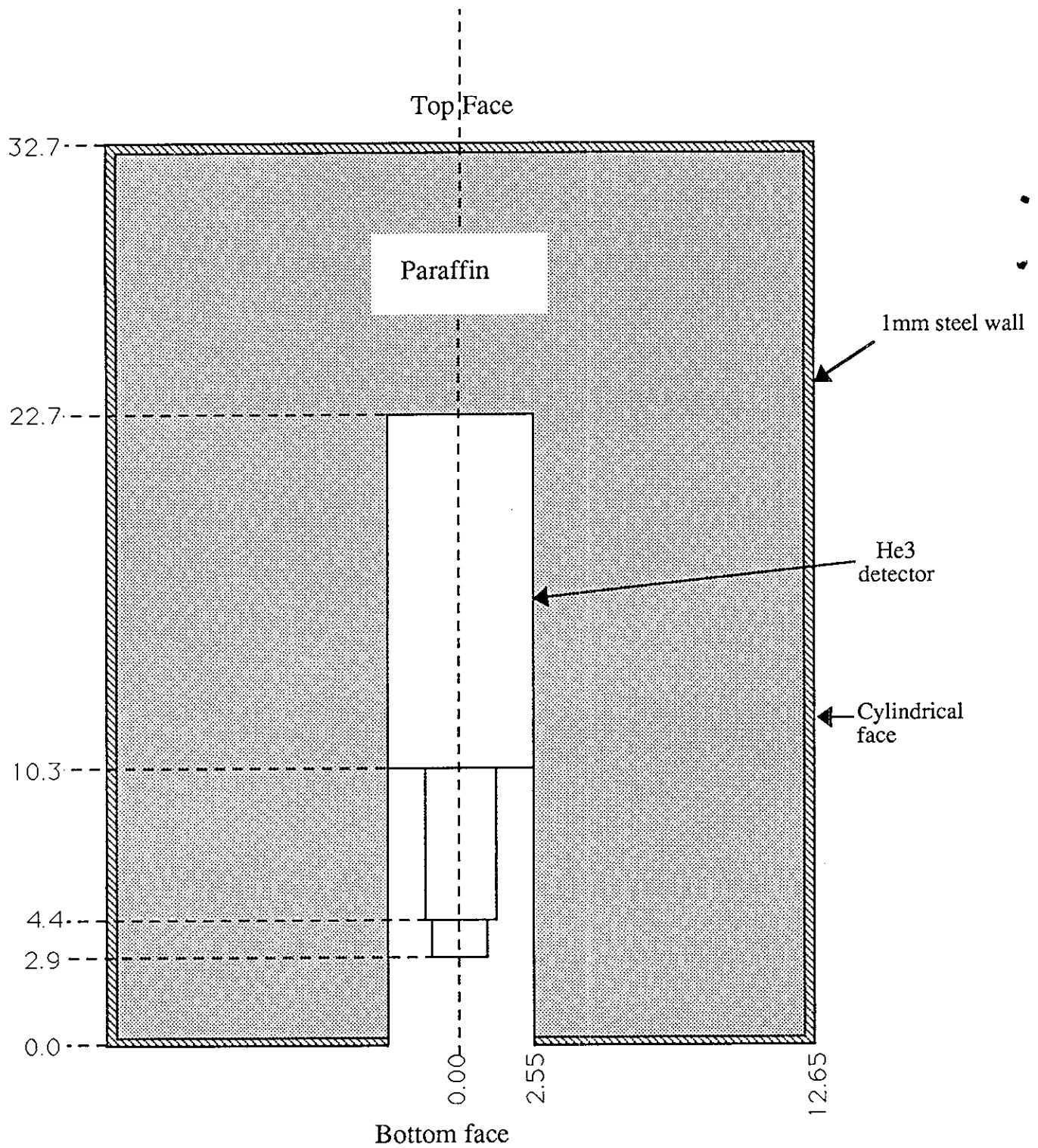

Figure 11. Simplified model of the dosimeter