

Nuclear Safety
NEA/CSNI/R(2009)8

ISBN 978-92-64-99110-1

Experimental Facilities for Gas-cooled Reactor Safety Studies

**Task Group on Advanced Reactor
Experimental Facilities (TAREF)**

© OECD 2009
NEA No. 6864

NUCLEAR ENERGY AGENCY
ORGANISATION FOR ECONOMIC CO-OPERATION AND DEVELOPMENT

ORGANISATION FOR ECONOMIC CO-OPERATION AND DEVELOPMENT

The OECD is a unique forum where the governments of 30 democracies work together to address the economic, social and environmental challenges of globalisation. The OECD is also at the forefront of efforts to understand and to help governments respond to new developments and concerns, such as corporate governance, the information economy and the challenges of an ageing population. The Organisation provides a setting where governments can compare policy experiences, seek answers to common problems, identify good practice and work to co-ordinate domestic and international policies.

The OECD member countries are: Australia, Austria, Belgium, Canada, the Czech Republic, Denmark, Finland, France, Germany, Greece, Hungary, Iceland, Ireland, Italy, Japan, Korea, Luxembourg, Mexico, the Netherlands, New Zealand, Norway, Poland, Portugal, the Slovak Republic, Spain, Sweden, Switzerland, Turkey, the United Kingdom and the United States. The Commission of the European Communities takes part in the work of the OECD.

OECD Publishing disseminates widely the results of the Organisation's statistics gathering and research on economic, social and environmental issues, as well as the conventions, guidelines and standards agreed by its members.

This work is published on the responsibility of the Secretary-General of the OECD. The opinions expressed and arguments employed herein do not necessarily reflect the official views of the Organisation or of the governments of its member countries.

NUCLEAR ENERGY AGENCY

The OECD Nuclear Energy Agency (NEA) was established on 1st February 1958 under the name of the OEEC European Nuclear Energy Agency. It received its present designation on 20th April 1972, when Japan became its first non-European full member. NEA membership today consists of 28 OECD member countries: Australia, Austria, Belgium, Canada, the Czech Republic, Denmark, Finland, France, Germany, Greece, Hungary, Iceland, Ireland, Italy, Japan, Luxembourg, Mexico, the Netherlands, Norway, Portugal, Republic of Korea, the Slovak Republic, Spain, Sweden, Switzerland, Turkey, the United Kingdom and the United States. The Commission of the European Communities also takes part in the work of the Agency.

The mission of the NEA is:

- to assist its member countries in maintaining and further developing, through international co-operation, the scientific, technological and legal bases required for a safe, environmentally friendly and economical use of nuclear energy for peaceful purposes, as well as
- to provide authoritative assessments and to forge common understandings on key issues, as input to government decisions on nuclear energy policy and to broader OECD policy analyses in areas such as energy and sustainable development.

Specific areas of competence of the NEA include safety and regulation of nuclear activities, radioactive waste management, radiological protection, nuclear science, economic and technical analyses of the nuclear fuel cycle, nuclear law and liability, and public information.

The NEA Data Bank provides nuclear data and computer program services for participating countries. In these and related tasks, the NEA works in close collaboration with the International Atomic Energy Agency in Vienna, with which it has a Co-operation Agreement, as well as with other international organisations in the nuclear field.

Corrigenda to OECD publications may be found on line at: www.oecd.org/publishing/corrigenda.

© OECD 2009

You can copy, download or print OECD content for your own use, and you can include excerpts from OECD publications, databases and multimedia products in your own documents, presentations, blogs, websites and teaching materials, provided that suitable acknowledgment of OECD as source and copyright owner is given. All requests for public or commercial use and translation rights should be submitted to rights@oecd.org. Requests for permission to photocopy portions of this material for public or commercial use shall be addressed directly to the Copyright Clearance Center (CCC) at info@copyright.com or the Centre français d'exploitation du droit de copie (CFC) contact@cfcopies.com.

Cover credits: High Temperature Engineering Test Reactor (HTTR), Japan Atomic Energy Agency, Japan and the High Flux Isotope Reactor, Oak Ridge National Laboratory, United States.

FOREWORD

In 2007, the NEA Committee on the Safety of Nuclear Installations (CSNI) completed a study on *Nuclear Safety Research in OECD Countries: Support Facilities for Existing and Advanced Reactors (SFEAR)* which focused on facilities suitable for current and advanced water reactor systems. In a subsequent collective opinion on the subject, the CSNI recommended to conduct a similar exercise for Generation IV reactor designs, aiming to develop a strategy for “better preparing the CSNI to play a role in the planned extension of safety research beyond the needs set by current operating reactors”.

In that context, the CSNI established the Task Group on Advanced Reactor Experimental Facilities (TAREF) in 2008 with the objective of providing an overview of facilities suitable for performing safety research relevant to gas-cooled reactors and sodium fast reactors. This report addresses gas-cooled reactors; a similar report covering sodium fast reactors is under preparation.

The findings of the TAREF are expected to trigger internationally funded CSNI projects on relevant safety issues at the key facilities identified. Such CSNI-sponsored projects constitute a means for efficiently obtaining the necessary data through internationally co-ordinated research.

TABLE OF CONTENTS

Foreword	3
Executive summary	7
1. Introduction	11
1.1 Background	11
1.2 Purpose	12
1.3 Scope	12
1.4 Approach	13
1.5 Co-ordination	14
1.6 Organisation of the report	14
2. Outline of reference gas-cooled reactors	15
2.1 Introduction	15
2.2 Outline of the HTR.....	15
2.3 Outline of the GFR.....	17
3. Technical areas, safety issues and facilities	21
3.1 Introduction	21
3.2 Description of technical areas and related safety issues.....	22
A.1 Accidents and thermal fluids.....	22
A.2 Description of safety issues in the accidents and thermal fluids area	24
B.1 Fission product transport.....	27
B.2 Description of safety issues in the fission product transport area	29
C.1 High-temperature metallic materials.....	30
C.2 Description of safety issues in the high-temperature metallic materials area	31
D.1 Graphite and ceramics.....	33
D.2 Description of safety issues in the graphite and ceramics area	34
E.1 Fuel	36
E.2 Description of safety issues in the fuel area.....	38
3.3 Facilities vs. issues	40
A. Accidents and thermal fluids.....	40
B. Fission product transport.....	43
C. High-temperature metallic materials.....	46
D. Graphite and ceramics.....	48
E. Fuel	49

4. Summary and recommendations	51
4.1 Summary	51
4.2 Conclusions and recommendations	52

References	54
-------------------------	----

Appendices

1. Description of experimental facilities for GCR safety studies.....	55
2. Terms of reference (TOR) of the TAREF Task Group.....	77
3. Quick summary of the TAREF meetings.....	79
4. List of TAREF members.....	87

EXECUTIVE SUMMARY

Background

The Task Group on Advanced Reactor Experimental Facilities (TAREF) was initiated based on discussions held by the OECD/NEA Committee on the Safety of Nuclear Installations (CSNI) and the Committee on Nuclear Regulatory Activities (CNRA) during a joint workshop on the Role of Research in a Regulatory Context (RRRC-2, June 2007). Among other topics, the workshop addressed the challenges that the nuclear community will face when performing safety evaluations of advanced reactor designs, the research that may be needed to perform the reviews, and the possible means for jointly conducting this research. In particular, the workshop discussed research topics relevant for gas-cooled reactors (GCRs) and sodium fast reactors (SFRs) and recommended that the CSNI organise a task group to identify the needed research and recommend a path forward.

CSNI initiated TAREF to provide an overview of facilities suitable for carrying out the safety research that was considered necessary for GCRs and SFRs. Other reactor systems could be considered in a subsequent phase.

The TAREF task was created in spring 2008, with the following Group of participating countries:

Canada	China	Czech Republic	Finland	France	Germany
Hungary	Italy	Japan	Korea	USA	

The Group decided to build on the experience of a similar activity conducted by CSNI and described in the report entitled *Nuclear Safety Research in OECD Countries: Support Facilities for Existing and Advanced Reactors (SFEAR)*, which focused on facilities suitable for current and advanced water reactor systems. In particular, the SFEAR method was adopted, consisting of first identifying high priority safety issues that require research, and then categorising the available facilities in terms of their ability to address the safety issues.

At the first TAREF meeting, it was decided that the GCR-related task could be completed at an earlier stage than the SFR task, considering that a significant part of the safety items to be addressed had already been compiled in an earlier USNRC exercise (called the Phenomenon Identification and Ranking Tables – PIRT) [5,10]. Hence, for practical reasons, it was decided to produce two separate Task reports, i.e. the present one on GCRs and a following one on SFRs – the latter being scheduled for the end of 2010.

The TAREF Group followed an approach similar to the PIRT performed by the USNRC, and consistent with that approach, identified the following technical areas to be addressed:

- A. Accident and thermal fluids (including neutronics);
- B. Fission-product transport;
- C. High-temperature metallic materials;
- D. Graphite and ceramics;
- E. Fuel (Tristructural-isotropic (TRISO) and other fuel types).

In the case of structural materials, graphite and ceramics experience can be broader than nuclear and this experience was considered to the degree possible. Other technical areas such as seismic assessment (except for potential consequences on core compaction), fire safety, instrumentation and control and human and organisational factors are not treated here, since the issues are not specific to GCRs.

For each of the above technical areas, the TAREF members identified the safety issues still needing research work. Only the issues identified as being of high safety relevance and for which the state of knowledge is low or medium were included in the discussions.

For each of the safety issues, the TAREF members identified the related facilities that were deemed appropriate to address the issue in question, providing relevant information such as operating conditions (in- or out-of-reactor), operating range, description of the test section, type of testing, instrumentation, current status and availability, uniqueness, etc.

Based on the information that was assembled on both safety issues and related facilities, the task members assessed prospects and priorities for GCR safety research and developed recommendations as to priorities and options for CSNI regarding facility utilisation through programmes that could be pursued internationally. In particular, the Group agreed on the main criteria for priority setting, which was based on the following items [high, medium or low (H, M, L) for each item]:

- a) relevance of the facility to cover a specific issue,
- b) uniqueness (e.g. one of a kind for in-pile testing),
- c) availability for a potential programme addressing the issue,
- d) readiness (e.g., staff available to run it),
- e) operating cost (<0.3, 0.3-1, >1M\$), or construction cost (<0.5, 0.5-2, >2M\$).

TAREF members that had proposed facilities were requested to characterize their proposed facilities in relation to the above criteria. Based on this, the Group recommendations for CSNI were developed.

Conclusions and recommendations

1. The TAREF task proved to be a useful exercise for gathering consensus on the technical areas and issues related to the safety of GCR systems, as well as for identifying a number of facilities that are or will become available in OECD member countries for supporting GCR safety research.
2. Existing facilities and facilities that are being constructed or planned in member countries cover all technical areas of concern and most of the safety issues identified in these areas. Hence, there is no apparent need for CSNI to build a facility (beyond what is currently planned in member countries).
3. Based on the responses received, the facilities that were among the most high ranked were identified. These facilities are shown in the following Table.

TAREF GCR Summary Ratings

	Accident and thermal fluids	Fission product transport	High-temperature materials	Graphite and ceramics	Fuel
Czech Republic		HTHL	HTHL	HTHL	
France (*)	HEDYT ENIGMA	MERARG		HEDYT	PLINIUS
Germany	HELOKA A2	THAI	High Power Laser Lab		
Italy	HE-FUS3				
Japan	HTTR	HTTR	HTTR		NSRR
USA		ATR	ORNL materials lab INL High Temp Test Lab	MIT Reactor HFIR	ACRR ATR MIT Reactor

* For the longer term (2020 and beyond), the French GFR demonstration reactor ALLEGRO should also be considered.

4. The Japanese HTTR constitutes a unique resource in that it is the only experimental high-temperature GCR available for a test programme in the OECD countries. It is a graphite-moderated, helium cooled reactor that can reach temperature as high as 1 600°C in some transient conditions. The experiments planned by JAEA to study effects of RCCS performance reduction are highly relevant for HTR safety assessments. The HTTR is also suitable for neutronics, fission product release and graphite dust issues related to prismatic fuel arrangements. Actions should be taken to develop an international programme focused on the HTTR capabilities and on the safety issues identified in the present task.
5. The Czech loop HTHL offers the opportunity to host separate effect tests carried out both out of pile and in-pile, hence offering the flexibility to address studies in which the combined effect of high-temperature gas environment and radiation are of relevance, such as for instance on fission product transport or high-temperature materials.
6. The HTTR and the HTHL plans are suitable for near term initiatives, i.e. for proposals that could result in defining an experimental programme in a 1-2 year time frame. Following current practice of CSNI projects, this action depends on the initiative of the host country and facility, as well as on co-operative support from other member countries. The NEA support to set up such programmes will be required.
7. Relevant CSNI Working Groups should be encouraged to share modelling information and discuss modelling activities relevant for GCR safety, in order to help focus the potential test programmes and/or enhance the data utilisation for model developments.
8. An activity in the field of thermal fluids and fission product behaviour in a GCR environment should be considered in the Working Group on Analyses and Management of Accidents (WGAMA), which has the advanced reactor item on its agenda. This activity may consist of a state-of-the-art assessment or of an international standard problem regarding GCR safety issues. This activity could help define medium-term initiatives (3-5 years) for an analytical or experimental international programme in specific areas of interest.

1. INTRODUCTION

1.1 Background

In June 2007, the OECD NEA Committee on the Safety of the Nuclear Installations (CSNI) and the Committee on Nuclear Regulatory Activities (CNRA) held a joint Workshop on the Role of Research in a Regulatory Context (RRRC-2), addressing the needs and priorities for nuclear safety and regulatory research. Among others, the Workshop discussed high priority safety issues for current plants and for new reactor construction, identifying focus areas for future research. It also considered the challenges that the nuclear community could face in the long term for performing safety evaluations of advanced reactor designs, the possible means for organising and conducting the needed research and for developing the related infrastructure. In the context of advanced reactors, the workshop discussed research topics relevant for gas-cooled and sodium fast reactors and provided a set of recommendations for CSNI initiatives, considering the experience and the good record gained by the CSNI in promoting and managing international safety research projects [1]. In particular, it was recommended that the CSNI develop a strategy and approach for conducting collaborative programmes to support the safety assessment of advanced gas-cooled and sodium fast reactors. The proposed strategy was to define:

- key safety issues as related to specific design concepts;
- issues that will likely require additional research;
- facility infrastructure needed for developing the required data.

The CSNI further discussed these topics at its December 2007 meeting. As stated in the summary record of that meeting, “although the deployment of the Gen-IV systems is not expected in the short-term, the CSNI agrees that initiatives should be taken to identify the technical and safety issues that will likely need to be addressed for these systems [2]. To facilitate this effort, the CSNI established a Task Group to provide an overview of facilities suitable for carrying out safety research on gas-cooled and sodium-fast reactors”. The task, created in spring 2008 and denominated as Task on Advanced Reactor Experimental Facilities (TAREF), was to focus on gas cooled reactors (GCR) and sodium fast reactors (SFR). Other reactor systems could be considered in a subsequent phase.

The countries that expressed interest in participating in the task were:

Canada	China	Czech Republic	Finland	France	Germany
Hungary	Italy	Japan	Korea	United States	

The TAREF task follows a similar activity conducted by the CSNI and described in the report entitled *Nuclear Safety Research in OECD Countries: Support Facilities for Existing and Advanced Reactors (SFEAR)* [3], which was issued in 2007 and which focused on facilities suitable for current and advanced water reactor systems. In a subsequent Collective Opinion Statement on the subject, the CSNI recommended a similar exercise be conducted for Gen-IV designs, aiming among others to develop options on how to efficiently obtain the data that are needed, hence “better preparing the CSNI to play a role in the gradual extension of safety research beyond the needs set by currently operating reactors” [4].

As explained in a subsequent section, the present report has been structured in a manner similar to the SFEAR report mentioned above, primarily in that the main focus is on a set of identified safety issues and hence on recommendations for facility utilisation as related to these issues.

At the first Task Group meeting, it was decided that the GCR-related task could be completed at an earlier stage than the SFR task, considering that a significant number of the safety issues had already been compiled by the USNRC [5]. Hence it was decided to produce two separate task reports, i.e. the present one on GCRs and a following one on SFRs – the latter being scheduled for the end of 2010. Dr. Jennifer Uhle of the USNRC and Ms. Joelle Papin of the French IRSN were elected as task Chairpersons and led the effort for the GCR and the SFR part of the task respectively.

1.2 Purpose

Advanced reactors incorporate design features, materials and safety provisions that are likely to require exploratory experiments, confirmatory tests and analytical verification. In order to perform this work, adequate infrastructure must be available including facilities, analytical models and expertise. The main purpose of this task is the identification of facilities – as well as recommendations for an optimal development and utilisation of such infrastructure – in order to produce the necessary data in a timely manner as required for safety assessments and licensing purposes.

The TAREF objectives are as follows:

1. to provide an overview of existing or planned facilities suitable for safety research investigations relevant for advanced reactors, with focus on GCRs and SFRs;
2. to summarise the Phenomenon Identification and Ranking Tables (PIRT) that have already been carried out in the GCR thermal-hydraulics and fuels areas;
3. to perform a similar PIRT for the SFR¹;
4. to propose recommendations for an efficient utilisation of facilities and resources for meeting short and long term safety research priorities.

This activity is considered important for achieving one of the main goals of the CSNI, which, as described in its Operating Plan, is to help maintain – and if necessary create – the infrastructure and expertise needed to ensure the continued safety of the nuclear power production [6]. This goal can be achieved, in part, by developing a better understanding of the relevant safety issues through co-operative research carried out in specialised facilities and involving internationally recognised experts.

1.3 Scope

The scope of this activity is limited to technical issues and facilities associated with the safety assessment and operation of nuclear gas-cooled reactors in the OECD member countries. In the CSNI Operating Plan perspective, it covers the following main safety issues and topics:

- new concepts of operation;
- new risk perspectives and safety requirements;
- fuel safety;
- new materials and fabrication technologies;
- transparency of the technical basis for safety assessment;
- maintenance of experimental facilities to address emerging safety issues.

1. In developing the Task, it was decided (first meeting) that a full PIRT for SFRs was not necessary for the TAREF purposes, and that the Group would instead produce a set of relevant SFR safety issues in a manner similar to that used to produce the SFEAR report.

The Task Group adopted the approach of the PIRT performed by the United States Nuclear Regulatory Commission (USNRC) [5,10], and consistent with that approach, identified the following technical areas to be addressed:

- A. accident and thermal fluids (including neutronics);
- B. fission-product transport;
- C. high-temperature metallic materials;
- D. graphite and ceramics;
- E. fuel (Tristructural-isotropic (TRISO) and other fuel types).

The technical areas A, B and E address phenomena and issues that are specific to the nuclear industry. The other two technical areas (C and D) address phenomena and issues that are relevant for the nuclear industry, but for which experience may be broader than nuclear.

Other technical areas such as seismic assessment (except for potential consequences on core compaction in a pebble bed design), fire assessment, instrumentation and control and human and organisational factors are not treated here, since they are not specific for the nuclear industry and – within the nuclear area, not specific for GCRs. They were addressed only in broad terms in the SFEAR report, which can be consulted for generic information regarding these areas [3]. Finally, the segment of a GCR plant dealing with process heat utilisation production (such as used for hydrogen production) has not been included in the present assessment, primarily because the areas of concern are not specific for the nuclear industry and because the interaction of the nuclear island and the process heat utilisation facility can be addressed based on information that do not appear to require specific experimental facilities.

1.4 Approach

As an initial step, the TAREF participants compiled a questionnaire regarding the technical infrastructure that is potentially suitable for experimental studies on GCR safety. The questionnaire basically addressed the existence of experimental small scale separate effect facilities or large scale integral facilities – or of plans for their construction – as related to areas such as:

- thermal-fluid issues including neutronics;
- computational fluid dynamics (CFD) code validation;
- fission product release and transport;
- fuel behaviour.

The existence of relevant data and readiness to share them, as well as the willingness to participate in joint international efforts on experimental work were also addressed in the questionnaire. The outcome of the questionnaire was discussed during the first TAREF meeting and served as an initial basis for structuring the task.

In addition, the USNRC made the results of the PIRT it conducted for high-temperature gas reactors available to the Group [5,10]. The main PIRT outcome was reviewed and to a considerable extent adopted for orienting the Task Group activity including, as mentioned earlier, the main technical areas that the Task Group focused on.

For each of these technical areas, the task members agreed on a set of safety issues needing research. Only the issues identified as being of high safety relevance and for which the state of knowledge is low or medium were included in the discussion, as these issues would likely warrant further study.

For each of the safety issues, task members identified the related facilities – available or planned – that were deemed appropriate to address the issues in question, providing relevant information such as operating conditions (in- or out-of-reactor), operating range, description of the test section, type of testing, instrumentation, current status and availability, uniqueness, etc.

The Group agreed on the main criteria for priority setting, which was based on the following items [High, Medium or Low (H, M, L) for each item]:

- relevance of the facility to cover a specific issue;
- uniqueness (e.g. one of a kind for in-pile testing);
- availability for a potential programme addressing the issue;
- readiness (e.g., staff available to run it);
- operating cost (<0.3, 0.3-1, >1M\$), or construction cost (<0.5, 0.5-2, >2M\$).

The task members set up a ranking of the proposed facilities based on the above criteria, and developed recommendations for the CSNI regarding priorities and options for facility utilisation and programmes that could be pursued through international undertakings in the near, medium and long term. The Group rated those facilities that were costly to either operate or construct as being ranked high in this category as they were more suitable to host a multilateral co-operative programme than facilities of lower cost that could be supported by one country without the need to organise a collaborative programme.

1.5 Co-ordination

In assembling the information contained in this report the TAREF participants have the benefit of input from the CSNI Working Groups (WGAMA on fluid dynamics and accident issues, WGFS on fuel issues and WGIAGE on structural material issues) and from CSNI members. In addition, the CNRA and external organisations (IAEA and others) were offered an opportunity to comment on a draft of the report.

1.6 Organisation of the report

The remainder of this report is organised as follows:

- Chapter 2 provides a short overview of the high-temperature reactors (HTR) (representative also for the very high-temperature reactors (VHTR)) and of the gas fast reactors (GFR).
- Chapter 3 contains an outline of the five technical areas and a description of the associated safety issues, explaining the main phenomena involved and the safety implications. As mentioned earlier, only issues of high importance and low-to-medium knowledge have been considered. Chapter 3 also contains the list of facilities identified for each safety issue.
- Chapter 4 presents the Group's conclusions and recommendations regarding CSNI options for facility utilisation, including initiatives for international experimental programmes in support of safety assessments.
- The Appendices contain concise facility information provided by the members, the TAREF terms of reference, the Group composition and the summary of the two TAREF meetings that were held before issuing the report.

2. OUTLINE OF REFERENCE GAS-COOLED REACTORS

2.1 Introduction

In the following, two GCRs, namely the HTR and the GFR, are briefly described in terms of their main plant and core characteristics. The HTR description is derived from the USNRC PIRT [5,10] and, for the purpose of this task, covers also the VHTR design. The GFR description has been provided by the French Commissariat à l'énergie atomique (CEA) [7].

2.2 Outline of the HTR

The typical HTR design features include the following [5]:

- High-performance coated fuel particles (CFPs) with the capability of containing the fission products for the full range of operating and postulated accident conditions, with a very low fuel failure fraction and subsequent release of fission products. The CFPs are embedded in either a rod compact inserted into a stacked prismatic block or a spherical compact that constitutes a pebble.
- An inert single-phase high-pressure coolant (helium).
- A graphite-moderated core with the characteristics of low power density, large heat capacity, high effective core thermal conductivity, and large thermal margins to fuel failure.
- Negative fuel and moderator temperature coefficients of reactivity, which together with the negative reactivity feedback of the fission product xenon-135, are sufficient to shut down the reactor during loss-of-forced circulation (LOFC) events. This aspect provides for stabilising power-control feedback for most reactivity insertion events (for both startup and power operation) for the entire fuel life cycle and for all applicable temperature ranges.
- A design basis accident decay heat removal system, typically a passive system utilising natural-convection-driven processes (the reactor cavity cooling system – RCCS).
- A confinement-style reactor building structure to accommodate depressurisations may be used instead of a leak tight sealed containment.
- The HTR core design is either prismatic or pebble bed.
- The balance of plant (BOP) consists of an electrical power generation unit (most likely a gas turbine) and, possibly, a high-temperature process heat component potentially used for the production of hydrogen.

If applicable, coupling of the reactor to the hydrogen plant will be via an intermediate heat exchanger (IHX) and a long heat transport loop, with various options for the transport fluid. Figure 2.1 shows a sketch of the HTR concept highlighting the reactor, power conversion, and the process heat loop (depicted as a hydrogen production unit). The figure also shows examples of the two types of HTR reactor cores, prismatic, and pebble bed, respectively.

Figure 2.1 Schematic of the HTR arrangement and fuel options

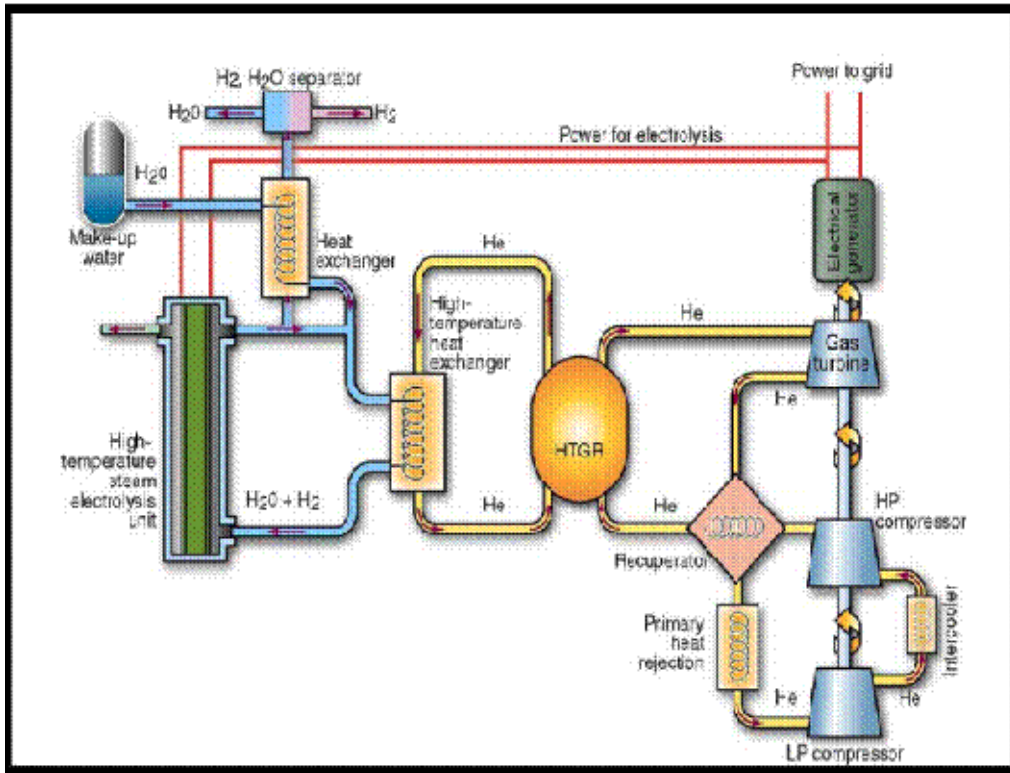

Prismatic fuel



Pebble bed fuel

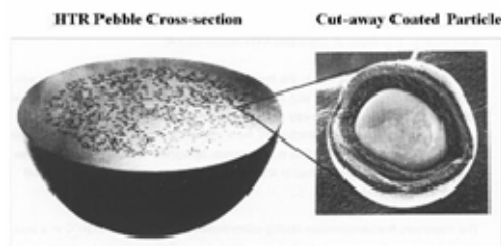

In a prismatic reactor (PMR) design, fuel elements consist of fuel compacts inserted into holes drilled in graphite hexagonal prism blocks ~300 mm across the flats and 800 mm long, interspersed with coolant holes. In a pebble bed reactor (PBR) design, fuel elements are 6-cm-diam spheres containing a central region of TRISO fuel particles in a graphitized matrix material, surrounded by a 5-mm protective outer coating of graphitic material. The pebble bed concept was developed initially in the United States in the 1950s and later further developed in collaboration between Germany and the United States in the 1960s. The pebble bed concepts employ continuous refuelling, with pebbles typically recycled ~6 to 10 times, depending on measured burn-up.

A major component in the plant, the IHX, is required for coupling the primary high-temperature, high-pressure helium system to either the indirect gas-turbine system and/or the process heat component and must be designed to operate at very high-temperatures. There is the potential for large pressure differences between the IHX primary and secondary sides – at least in transients and perhaps for long-term operation.

There are multiple methods to produce hydrogen using heat, heat and electricity, and electricity-only using nuclear energy. Candidate processes include steam reforming of natural gas, electrolysis, high-temperature electrolysis, and hybrid-sulphur or sulphur-iodine thermo-chemical extraction. There are also multiple markets for high-temperature nuclear process heat and hydrogen which can have a strong influence on the safety challenges associated with co-locating a nuclear plant and hydrogen plant. Several different types of chemical plants might be coupled to the reactor over its lifetime to meet different needs.

Several confinement and containment options have been investigated in the past, with the vented confinement option generally treated as a baseline (with or without filters). Any early fission product release in a depressurisation accident is usually assumed to be small, requiring no holdup, while any delayed releases are assumed to be larger, but modest, with very little pressure difference to drive fission products out into the environment.

2.3 Outline of the GFR

The GFR system features a high-temperature helium cooled fast spectrum reactor with a direct-cycle helium turbine or an indirect cycle using an IHX for electricity production (Figures 2.3 and 2.4). It uses a closed fuel cycle. The GFR combines the advantages of fast spectrum systems (long term resource sustainability, in terms of use of uranium and waste minimisation, through fuel reprocessing, recycling, and burning of long-lived actinides) with those of the high-temperature reactors (high thermal cycle efficiency and possibly hydrogen production), and of the direct-cycle energy conversion option.

Its development approach is to rely on technologies already used for the HTR but with significant advances, in order to reach the objectives stated above. Thus, it calls for specific research and development (R&D) beyond the foreseen work for thermal HTR/VHTR.

The main GFR design specifications as derived from the general objectives of Generation IV systems are:

- use of gas as a coolant as a means of reaching high-temperatures;
- economic competitiveness by means of simplicity, compactness and efficiency;
- a robust safety demonstration, based on probabilistic safety assessment and defence in depth principles, and including severe accident management.

Additional design specifications of the GFR include:

- Fast neutron spectrum core with a zero (self-breeding) or positive breeding gain, with no or very limited use of fertile blankets in order to:
 - generate as much fissile material as it consumes, with an optimal use of uranium;
 - have a fuel cycle fed with only depleted or natural uranium;
 - achieve homogeneous recycling of all actinides, in order to have no separation of plutonium from other actinides (proliferation resistance).
- Core plutonium inventory not exceeding 10 tons/GWe, in order to have a realistic reactor fleet deployment (in a few decades) and high fuel burn-up.

In the HTR the use of graphite increases the thermal inertia of the core, thereby limiting the maximum temperature during transients. On the other hand, GFR cores have relatively low thermal inertia; design features aimed at overcoming this apparent unfavourable feature include:

- A fuel element based on refractory materials and high thermal conductivity, with the ability to ensure radioactive material confinement up to very high-temperatures.
- A primary circuit design based on upward core cooling and a moderate pressure drop for all the primary components and circuit involved in accident scenarios. One essential parameter for safety system performance is gas pressure. The primary helium is pressurised to 7 MPa under nominal conditions. A gas tight envelope enclosing the primary circuit has been added in order to limit the loss of pressure in case of primary loss of coolant. Maintaining high helium density allows the decay heat removal system to rely on moderate pumping power and even on passive natural convection in some situations.

The fuel element is able to withstand high operating temperatures and transients associated with the poor heat capacity of the gas coolant. The main temperature limits are the following:

- An operating temperature, around 1 000°C, that provides a sufficiently ample margin to failure.
- A boundary temperature of 1 600°C below which fission product release is prevented.
- An upper temperature of 2 000°C below which the core geometry can safely be cooled down.

Concerning the objectives of ultimate waste minimisation, proliferation resistance and natural resources optimisation (zero or positive breeding gain), the major corresponding reactor design options are:

- No fertile blanket and multi-pass recycling of all actinides without separation.
- Loading of 1.1% of Minor Actinides (corresponding to self-recycling).
- A high density fuel with maximisation of actinide content.
- High core power density of about 100 MW/m³.
- A high core power unit of 2 400 MWth (for economic reasons).
- Mean overall core burn-up: 5% FIMA (Fission of Initial Metal Atoms).

Fuel element: At least two fuel concepts have the potential to fulfil the above requirements, that is: a ceramic plate-type fuel element (Figure 2.2) and a ceramic pin-type fuel element. The reference material for the structure is reinforced ceramic, a silicon carbide (SiC) composite matrix ceramic. The fuel compound is made of pellets of mixed uranium-plutonium-minor actinide carbide. A leak-tight barrier made of a refractory metal or of a Si-based multi-layer ceramics is added to prevent fission product diffusion through the clad.

Core design and performance: The core layout (246 fissile sub-assemblies, 24 control rods) has been chosen to be consistent with the maximum power derived from thermo-mechanical/thermal-hydraulic analyses, the requirements of the reactivity control system and the optimised power distribution. The main characteristics of a reference core are summarised in the table below [8].

Figure 2.2 View of the fuel plate type element for GFR, made of two ceramic plates enclosing a honeycomb structure containing cylindrical pellets made of the mixed carbide



The alternative pin-type fuel is a well-known concept and it is possibly less challenging from a technology standpoint. The design is to be optimised in order to enhance performance.

**Table 2.1 Main GFR characteristics
GFR 2 400 MWth, Referene core**

CORE – SUB-ASSEMBLY	
H/D fissile core	0.62
Inter-assembly gap (mm)	3
Fissile height (mm)	2 349
Helium blade thickness between two plates (mm)	4.00
FUEL ELEMENT	
Plate thickness (mm)	8.4
Clad thickness (mm)	0.85
Internal liner (µm)	40+10=50
Pellet diameter (mm)	11.285
Pellet height (mm)	6.5
OPERATING CONDITIONS	
Core pressure drop (MPa)	0.14
Tmax fuel (°C)	1 318
Tmax clad (°C)	920
CERAMIC PLATE CORE – MAIN FEATURES	
TRU enrichment (%)	18.2
Core management (eq. full power days)	3×600=1 800
Average discharge burn-up (at% FIMA)	6.7
Breeding gain	-0.03

Figure 2.3 GFR primary system overview

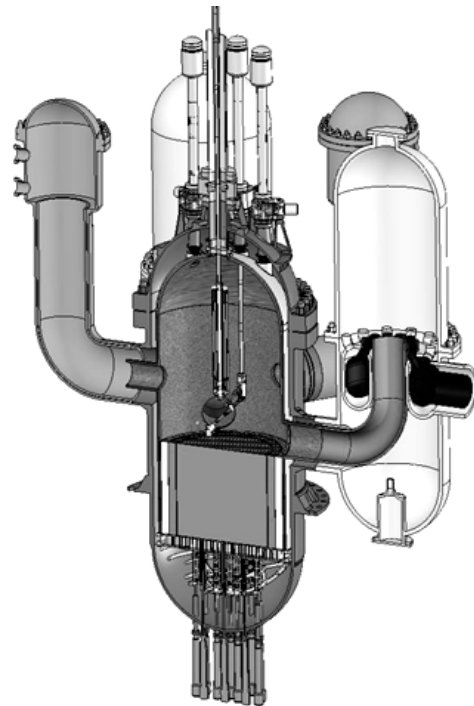

Primary system: The reactor pressure vessel is a large metallic structure (inner diameter 7.3 m, overall height 20 m, weight about 1 000 tons, and thickness of 20 cm in the belt line region). The material selected, a martensitic 9Cr-1 Mo steel (industrial grade T91, containing 9% by mass chromium, and 1% by mass molybdenum) undergoes negligible creep at operating temperature (400°C). The reference material for the internals is either 9Cr-1Mo or stainless steel, typically SS316LN. The global primary arrangement is based on three main loops (3×800 MWth), each fitted with one IHX–blower unit, enclosed in a single vessel (Figure 2.3).

The shutdown system is derived from the European Fast Reactor (EFR) [9] with two redundant and passive shutdown systems (no power supply, gravity drop of absorber elements). Each main control rod and shutdown device and diversified shutdown device is individually driven, considering two independent groups each connected to a dedicated group of the instrumentation and control support system.

The fuel handling system is based on a jointed arm system, with fuel element loading and unloading using a fuel storage drum via lock chambers, while the vessel remains closed.

Specific loops for emergency decay heat removal are directly connected to the pressure vessel, and are equipped with heat exchangers and blowers.

The gas tight envelope is designed to provide a sufficient pressure in the case of a large gas leak from the primary system. It consists of a metallic structure, initially filled with nitrogen slightly over atmospheric pressure to reduce the possibility of air ingress.

Power conversion system: the current choice is the indirect combined cycle with He-N₂ mixture for the intermediate gas cycle. The cycle efficiency is approximately 45%, based on assumed component efficiencies and pressure drops. A schematic view of this power conversion system is shown in the figure below.

Figure 2.4 Schematic of the power conversion system bases on indirect combined cycle with He-N₂ mixture for intermediate gas cycle

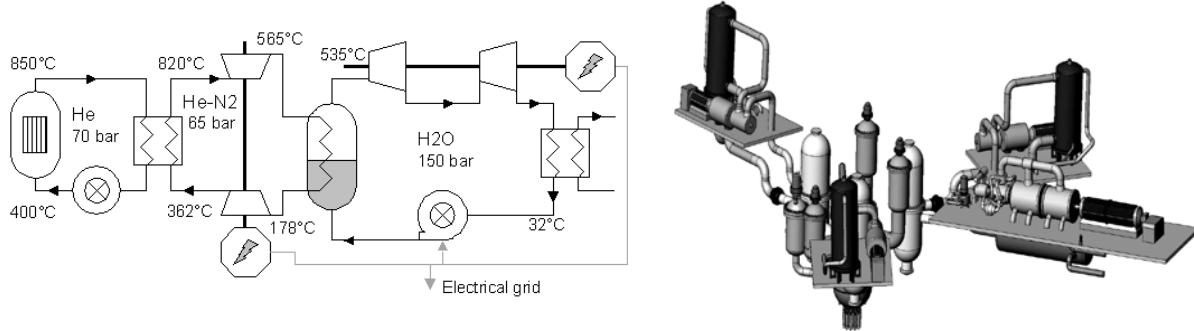

3. TECHNICAL AREAS, SAFETY ISSUES AND FACILITIES

3.1 Introduction

The basic safety design approach for HTRs is different from most currently operating and advanced light water reactors (LWRs). HTRs rely on the retention of fission products in high integrity ceramic-CFPs in a relatively chemically inert environment to withstand accidents without fuel damage or fission product release. To effectively retain fission product within the CFPs during accident conditions, HTRs are designed with passive heat removal systems and inherent negative reactivity to limit fuel temperatures and maintain fuel particle integrity. However, with these novel design features and characteristics, HTR designers must provide proof of the safety performance of the equipment including the CFPs, integrity of the reactor vessel and supporting safety-related structures, systems and components. Fission product release and transport behaviour must be well understood and analysis tools must be validated against an adequate database if a vented confinement is to become an acceptable feature of an HTR.

To identify the phenomena, processes and issues that must be understood for an HTR, the USNRC, sponsored a phenomena identification and ranking table (PIRT) exercise. The PIRT process provides information on important safety phenomena and identifies gaps in the available information and data needed to model the phenomena. The U.S. Department of Energy (USDOE) and the USNRC sponsored a PIRT process for HTRs in each of the following topical areas:

- accident and thermal fluids;
- fission-product transport and dose;
- high-temperature materials;
- graphite;
- process heat and hydrogen co-generation production.

Panel deliberations and rationale for the ratings are documented in NUREG/CR-6944 [5]. In addition, the USNRC sponsored a PIRT for TRISO fuel [10]. Phenomena important to safety systems and components were identified and figures of merit were established. The panels rated (as high, medium, or low) the importance and the associated knowledge level of the phenomena. For instance, if a phenomenon was concluded to be of high importance but limited knowledge exists about the phenomenon, it would be ranked as high importance, low knowledge or H, L. This section describes the technical areas and the issues associated with each area. The PIRTs are used as the basis for these issues. The five technical areas addressed in this section are:

- A. accidents and thermal fluids (including neutronics);
- B. fission-product transport;
- C. high-temperature metallic materials;
- D. graphite and ceramics;
- E. fuel.

Because of the importance of fuel performance, and fission product transport in HTR analysis, the PIRT for “fission product transport” was divided into two related technical areas. In this report “fission product transport” refers to phenomena and processes in the primary system and containment that contribute to transport of fission products from the core to elsewhere in the primary system and beyond the containment boundary. “TRISO Fuel” or “ceramic fuel” refers to the phenomena and processes that result in fuel element (particle of plate or pin) failure and the diffusion and migration of fission products within the TRISO CFPs, graphite fuel matrix, and nuclear graphite fuel blocks (for HTRs with prismatic block cores).

The emphasis in this section are on processes that were identified and highly ranked in importance in the PIRTs and were considered low in terms of knowledge level, except for hydrogen production and process heat. High importance processes with moderate or low knowledge level can be expected to require additional investigation and experimental data to support the safety evaluation of a HTR design.

3.2 Description of technical areas and related safety issues

3.2.A.1 Accidents and thermal fluids

Accidents and thermal fluids (ATF) refers to thermal-fluid phenomena associated with the reactor system, such as passive cooling of the core by conduction, convection, and thermal radiation, and cooling of the reactor pressure vessel via the reactor cavity cooling system (RCCS). Material properties associated with heat transport were included as thermal-fluid phenomena due to their importance in heat transport.

Because many phenomena are dependent on a specific geometry and accident initial and boundary conditions, the thermal-fluids PIRT considered both the PBR and the PMR design concepts as well as a range of accident scenarios. In addition, while the focus of this section is on thermal-fluid phenomena, it also considers neutronic phenomena where appropriate. The remainder of this section describes the phenomena and processes of interest in the general area of thermal-fluids.

Phenomena identification in postulated accident sequences involved determination of factors important to the outcome of the events. For modular HTRs, which rely largely on inherent (passive) safety features, the important phenomena include physical characteristics such as material thermal conductivity, radiation heat transfer aspects such as emissivity, and temperature-reactivity feedback coefficients rather than on the actuation of mechanical or electrical components to halt accident progression. These phenomena involve combinations of several mechanisms of heat transfer in various geometric configurations. Effective pebble bed core thermal conductivity, for example, involves radiation heat transfer in addition to conduction, which is a function of irradiation. A qualitative judgment of a phenomenon's importance is not always straightforward since for some specific scenarios it may be crucial to an outcome, while in other scenarios it may not be a factor. Therefore, a range of possible scenarios were examined.

Consideration of a wide range of postulated accidents was based on a review of HTR safety analysis reports. The scenarios selected for consideration by the ATF PIRT were as follows:

- pressurised loss-of-forced circulation (P-LOFC) accident;
- depressurised loss-of-forced circulation (D-LOFC) accident;
- D-LOFC followed by air or water ingress;
- reactivity-induced transients, including anticipated transients without scram (ATWS);
- events related to coupling the reactor to the process heat plant.

Because of their importance in defining the initial conditions for a scenario, normal operation of a HTR system was also considered as a separate scenario. Normal operation refers to steady-state, routine load changes, startup and shutdown, and other conditions and transients not involving failures of safety-grade systems or components. Some event sequences nominally classified as anticipated operational occurrences (AOOs) fall into this category.

Consideration of P-LOFC and D-LOFC events leads to the development of a general LOFC table (G-LOFC) that included common elements for the variations on both types of LOFC scenarios. RCCS behaviour is generally very important in LOFC events because the RCCS becomes the means of removing decay heat from the core and vessel. The processes are generally the same for variations in the LOFC, but some differences exist, such as the heat redistribution in the core and vessel for the P-LOFC (hotter at the top), potential for “gray gas” (particulates) in the air cavity between the vessel and RCCS that reduces the effective emissivity, and potential mode changes (e.g., to and from boiling) in a water-cooled RCCS.

When the USDOE and USNRC developed the PIRTs [5,10], the studies did not consider designs having steam generators or other water-cooled equipment directly connected to the primary. However, this design choice was considered by the TAREF members. Therefore, D-LOFC events and the accompanying effect of water ingress on reactivity and chemical reaction with graphite is discussed in this report.

The importance ranking of a given phenomenon (or process) was based on the effect it had on one or more figures of merit or evaluation criteria. These included public and worker dose, fuel failure, and primary and other safety system integrity. The major HTR safety issues of concern that were identified and categorised as high importance combined with medium to low knowledge can be summarised as follows:

- core coolant bypass flows (normal operation);
- power/flux profiles (normal operation);
- outlet plenum flows (normal operation);
- reactivity feedback coefficients (normal operation and accidents);
- emissivity aspects for the vessel and RCCS (D-LOFC);
- reactor vessel cavity air circulation and heat transfer (D-LOFC);
- convection/radiation heating of upper vessel area (P-LOFC).

For GFR systems, a specific characteristic is the lack of thermal inertia of the primary system, combined with the pressurised gas and the associated risk of leakage. From a thermal-hydraulic point of view P-LOFC and D-LOFC are two main categories of transients that strongly influence the design of the system. Safety of the reactor mainly relies on active systems, and progression of a transient depends on the characteristics of several critical components. Hence, the behaviour of these safety critical components is a relevant GFR safety issue. In consideration of the fast neutron environment, the GFR core physics is sensitive to several reactivity effects, a consideration that requires specific attention as related to e.g. water ingress or reactivity effects resulting from accidental conditions. In this context, there will be a need of accurate nuclear data for GFR materials at representative neutron spectrum conditions.

The GFR-specific safety issues in the area of accidents and thermal fluids are as follows:

- GFR accident scenarios and natural circulation;
- GFR behaviour of critical components;
- reactivity effects resulting from accident events;
- nuclear data on specific GFR materials and spectrum conditions.

Section 3.2.A.2 discusses each issue identified for HTR and GFR reactor systems, and briefly describes its safety significance.

3.2.A.2 Description of safety issues in the accidents and thermal fluids area

Safety issues	Description
Core coolant bypass flow	<p>This refers to the fraction of the total primary coolant flow that does not directly cool the fuel elements. In the PMR, direct cooling is done by the flow through the fuel element cooling holes, and in the PBR, it is the flow through the main annulus containing the fuel pebbles. In annular core designs, bypass occurs at the side and central reflector interfaces. The bypass flow is typically very difficult or impossible to measure in HTRs because most bypass flow is through the spaces between fuel and reflector blocks. The bypass flow area can vary with temperature, temperature gradient, and block shrink/swell effects due to irradiation. In PBRs bypass occurs along the pebble-wall interfaces where the pebble packing is less than that in the center of the annulus. While important in normal operation, the bypass flow fraction may be an insignificant factor in D-LOFC accidents, thus providing a good example of how one phenomenon can be of high importance in one case and low in another. The major safety-related concern due to core coolant bypass in the normal operation category is the possibility of operating fuel temperatures being significantly higher than expected. Flow diverted into bypass flow paths is unavailable for cooling the fuel and the reduction in expected convective heat removal may result in high-fuel temperatures.</p>
<p>A.2 <i>Power/flux profiles in PBRs</i></p>	<p>This is a highly ranked process with low knowledge level for normal operation. For both PBR and PMR designs, the panel was concerned with the reactivity-temperature feedback coefficients and the relative lack of experimental data for this core configuration and the eventual large plutonium content due to the use of low-enriched uranium (LEU) (and no thorium). These coefficients (for fuel, moderator, and reflector) are important for establishing inherent reactivity control safety, and vary with temperature and burn-up. The panel was also concerned with the potential for high power peaking near the reflector interface, and uncertainties in the PBR local power due to the stochastic nature of the pebble arrangement. Power/flux profile is a safety significant concern due to the history of predicting operating temperatures in the Atomgemeinschaft Versuchs Reaktor (AVR) and the lack of operating experience with tall annular cores. As with bypass flow, uncertainty in calculating the power/flux profile can lead to an under-prediction of fuel temperatures.</p>
<p>A.3 <i>Outlet plenum flows</i></p>	<p>The outlet plenum flow is a normal operation process with high importance and low knowledge level. This process refers to the temperature differences in the coolant discharges from the bottom of the core can be large due to variations in both axial flows and radial peaking factors, and can lead to both steady-state and fluctuating jets in the lower plenum.</p> <p>The outlet plenum flow distribution represents a safety significant issue because of the thermal stresses that the distribution may generate in core support structures and the vessel wall. Thermal stress and cycling is also a concern for the outlet duct and the downstream gas turbine.</p>

Safety issues	Description
<p>A.4 <i>Reactivity feedback coefficients for normal operation and accidents</i></p>	<p>These phenomena are considered important in HTR analysis for several reasons. As discussed earlier under <i>power/flux profiles</i>, reactivity feedback coefficients are important for determining local power during normal operation. For PBRs, an anticipated transient without scram (ATWS) case of interest is a reactivity insertion due to pebble bed core compaction in a severe earthquake. Bounding calculations of the potential positive reactivity insertion have shown that significant positive reactivity could theoretically result. However, the reactivity increase would be expected to occur over a relatively long-time period (minutes). Even without a scram or other corrective action, the natural negative temperature-reactivity feedback mechanisms are expected to mitigate damaging power excursions.</p> <p>The possibility of positive reactivity insertions from steam or water ingress was also considered. Depending on design and operating conditions, the ingress may or may not cause a significant positive reactivity insertion. In the PIRT exercise, it was assumed that credible mechanisms for significant ingresses (during reactor power operation) did not exist because the potential water sources would remain at pressures lower than those in the primary system, and water inventories in the secondary systems were assumed to be limited to small values by design. The conclusion was predicated on the assumption that the design does not include a steam generator in the primary circuit. There were no (H, L) panel rankings in this category. However, the TAREF members considered the potential for steam/water ingress and rated this phenomenon as (H, L) due to the potential for positive reactivity insertions complicated by the potential for exothermic reaction contributing to temperature increases. It was concluded that there is virtually no data available to model this phenomenon, so it was given a low knowledge level ranking. The reactivity-temperature feedback coefficients for the fuel, moderator, and reflectors were ranked as (H, M). This negative feedback is crucial to the inherent defenses against reactivity insertions, and due to the complex and untested (to date) design features such as the very tall annular core, there were some predictability concerns, particularly for high burn-up conditions.</p>
<p>A.5 <i>Emissivity aspects for the vessel and reactor cavity cooling system</i></p>	<p>The emissivity aspects of the vessel and reactor cavity cooling system are considered important in both P-LOFC and D-LOFC events. One phenomenon in this category ranked by the panel as (H, L) was the emissivity for the vessel and RCCS panels. Emissivities are key factors in determining the heat removed to the ultimate heat sink, and uncertainties arise due to ageing effects. Accurate estimation of the emissivities in LOFCs is important because at high-temperatures most of the heat removal (80% to 90%) is by thermal radiation to the RCCS. The rest of the heat removal occurs due to convection. Steels have been shown to have high emissivities (0.8) at high-temperatures given that an oxide layer (typically formed in most service conditions) is intact. However, there was concern that this layer, particularly for surfaces inside the vessel in a relatively pure helium atmosphere might be significantly lower than expected.</p>

Safety issues	Description
<p>A.6 <i>Reactor vessel cavity air circulation and heat transfer</i></p>	<p>Reactor vessel cavity circulation and heat transfer is a process representing several phenomena important during both P-LOFC and D-LOFC as well as during normal operation. In normal operation, conditions could lead to persistent unexpectedly high-temperatures in reactor cavity concrete, or cause severe thermal gradients or temperature fluctuations. This was noted as a general concern for RCCS performance (ranked H, M). These included concerns for potential RCCS panel differential expansion/contraction problems and cooling water flow distribution disparities, especially in horizontal regions such as at the top of the reactor vessel cavity. During a D-LOFC, dust suspension in the reactor vessel cavity due to dust entrained by the helium discharge could impede the radiant heat transfer from the vessel to the RCCS. This phenomenon was rated (H, M) by the ATF panel, considering the difficulty of predicting geometry and deposition effects.</p>
<p>A.7 <i>Convection/radiation heating of upper vessel area</i></p>	<p>Heating of the upper vessel area refers to several processes that occur during a P-LOFC. During a P-LOFC forced circulation of the helium coolant stops while the system remains at normal operating pressure. Heat from the core is removed by natural circulation of pressurised helium which tends to equalise core temperatures. This prevents the formation of local hot spots in the core, as would happen in D-LOFC cases, where the heat transfer mechanism is primarily conduction or thermal radiation. In the P-LOFC case, the main concern shifts to the tops of the core and vessel, which become the hottest, rather than the coolest, areas. While no phenomena were given (H, L) rankings, several concerns rated (H, M) related to the convection and radiation heating of the upper vessel area, which is the basis for the design of the special insulation inside the top head.</p>
<p>A.8 <i>GFR accident scenarios and natural circulation</i></p>	<p>A GFR specificity is the lack of thermal inertia of the primary system, combined with the pressurised gas and the associated risk of leak. On a thermal-hydraulic point of view P-LOFC and D-LOFC are two main categories of transient that strongly influence the design of the system. Safety of the reactor mainly relies on active systems, and progression of a transient depends on the characteristics of several critical components, that are stimulated under conditions that are far from the normal ones in terms of pressure and temperature. Two aspects are important to look at.</p> <p>Decay heat removal emergency systems are based on forced gas circulation through the core. Nevertheless, for P-LOFC situations, where pressure remains high in the primary circuit, or on the longer term where heat has sufficiently decayed, natural circulation of the gas is possible. Several problems arise in that case: starting the natural circulation, cooling of the core by natural circulation through several decay heat removal loops (circulation can go directly from one loop to another one), pressure drop in the components (circulators, heat exchangers).</p> <p>In GFRs, modifications of the core geometry, for instance arising from a seismic event or from the pressure wave caused by a depressurization transient, may increase the reactivity and hence the core power. Water ingress in accidental conditions may also result in a GFR reactivity increase.</p>

Safety issues	Description
<p>A.9 <i>GFR behaviour of critical components</i></p>	<p>Technology using helium gas needs specific components compared to heavier gas like air. For instance a compressor in helium has a special design due to the properties of helium. And for emergency operation, one needs to adapt the present state of the art of compressors to define a design compatible with operating conditions from high pressure (i.e. 7 MPa) to low pressure (i.e. 0.5 MPa even lower) conditions. Another example is the thermal shielding which must support high-temperature and severe depressurization at the outlet of the core in case of a large leak on the cold duct.</p> <p>Finally, specific effects in accident conditions are expected that impact on the design of sub-systems. During severe transients due to a large leak, one can predict thermal and dynamical impact of the hot gas coming from the primary circuit on the wall of the close guard containment that surrounds the primary circuit. Or as noted above, flow reversal in the core can occur in some severe situations where pressure is low, or during depressurisation.</p>
<p>A.10 <i>Nuclear data on specific GFR materials and spectrum conditions</i></p>	<p>Nuclear data for core physics on specific GFR materials (carbide, helium, neutron absorber metals, and high content of minor actinides) and spectrum conditions (slight softening of the fast neutron spectrum due to presence of carbon) would benefit from a new cross-section library to decrease discrepancy with experimental values obtained in critical mock-ups. Some specific GFR effects are foreseen that need experimental evaluations: neutron streaming in gas channel, use of new reflector materials as Zr_3Si_2.</p>

3.2.B.1 Fission product transport

This subsection identifies and covers safety-relevant phenomena associated with the transport of fission products in an accident scenario such as a depressurisation of the primary system. The phenomena were ranked in a way that can be used to help guide safety assessments. The fission product transport (FPT) phenomena are often closely related with various Accidents and Thermal Fluids (ATF) areas. Significant phenomena are identified and ranked and the knowledge base, as well as the ability to model fission product transport, is assessed.

Depending on the design of a confinement or containment, the impact of a primary system pressure boundary breach can be minimized if fission product attenuation factors can be introduced into the release path. A host of material properties, thermal fluid states, and physics models must be collected, defined, and understood to evaluate such attenuation factors. Because of the small allowable releases during a depressurization from this reactor type (into a vented confinement), dust and aerosol issues are important to quantify even though the amounts of fission products involved may be modest (compared to potential aerosol generation in a severe LWR accident). The initial fission product contamination of the reactor circuit is of great importance because the most powerful driving force, helium pressure, will most likely act during the earliest stages of the accident. If an air ingress accident occurs with an unimpeded flow path, larger fission product releases can occur later in the accident.

Another issue of importance is the approach to modelling graphite properties. This issue impacts how data collection for the models is approached. Briefly, one approach is basic physics in nature, and the other is more empirical. The basic physics approach would have the advantage that measured graphite and fission product properties can be related to transport over a wide range of situations, but the physics may be very challenging. The empirical approach offers less theoretical complexity but may be limited by the cost of experiments and the range of accidents that can be covered. In any event, this issue would have to be resolved by a review of the state of the art in graphite and transport theory and would be influenced by the specific safety approaches taken by the reactor designers.

Finally, a significant phenomenon that may have not been explored in the past is the effect of mechanical shock and vibration in a D-LOFC on the transport and re-entrainment of dust and spalled-off oxide flakes. A failure of a large pipe would generate large mechanical forces (vibration, shocks, and pipe whip), and the resulting flow can generate a large amount of acoustic energy, both of which can launch dust and small particles into the existing gas flow as well as cause additional failures. Much of the literature is concerned with changes in temperature and flow velocity during an accident, but these impulsive and vibratory mechanical effects should also be considered, especially if the reactor internal surfaces are required to retain fission products during an accident to meet safety requirements. The internal surfaces will then take on many of the qualities of a safety system since they will have the formal function of retaining fission products during the course of an accident.

Scenarios that would significantly impact the release of fission products include: (1) large and small pressure boundary breaches which are assumed to have the potential to release not only the material entrained in the gas during normal operation but also material such as dust and fission products on metal surfaces; and (2) releases from the cleanup and holdup systems, which are only vaguely defined at the present time. Implicit in the needs of the FPT transport analysis are the models for determination of the fission product distribution in the core and reactor circuit during normal operating conditions since this is the starting point for the accident (and of course is very design specific). Simulation of the accident may require the addition of dust entrainment models and chemical reaction models. Below is a description of the analysed accident scenarios:

- P-LOFC fission product transport:
The major concern with the P-LOFC is how it may change the distribution of fission products prior to a pressure boundary breach since the event itself does not release fission products to the confinement. If the event results in a pressure relief valve opening, with or without sticking, a fission-product transport path will be generated. This path is design specific since a filter may be incorporated into the exhaust circuit.
- D-LOFC-fission product transport:
This event impacts FPT in two phases. The first phase is the initial depressurisation which releases fission products from the primary circuit via the blow-down/depressurization, any system vibrations, and source term entrainment by the discharge flow. This can be very important since some conceptual reactor building designs do not include a provision for filtering this rapid high-volume flow. Combustion of dust may add heat and more completely distribute the fission products in the confinement volume. The second phase occurs after the depressurisation and the heat-up of the core and reactor system. The higher temperatures can cause the redistribution of fission products (and perhaps some limited fuel failure, depending on the design margins and quality of the fuel). However, the driving force for the release of fission products to the environment is only the very weak thermal expansion of the gas. In addition, at this point in the accident, the building filters are expected to be operational in most designs.
- D-LOFC-with air and water ingress:
The more extreme version of the D-LOFC accident is the significant and continued flow of air into the core, which is only possible with a major reactor building and reactor system fault that establishes a convective air path between the reactor vessel and the environment. In this case, high fuel temperatures are possible, high fission product release is unlikely but possible, and a convective path is available for the transport of material out of the building. Three mechanisms are then available for the enhancement of fission product release and transport: (1) locally increased temperatures due to graphite oxidation which can drive the movement of the volatile fission products such as cesium and potentially increase the amount of failed fuel and subsequent fuel releases; (2) the destruction of the graphite and matrix

material which can release the trapped fission products that can be carried along with the flow as particles, vapour, or aerosols; and (3) the increased oxygen potential of the reactor environment which may change the chemical forms of the fission products and surfaces with which they interact.

Graphite oxidation with core consumption (and possible partial or total collapse) is a complex process highly dependent on the particular design, structural materials, accident scenario, and the design safety margins. The key features are the flow path, the temperatures, and the amount of oxidizer available. The free flow of the oxidizer may need to be stopped early in the accident to prevent serious fission product releases from the core.

The safety issues identified in this area are basically the same for both HTR and GFR systems (except for graphite-related aspect which are relevant only for HTRs).

3.2.B.2 Description of safety issues in the fission product transport area

Listed below are phenomena of particular significance because of their high importance and low knowledge level rankings. The first three phenomena (1 through 3) listed below are related to fuel, graphite and core materials; and they are significant because of their effect on releases from graphite in fuel form. Because of the small allowable releases during a depressurisation from this reactor type, dust and aerosol issues are important to quantify even though the amounts of fission products involved may be modest. The next four phenomena (4 through 7) listed below are related to primary coolant system, reactor coolant system, cavity, and confinement; and they are significant because of their effect on potential releases into primary system and to confinement.

Issues	Description
<i>B.1 Matrix permeability</i>	The permeability of the matrix is important when modelling FPT in a mechanistic manner, as the matrix functions as FP holdup barrier for less volatile FPs (both in fuel form and as dust). Some form of fairly comprehensive model over the conditions of interest is needed. Matrix permeability affects FP dust modelling as well, especially important in a PBR.
<i>B.2 FP transport through matrix</i>	Once through the particle, the matrix is the first barrier (note that pebbles are largely matrix). It also collects FPs as dust. Effective release rate coefficient (empirical constant) as an alternative to first principles may be more tractable. Matrix holdup can be important for the less volatile FPs. Dust in the PBR may be largely composed of matrix, so this issue will affect dust FP modelling as well.
<i>B.3 FP speciation in carbonatious material</i>	The chemical form of the FPs in the graphite and matrix material affects transport and hold up under both initial conditions and accidents. There is uncertain and/or incomplete information in this area. The temperature of the material will affect this behaviour. Understanding the chemical forms is important because they strongly influence transport.
<i>B.4 Aerosol growth</i>	This phenomenon can also have an impact on potential dose to control room and off-site locations. Low aerosol concentration and a dry environment can result in the growth of particles with high shapes factors and unusual size distributions. This has not been studied previously, and results need to be determined to assess the impact. Vented confinement makes even small aerosol concentrations important.

Issues	Description
<i>B.5 Resuspension</i>	This phenomenon can also have an impact on potential dose to control room and off-site locations. Since the actual FP content of the gas is expected to be low, the FPs that can be released from the surfaces of components becomes important. Past analyses have often focused on flow-induced lift-off of oxide layers and dust, but mechanical- shock and vibration-induced lift-off can be major drivers as well. Mechanical shocks/forces/vibrations can release FPs from pipe surface layers/films during accidents. There is a lack of data and models for anticipated conditions, especially mechanically induced ones.
<i>B.6 FP diffusivity and sorption in non-graphite surfaces</i>	These factors determine FP location during normal operation and act as traps during transient conditions. It can impact operation and maintenance (O&M) as well as accident doses. Past work has examined some metals, but little information may be available for the materials and temperatures of interest. These factors could be sensitive to the surface oxidation state. This information is needed in order to model the reactor circuit.
<i>B.7 Ag-110m generation, transport</i>	Both Ag (and Cs) can drive a significant O&M dose on power conversion and heat exchanger equipment. The potential for deposition on turbine blades for direct-cycle gas-turbine balance of plant (BOP) is a maintenance or worker dose concern. Silver is released from intact SiC TRISO particles by a yet-to-be-understood mechanism, primarily at very high operating temperatures and high burnup rates. The problem is likely to be greater for plutonium-bearing fuel, since the silver generation from plutonium fissions is ~50 times greater than that for uranium fissions. This transport mechanism is not well understood and there is limited data. Ag may alloy with metal components and make decontamination difficult; which may possibly result in a large impact on maintenance shielding.

3.2.C.1 High-temperature metallic materials

This subsection covers conventional material properties such as strength, creep, and fatigue as well as the associated aging in a potential 60-year lifetime for some of the plant components. The service conditions considered covers a range that included both chemical attack and thermal cycling; they also encompass irradiated material properties for metallic and non-metallic components in or near the core and the primary system. The maintenance of adequate safety margins over time is the major concern.

Phenomena evaluations are made considering these differences and their impacts on core components. Phenomena identification focused on material strength, ductility, toughness, effects of radiation, material compatibility with the coolants (and associated impurities), material thickness, and joining methods. Key components considered include the low alloy steel for the reactor pressure vessel and piping, core barrel, and various components of the turbo-machinery. Creep-fatigue properties are also of concern, as well as the aspects of flaw assessment and crack propagation.

The HTR design requires the use of a secondary loop process heat application and perhaps for electric power generation as well. The IHX's thin internal sections must be able to withstand the stresses associated with thermal loading and pressure differences between the primary and secondary loops, which may be quite substantial. Additionally, since these sections must operate at the full exit temperature of the reactor, metallurgical stability and environmental resistance of the materials in anticipated impure helium coolant environments must be adequate for the anticipated lifetimes. Several IHX materials-related phenomena are of particular significance for potentially contributing to fission product release at the site boundary. These include crack initiation and propagation due to

creep crack growth, creep, creep-fatigue, and aging; the lack of experience with primary boundary design methodology for new IHX structures; manufacturing phenomena for new designs (including joining issues); and the ability to inspect and test new IHX designs.

Specific issues must be addressed for reactor pressure vessels (RPVs) that are too large for shop fabrication and transportation. Validated procedures for on-site welding, postweld heat treatment (PWHT), and inspections will be required for the materials of construction. For vessels using materials other than those typical of LWR construction required for operation at higher temperatures, confirmation of the ability to be fabricated (especially effects of forging size and the ability to be welded), and data on the effects of radiation will be needed. Several material-related phenomena for the RPV fabrication/operation are of particular significance for potentially contributing to fission product release at the site boundary. These include crack initiation and subcritical crack growth, field fabrication process control, and property control in heavy sections.

For the RPV, the surface emissivity is a parameter of significant interest since the ability to reject heat passively and adequately during certain transients in the HTR is dependent on radiation from the vessel to the RCCS. Ageing, fatigue and environmental degradation of insulation with a possibility for plugging coolant channels are also significant phenomena because of their potential impact on fuel temperatures and RPV integrity.

Most of the materials used in a GFR design are different from the one used presently in reactors under operation. The material for the vessel and for the primary circuit is expected to be the same as those used for the HTR (a 9 Cr as a reference). But as GFR transients are not the same as those of the HTR, some differences in conditions are expected. Structural material of the core internals will be subject to temperature transients that will need to be quantified. For all those materials, measurement of their mechanical properties under realistic GFR conditions is a key to ensure structural integrity during transients and to evaluate their effective lifetime.

3.2.C.2 Description of safety issues in the high-temperature metallic materials area

Listed below are phenomena of particular significance because of their high importance and low knowledge level rankings. The first four phenomena (1 through 4) listed below are related to the intermediate heat exchanger (IHX); and they can potentially result in compromising the integrity of the IHX, in a breach to the secondary system, and in contributing to fission product release at the site boundary.

The subsequent three phenomena (5 through 7) listed below are related to the RPV fabrication and operation; and they are of particular interest because they can potentially compromise the RPV integrity and contribute to fission product release at the site boundary. The last two phenomena (8 and 9) listed below are related to possible compromise of surface emissivity and environmental degradation of insulation within the RPV; and they are of particular significance because of their potential impact on passive heat rejection ability, on fuel temperatures, and on RPV integrity.

Issues	Description
<p><i>C.1 Crack initiation and propagation (due to creep crack growth, creep, creep-fatigue, aging, subcritical crack growth)</i></p>	<p>Environmental effects on subcritical crack growth, subject to impacts of design issues, particularly for thin sections must be addressed. Stresses on IHX (both thin and thick sections) can present challenges; thermal transients can jeopardize fracture toughness. Carbide redistribution as a function of thermal stress can change the through-thickness properties. Maintaining fracture toughness, microstructural control, and mechanical properties in through-thickness of heavy sections is of particular concern. More is known about Alloy 617 from HTR and industry usage than for Alloy 230 [11-12]. Both environment and creep play significant roles in initiation and cyclic crack growth rate of Alloys 617 and 230. Mechanistic models for predicting damage development and failure criteria for time-dependent phenomena may need to be developed to enable conservative extrapolation from short-term laboratory test data to long-term design life.</p>
<p><i>C.2 Primary boundary design methodology limitations for new structures (lack of experience)</i></p>	<p>Time-dependent design criteria for complex structures should be developed and verified by structural testing. ASME Code-approved simplified methods have not been proven and are not permitted for compact IHX components. For example, there is no experience for the complex shape IHX, nor for designing and operating high-temperature components in the (safety) class 1 environment.</p>
<p><i>C.3 Manufacturing phenomena (such as joining)</i></p>	<p>Compact heat exchanger (CHE) cores (if used) will require advanced machining, forming, and joining (e.g., diffusion bonding, brazing, etc.) methods that may impact component integrity. CHE versus traditional tube and shell concepts must be assessed. However, these phenomena are generic and extend beyond the compact HXs to all the very high-temperature HXs. Compact HXs have not been used in nuclear applications; the candidate alloys and their joining processes have not been adequately established in nonnuclear applications.</p>
<p><i>C.4 Inspection/testing phenomena</i></p>	<p>Traditional non destructive evaluation (NDE) methods will not work for CHEs because of geometrical constraints. Proof testing of some kind may be necessary, such as leak testing with a tracer. Pre-service testing will be difficult, and in-service testing will be even harder. Condition monitoring may be useful. Knowledge related to pre-operational testing, pre-service inspection, fitness for service, and issues with leak tests is very limited.</p>
<p><i>C.5 Crack initiation and subcritical crack growth (including Leak Before Break)</i></p>	<p>9Cr-1Mo steel (grade 91) must be assessed for phenomena due to transients and operationally induced thermal loading, pressure loading, residual stress, existing flaws (degradation of welds, cyclic loading, low-cycle fatigue). There is a limited database from fossil energy applications at these temperatures. Aging in helium (depending on impurities) will most likely be greater than in air. Aging in impure helium may perhaps depend on impurity type and content.</p>
<p><i>C.6 Field fabrication process control</i></p>	<p>Fabrication issues must address field fabrication because of the vessel size [including welding, post weld heat treatment (PWHT)], section thickness (especially with 9Cr-1Mo steel) and pre-service inspection]. Fossil energy experience indicates that caution needs to be taken. On-site nuclear vessel fabrication is unprecedented.</p>

Issues	Description
<p>C.7 <i>Property control in heavy sections</i></p>	<p>Heavy-section properties are difficult to obtain because of hardenability issues. Adequate large ingot metallurgy technology does not exist for 9Cr-1Mo steel. Maintaining fracture toughness, microstructural control, and mechanical properties in through-thickness of heavy sections, 9Cr materials must be maintained (concerns in utilities regarding P91, >3-in. piping heat treatment). Excess deformation may be noted because of the emphasis on minimizing changes in core geometry. There is very limited data for specimens over 3 to 4-in thick. The little data available for specimens from 300-mm thick forgings show thick section properties to be lower than those of thin sections.</p>
<p>C.8 <i>Compromise of emissivity due to loss of desired surface layer properties</i></p>	<p>To ensure passive safety, high emissivity on both the inside and outside surfaces of the RPV is required to limit core temperatures. Formation and control of surface layers must be considered under both helium and air environments. There are limited studies on stainless steel and on Alloy 508 that show potential for maintaining high emissivity. Some studies are currently being conducted on emissivity but not on materials of concern.</p>
<p>C.9 <i>Environmental and radiation degradation of insulation with a possibility for plugging coolant channels</i></p>	<p>Relatively low dose and exposure is expected, but LOFC can result in temperatures high enough to challenge stability of fibrous insulation such as Kaowool. Need to assess effects on microstructural stability and thermo-physical properties during irradiation and high-temperature exposure in impure helium. Limited commercial information available for conditions of interest.</p>

3.2.D.1 Graphite and ceramics

This subsection discusses the issues associated with the use of graphite and ceramic material for structural support and neutron moderation in the core, which will be exposed to a challenging environment including high-temperatures and a radiation field. The phenomena considered include FP release from (or through) the graphite, degradation of thermal conductivity, structural properties, annealing, dust generation, and the aspects of creep and strain. Oxidation is also a concern, both in steady-state and in accident conditions, and the kinetics of that reaction and the associated phenomena are identified and evaluated. These important material characteristics provide the basis for safety margins in the design, as well as being important phenomenological aspects that impact accident scenarios and consequences.

The graphite single crystal is highly anisotropic due to the nature of its bonding; this anisotropy is transferred to the filler coke particles and also to the crystalline regions converted by graphitization in the binder phase. Thus, the mechanical and physical properties of graphite vary within a billet due to texture introduced during forming and thermal processing. Moreover, there is a statistical variability in the properties between billets within the same lots, between lots, and between batches due to variations in raw materials, formulations, and processing conditions. Therefore, it is necessary to develop a statistical database of the properties for a given graphite grade. The variations in chemical properties will have implications for chemical attack, degradation, and decommissioning. It may be necessary to use probabilistic design approaches to capture the variability of graphite.

A significant challenge related to graphite for HTRs is that the previous graphite grade qualified for nuclear service are generally no longer available, and for the most part, the precursors from which these grades were manufactured no longer exist. The present understanding of graphite behaviour is not sufficiently developed to enable the existing database to be extrapolated to nuclear graphite grades currently available. Hence, it is necessary to qualify new grades of graphite for use in HTRs and, in doing so, gain a more robust understanding of irradiated graphite behaviour to ensure that new theories and models have a sound, in-depth, scientific basis. In addition, in-service inspection and assessment

techniques should be developed and validated to ensure the structural integrity of these structures. Thus, the designers and operators require data to inform design decisions and assessment of replacement needs and service life.

Due to the inherent variability in the physical, mechanical, and thermal properties of un-irradiated graphite within billets and lots, the associated phenomena are rated as high importance. In addition, the effects of reactor environment on the physical properties must be characterized when the graphite is qualified. Significant work is required to bring the existing graphite codes and standards to an acceptable condition. For instance, the proposed Section III Division 2, Subsection CE of the ASME Boiler and Pressure Vessel (B&PV) Code (Design Requirements for Graphite Core Supports) was issued for review and comment in 1992, but only limited action has been taken on it since then. In 2006, a Special Group was commissioned under Section III of the ASME B&PV Code Committee to develop it. The same situation exists in other countries.

Differential thermal strains occur in graphite components due to temperature gradients and local variation in the coefficient of thermal expansion (CTE). Irradiation-induced changes in CTE are understood to be related to changes in the oriented porosity in the graphite structure. Stress due to differential thermal strain and differential neutron-irradiation-induced dimensional changes would very quickly cause fractures in the graphite components if it were not for the relief of stress due to neutron-irradiation-induced creep. There is insufficient data available for the effect of creep strain on CTE in graphite. Moreover, none of the available data is for the grades being considered for future HTRs. Also, mechanical properties of graphite are known to change with neutron-irradiation; local differences in moduli, strength, and toughness must be accounted for in the design. Although data exists for the effect of neutron dose and temperature on the mechanical properties of graphite, there is insufficient data on the effects of creep strain on the mechanical properties, and none of the available data is for the grades being considered for future HTRs. The combination of these factors makes it difficult to determine the probability of local failure, graphite spalling, and possible blockage of a fuel-element coolant channel.

3.2.D.2 Description of safety issues in the graphite and ceramics area

Listed below are phenomena of particular significance due to their high importance and low knowledge level rankings. The first three phenomena (1 through 3) listed below are related to irradiation-induced change in properties; and they are significant because they can have an impact on thermal protection of adjacent components, as well as maintaining the ability to control reactivity, maintaining the coolant flow path, and preventing excessive mechanical load on the fuel. The next two phenomena (4 and 5) listed below are related to blockage in graphite components due to graphite failure/spalling. They are significant because they can have an impact on thermal protection of adjacent components, on maintaining the ability to control reactivity, and/or on maintaining the coolant flow path.

In a GFR context, the characterisation of ceramic materials is of particular importance in consideration of the combined high-temperature and high fast neutron flux conditions, which during service may result in material property degradation.

Issues	Description
<p><i>D.1 Irradiation-induced changes in CTE (including the effects of creep strain)</i></p>	<p>Differential thermal strains occur in graphite components due to temperature gradients and local variation in the CTE. Variations in the CTE are a function of the irradiation conditions (temperature and dose) and the irradiation induced creep strain. Irradiation-induced changes in CTE are understood to be related to changes in the oriented porosity in the graphite structure. The changes are observed to be different when graphite is placed under stress during irradiation. The direction and magnitude of the stress (and creep strain) affect the extent of the CTE change. Only limited data are available for the effect of creep strain on CTE in graphite, and none of this data is for the grades proposed for future HTRs. Micro-structural/mechanistic studies are required. This information is needed for input to irradiated graphite component stress analyses.</p>
<p><i>D.2 Irradiation-induced change in mechanical properties (e.g., strength, toughness)</i></p>	<p>The properties of graphite are known to change with neutron irradiation, the extent of which is a function of the neutron dose, irradiation temperature, and irradiation-induced creep strain. Differential changes in moduli, strength, and toughness must be accounted for in the design. Although data exist for the effect of neutron dose and temperature on the mechanical properties of graphite, there are few data on the effects of creep strain on the mechanical properties. Moreover, none of the available data is for the grades currently being considered for future HTRs. Micro-structural/mechanistic studies are required, in addition to the need for a better understanding of fracture processes. This information is needed for input to irradiated graphite component stress analyses; irradiation creep further complicates this issue.</p>
<p><i>D.3 Irradiation-induced creep (dimensional change under stress)</i></p>	<p>Stress due to differential thermal strain and differential irradiation-induced dimensional changes would very quickly cause fracture in the graphite components if it were not for the relief of stress due to irradiation-induced creep. The phenomena and mechanism of irradiation-induced creep in graphite are therefore of high importance. Currently there are no creep data for the graphite grades being proposed for use in future HTRs. However, creep at low dose follows a linear law that can be explained through a dislocation pinning/unpinning model due to Kelly and Foreman. Marked deviation from this law has been observed at intermediate neutron doses. The applicability of the law has been extended by taking into account changes in the pore structure that manifest themselves as changes in the CTE with creep strain. However, the current creep law breaks down at high-temperature, moderate-dose and moderate-temperature high-dose combinations. A new model for creep is needed that can account for the observed deviations from linearity or the creep strain rate with neutron dose. Existing and new models must be shown to be applicable to the currently proposed graphite grades. It is essential that irradiation creep is better understood; including mechanistic effects and effects of interaction with the CTE. New models are needed along with data on new graphite materials. This data is required for graphite finite-element method (FEM) stress analyses.</p>

Issues	Description
<p><i>D.4 Blockage of fuel element coolant channel due to graphite failure/spalling (debris generated from within the graphite core structures)</i></p>	<p>This phenomenon can affect the ability to maintain a coolant flow path. Significant uncertainty exists as to the stress state of any graphite component in the core. Moreover, the strength of the components changes with dose, temperature, and creep strain. The combination of these factors makes the probability of local failure, graphite spalling, and possible blockage of a fuel element coolant channel difficult to determine. The two possible initiating mechanisms are: (a) component failure due to internal or external component stresses, and (b) component failure due to very high irradiation and severe degradation of the graphite. Although the changes in properties of graphite have been studied for many years there are still data gaps that make whole core modelling very difficult. Generic graphite codes are available for the prediction of internal stresses in irradiated graphite components; however, they require validation. There are also whole-core models for component interaction; however, these are reactor specific and they will also require validation.</p>
<p><i>D.5 Blockage of coolant channel in reactivity control block due to graphite failure/spalling (debris from non-graphite components in RPV)</i></p>	<p>This phenomenon can have an impact on thermal protection of adjacent components and on maintaining the ability to control reactivity. Significant uncertainty exists as to the stress state of any graphite component in the core. Moreover, the strength of the component changes with dose, temperature, and creep strain. The combination of these factors makes the probability of local failure, graphite spalling, and possible blockage of a coolant channel in a reactivity control block difficult to determine.</p>
<p><i>D.6 Ceramic material properties (high-temperature and irradiation)</i></p>	<p>In GFRs during some anticipated severe conditions, the gas at the outlet of the core can reach more than 1 200°C and heat shielding using ceramic materials must be used to withstand this temperature for several minutes. Specific material and technology must be developed, and its adequate material properties under these conditions must be verified experimentally.</p>

3.2.E.1 Fuel

The fuel forms for GCRs are very different from those used in water cooled reactors. For instance, in HTRs, the TRISO-CPF is used, which is a spherical layered composite about 1 mm in diameter. It consists of a kernel of uranium dioxide surrounded by a porous graphite buffer layer. Surrounding the buffer layer are a layer of dense pyrolytic carbon, a SiC layer, and a dense outer pyrolytic carbon layer. These three isotropic layers are termed the TRISO coating. Thousands of these particles are combined with a matrix material and pressed into either spherical forms for pebble bed fuels or cylindrical or annular compacts for prismatic fuels. In GFRs, Composite Matrix Ceramics (CMC) clad fuel is used. In preparation for future design, safety review, and operation of GCRs, the significant features of TRISO-CPF or CMC clad design, manufacture, and operation, as well as behaviour during accidents should be fully understood. To achieve this goal, the phenomena associated with the life-cycle phases of GCR fuels were identified and ranked. The following six scenarios were considered when ranking the phenomena:

- manufacturing;
- operations;
- depressurised heat-up accident;
- reactivity accident;
- depressurisation accident with water ingress;
- depressurisation accident with air ingress.

TRISO-CPF and CMC fuels are complex fuel forms from the perspective of fission product modelling. The multiple layers, the chemical state of the fission products, the different mechanisms

responsible for gaseous and metallic fission product transport in each layer, and the projected high burnups and fast neutron fluences make the modelling of fission product transport challenging. Fission product transport in the kernel is complex. Important mechanisms include recoil, diffusion of fission products to grain boundaries, vaporisation, and transport through the interconnected porosity of the kernel to the surface of the kernel and chemical reaction at the boundary of the kernel. These processes are functions of burnup and temperature and thus change over the life of the fuel.

For TRISO-CPF the buffer layer plays a role in the coated particle from the perspective of fission product transport. Depending on the specific irradiation conditions, the nature of the shrinkage and densification of the buffer establishes the initial condition for fission product transport during irradiation and under accident conditions. The buffer is a porous carbon layer (with an initial density of about 50%) whose function is to serve as a void volume for fission gases and act a material to absorb fission recoils and swelling of the fuel kernel. Sometimes the buffer cracks because of tangential stresses developed under irradiation. Because of the high porosity of the layer, it has the lowest conductivity of any layer in the coated particle and thus the largest temperature drop. Depending on the power produced in the kernel, the temperature gradient in the buffer may cause thermal (or Soret) fission product diffusion in the layer.

The inner and outer pyrocarbon (PyC) layers are dense layered carbon structures. The goal during fabrication is to make the PyC as isotropic as possible during the deposition to ensure the best radiation stability of the layer, which is needed for particle integrity. Some data exist on effective diffusivities in the PyC layers. Measured values from BISO particles (without SiC) have been collected. The data suggest that a dense, intact PyC layer is a very good barrier to noble gas release with significant diffusional releases not observed until very high-temperatures are reached. The PyC layers do not provide significant barriers to release of cesium, silver and strontium metallic fission products under normal or accident conditions. The mechanism responsible for the transport of gaseous and metallic fission products in the PyC layer has not been the subject of significant worldwide study. The understanding of the mechanism responsible for noble gas transport in PyC is limited.

SiC in TRISO-CFP is a high-density polycrystalline beta-SiC. It is the major fission product barrier in the fuel. As with pyrocarbon layers data on the effective diffusion coefficients of noble gases, cesium, strontium and silver have been inferred from integral release measurements. Fission product transport in failed fuel particles is expected to be a major contributor to the gas reactor source term. Fission product release from uranium contamination in the fuel element matrix (compact or sphere) as well as from particles with missing layers may also be significant contributors. The transport model depends on the half-life of the fission product and whether it is metallic or gaseous. There is a wide range of parameters that influence fission product transport in CPF. These include:

- Parameters on the macroscopic scale such as the bum-up of the particle, fast fluence (as surrogate for radiation damage), the temperature of the layer, and the partial pressure of a gas or vapour.
- Microscopic parameters related to the structure of the material such as the porosity and tortuosity of the porous medium, and the grain boundary microstructure.
- Parameters related to the chemical speciation of the fission products of interest including the stoichiometry of the fuel and its changes during normal and accident conditions, thermochemical data such as free energies of formation, vapour pressures and adsorption isotherms, and transport properties such as binary gas phase diffusivities and heats of transport.
- Physical parameters that result in multidimensional and multi-component effects including segregation and concentration of fission products as a result of cracking.
- Azimuthal temperature gradients.

To include all of these factors in all the six phenomena identification and ranking areas was judged to be somewhat excessive given our state of knowledge about the importance and knowledge levels of some of the more detailed factors. As a result, a few higher level factors were identified by the PIRT panel members to account for most of the individual factors. These higher level factors, listed below, were applied to each of the appropriate layers of the fuel from the kernel out to the fuel element (matrix materials).

- Condensed phase diffusion – Transport of condensable fission products by intergranular diffusion and/or intra-granular solid-state diffusion (grain boundary and/or bulk diffusion).
- Gas phase diffusion – Diffusion of gaseous fission products through layer (Knudsen and bulk diffusion through pore structure, and pressure driven permeation through structure including such factors such as holdup, cracking, adsorption, site poisoning, permeability, sintering, annealing).
- Thermodynamics of fission product-SiC system – Chemical form of fission products including the effects of solubility, intermetallics, and chemical activity.
- Intercalation – Trapping of species between sheets of the graphite structure.
- Trapping – Adsorption of fission products on defects.
- Fission product release through failures, e.g., cracking – Passage of fission gas products from the buffer region through regions in the SiC layer that fail during operation or an accident.

In a GFR, the clad thermal and mechanical properties are important, including thermal conductivity, heat capacity, permeability, ultimate stress, failure strain, Young's modulus, but also chemical interaction with carbide fuel, abrasion from helium high velocity flow, ageing due to fast neutron fluence. As composite ceramic is not a homogeneous material, most of the properties should be measured in different directions. The operating temperature of the clad is ranging from 400°C to 1 000°C. During transient, the clad temperature does not exceed 1 600°C.

3.2.E.2 Description of safety issues in the fuel area

The identified phenomena were aggregated for each component of the TRISO-CPF, i.e., kernel, buffer layer, inner pyrolytic carbon (IPyC) layer, SiC layer, outer pyrolytic carbon (OPyC) layer, and fuel element. Phenomena with importance rankings of High in three or more of the scenarios (manufacturing; operations; depressurised heat-up accident; reactivity accident; depressurisation accident with water ingress; and depressurisation accident with air ingress) are described below:

- Temperature related phenomena in the kernel, i.e., maximum fuel temperature and temperature versus time transient conditions, were judged to be important. The knowledge level was judged to be High. These two factors do not require additional research efforts.
- The thermodynamic state of the fission products in the kernel was judged to be important for each of the four accident conditions considered. The knowledge level was judged to be Medium. This phenomenon may require additional research for the water- and air-ingress accidents.
- The knowledge level for cracking of the IPyC layer was judged by to be in the Low or Mid-range. Research is needed to achieve better understanding of this phenomenon.
- The knowledge level for gas phase diffusion through the IPyC layer was judged to be Medium. This phenomenon may require additional research.

The following two issues have been identified as GFR-specific:

- High-temperature behaviour of ceramic fuel element, including degradation modes.
- Mechanical behaviour of fuel element and assembly.

Issues	Description
<i>E.1 Inner PyC Layer – Cracking</i>	Lengths, widths and numbers of cracks produced in IPyC layer during an accident can have a significant impact. These cracks in IPyC layer can lead to stress concentrations in the SiC layer high enough to cause failure of that layer. Gases will be released if the other layers have failed. Aggregate high importance and low to medium knowledge level rankings especially in the areas of operations, depressurised heat-up accident, depressurisation accident with water ingress, and depressurisation accident with air ingress. Increased knowledge level is needed.
<i>E.2 Kernel – Thermodynamic state of fission products</i>	The diffusivity of fission products is strongly influenced by their chemical form. Aggregate high importance and upper medium knowledge level rankings. Important for each of the four accident conditions considered (depressurised heat-up accident; reactivity accident; depressurisation accident with water ingress; and depressurization accident with air ingress). It may require additional research for the water- and air-ingress accidents, especially if they are to be included among the events considered within the licensing basis or as a severe core damage accident.
<i>E.3 Inner PyC Layer – Gas phase diffusion</i>	Gaseous fission products are generally retained by the IPyC, but metallics transport is high. High local accident temperatures could increase the diffusion rate. High importance and medium knowledge level rankings mainly in the areas of operations, depressurised heat-up accident, reactivity accident, and depressurisation accident with air ingress. It may require additional research.
<i>E.4 High-temperature behaviour of GFR ceramic fuel element including degradation modes</i>	The reference GFR fuel element is presently a carbide fuel clad with a composite matrix ceramic. Due to those innovative materials, a large program of properties measurements is foreseen to obtain thermal and mechanical characteristics on fresh and irradiated samples. During transient, the fuel temperature must not exceed melting (or vaporisation) temperature. One specific aspect of the GFR fuel element is its ability to support very high-temperatures. Presently two threshold temperatures have been set up. Up to 1 600°C the fuel element must keep its operating properties (during a limited time period) and mainly its capability to retain fission products. This gives a margin of around 400°C from the operating clad temperature. The reactor is designed to respect this limit on all operating transient. The second temperature threshold is examined in the “severe accidents” technical area. Up to the 1 600°C threshold, one must verify that the clad keeps its properties of first barrier, during a time period of some hours. Measurements of fuel and clad properties at high-temperature are thus expected. They need special equipment able to operate at that temperature, and also with irradiated samples. Experiments must adjust and control oxygen concentration in the environment because SiC oxidation is one of its main factors of loss of properties. There is a second temperature threshold set around 2 000°C (for some tens of minutes). This threshold gives an extra margin to core failure. The fuel element must keep its geometry up to this threshold. This allows the core to be cooled down up to this temperature. A specific experimental programme is needed to verify the good behaviour of the fuel around 2 000°C. Due to the lack of irradiated samples this program will be run on fresh fuel in a first step, but it could be completed with measurement, in a hot lab, of gas release from irradiated fuel pellets. One difficulty is the measurement at that temperature.

Issues	Description
<i>E.4 (Cont'd) High-temperature behaviour of GFR ceramic fuel element including degradation modes</i>	In order to understand the phenomenology of severe accidents for a GFR core, the mode of degradation of a ceramic clad and a carbide fuel should be tested. This will give input data for severe accidents analysis. One major difficulty is that core possible degradation could be very different from the one studied in a PWR or in a sodium fast reactor. For instance no clad melting is expected, but presently one cannot predict the conditions and the way a SiC/SiC clad collapses. Analytical experiments on fresh samples in specific facilities that can operate above 2 000°C are proposed. They will be necessary to start expertise of the core degradation phenomenology and possible calculations with severe accidents codes.
<i>E.5 Mechanical behaviour of fuel element and assembly in a GFR</i>	The mechanical behaviour of both the fuel element and the fuel sub-assembly is important to manage the risk of clad failure under operation. For the fuel element, effect of gaseous fission product release that pressurises the clad is a key factor, together with the modification of the conductivity of the clad-pellet gas gap (that generally induces an increase of the fuel temperature). For the fuel assembly, mechanical behaviour in operation (vibration, bending) or during transportation (shock, handling) is needed to qualify the fuel element.

3.3 Facilities vs. issues

A. Accident and thermal fluids

Issue A.1: Core coolant bypass flow

Facility (Institution)	Availability	Capabilities
HE-FUS3 (ENEA)	In operation for FUSION techn., if free can be used for GCR	The loop allows simulating LOCA, LOFA, power excursion, long term isothermal cooling flow, slow thermal cycling flow and fast cold thermal shock flow.
HTTR (JAEA)	Operating, available	Estimated by reactor thermal power, heat removal of vessel cooling system, coolant flow rate, coolant temperatures at upper and lower plenum, temperature of core internals, etc at normal operation.
Integral facility (OSU and INL)	Proposed, in design phase	In addition to coolant bypass flow, it could also be used to measure outlet plenum and gravity-driven flow distributions.

Issue A.2: Power/flux profiles in PBRs

Facility (Institution)	Availability	Capabilities
ACRR (SNL)	Available, operational	It could be used to perform TRISO fuel transient testing for abnormal and/or accident conditions and to study transient behaviour of gas reactor fuels. It can produce realistic power ramps and simulate various RIA scenarios.

Issue A.3: Outlet plenum flows

Facility (Institution)	Availability	Capabilities
HTTR (JAEA)	Operating	Estimated by coolant temperature at reactor outlet. Symmetrically-placed two couples of thermocouples are installed inside inner pipe in the concentric hot gas duct.

MIR (INL)	Available, operational	Matched index of refraction (MIR) facility provides detailed information on turbulent flow, mixing in a small scale, unheated outlet plenum. Data can be used for CFD validation.
Integral facility (OSU and INL)	Proposed	See (A.1) above
Modified NSTF (ANL)	Available, under modification	It is being modified to obtain data for the gas reactor vessel/reactor cavity passive cooling systems such as the RCCS proposed for both the pebble-bed and prismatic designs. Heater heat fluxes can reach 23kW/m ² and operating temperatures can reach 677°C.

Issue A.4: Reactivity-temperature feedback coefficients

Facility (Institution)	Availability	Capabilities
HTTR (JAEA)	Operating, available	Temperature coefficients measurement test, and reactivity insertion test as a parameter of power level.
Modified NSTF (ANL)	Available, under modification	See (A.3) above

Issue A.5: Emissivity aspects for the vessel and reactor cavity cooling system

Facility (Institution)	Availability	Capabilities
HTTR (JAEA)	Operating, available	Estimated by temperatures of reactor pressure vessel (RPV) and panel of vessel cooling system during normal operation, loss of forced cooling test and vessel cooling system stop test
Modified NSTF (ANL)	Available, under modification	See (A.3) above

Issue A.6: Reactor vessel cavity air circulation and heat transfer

Facility (Institution)	Availability	Capabilities
A2 (FZK)	Refurbished	Containment simulator, 1 MPa, 220m ³ . Ready to investigate the behaviour of graphite dust in air
HELOKA-HP/-LP (FZK)	Under construct. for FUSION	Helium: 8 MPa, Mass flow rate: 1.4 kg/s HELOKA-LP: Helium, Air: 0,6 MPa
L-STAR (FZK)	Available for GFR TH and dust particle removal	Air, CO ₂ , N ₂ : 0.3 MPa Unheated/heated test section Small loop: Re ~ 50000, T max ~ 200°C Large loop (L-STAR): Re ~ 200000, T max ~ 700°C
HTTR (JAEA)	Operating, available	Estimated by temperatures of RPV and panel of vessel cooling system in normal operation, loss of forced cooling and vessel cooling system stop test
Integral facility (OSU and INL)	Proposed	See (A.1) above
RCCS separate effects facility (ANL)	Planned	Separate effects issues include reactor cavity heat transfer and natural convection, heat transfer in specific water stand-pipe or air duct geometry, natural convection flow transition and stability in parallel channel networks, two-phase mixture flashing and subcooled boiling behaviour in networks, and two-phase separation in storage tanks. The results could be made available for CFD and system code validation efforts.

Modified NSTF (ANL)	Available, under modification	See (A.3) above
S-HT2 facility (UC-Berkeley)	Available, operational	Operated at reduced temperature, pressure and power using simulant fluids (nitrogen and heat transfer oil).

Issue A.7: Convection/radiation heating of upper vessel area

Facility (Institution)	Availability	Capabilities
HEBLO (FZK)	Operating for FUSION techn.	Helium, 8 MPa; T < 450 °C; Mass flow rate: 120 g/s Test section ~ 1m ³ available Some free slots for experiments available on demand.
A2 (FZK)	Refurbished	See (A6) above
HELOKA-HP/-LP (FZK)	Under construction for FUSION	See (A6) above
ITHEX (FZK)	In operation for FUSION techn. available 2011	Heat transfer and turbulent fluid flow measurements for CFD qualification: Fluid: various Slab geometry with Re ~ 30000.
NACOK (FZJ)	unclear	(Natural core flow with corrosion) Designed to study accidental air ingress and validated codes.
HE-FUS3 (ENEA)	In operation for FUSION techn.	See (A1) above
HTTR (JAEA)	Operating, available	Temperatures are measured during the loss of forced cooling test. Thermocouples are installed in core internals as well as upper part of RPV.
RCCS separate effects facility (ANL)	Planned	See (A.6) above
Modified NSTF (ANL)	Available, under modification	See (A.3) above

Issue A.8: GFR accident scenarios and natural circulation

Facility (Institution)	Availability	Capabilities
SALSA (CEA)	Being manufactured	SALSA is an air loop representing a reduce scale (1/3) of ALLEGRO which is the GFR demonstrator. It was designed using Re and Ri similitude rules, simulating the operation of a GFR with its 3 DHR loops, in order to validate the CATHARE code.
ESTHAIR (CEA)	Available, operational	ESTHAIR is an air cooled low pressure and temperature experimental set up which can perform hydraulic studies on a representative fuel core mocks up in order to determine heat exchange and friction correlations and also the velocity and pressure maps at the inlet and the outlet of the mocks up.
L-STAR (FZK)	Available for GFR TH and dust particle removal	See (A6) above
REKO (FZJ)	Available	Small-scale facilities to study possible hydrogen release in GCR after water ingress.

Issue A.9: GFR, behaviour of critical components

Facility (Institution)	Availability	Capabilities
HECO (CEA)	Being manufactured	Helium loop representative of ALLEGRO conditions in helium, in case of forced convection strategy in LOCA conditions.

HETHIMO (CEA)	Available	Used to qualify thermal shielding for pipes or cross duct. Helium up to 100 bar and 1 000°C.
HELAN (CEA)	Being manufactured	Used for the core barrel thermal conditions. Helium at low pressure and a temperature up to 1 250°C.
HEDYT (CEA)	Available	Used for component qualification. It can reach 850°C at 80 bar with a helium flow rate of 50 g/s
HETIQ (CEA)	Available	Used to qualify high-temperature static seals, at relevant GFR conditions (He up to 100 bar and 1 000°C)
ESTHEL (CEA)	Conceptual design	To study thermal radiation effect in heat transfer. Planned to be installed in the HEDYT loop

Issue A.10: Nuclear data on specific GFR materials and spectrum conditions

Facility (Institution)	Availability	Capabilities
ENIGMA (CEA)	Being refurbished, available in 2011	ENIGMA is a programme on prototypic GFR materials in the zero power reactor MASURCA, dedicated to the neutronic studies of fast reactor lattices. The adaptability of the MASURCA core allows the validation of innovative core designs.

B. Fission Product Transport

Issue B.1: Matrix permeability

Facility (Institution)	Availability	Capabilities
HTTR (JAEA)	Operating, available, available from after refuelling	Matrix permeability can be examined by HTTR operation and PIEs. During HTTR operation, gaseous fission products from the HTTR fuel, such as krypton and xenon isotopes, can be measured by primary coolant sampling tests. Fractional releases of gaseous FPs are evaluated by fission gas release model developed in JAEA. PIEs are also available from after refuelling of the HTTR 1 st loading fuel.
High temperature FP release facility (INL)	Under development	The furnace has a maximum temperature of 2 000°C and can accommodate fuel samples up to 6 cm in diameter. It possesses a water cooled cold finger; metal plates attached to the end of the cold finger act as fission product (e.g., ¹¹⁰ mAg, ¹³⁷ Cs, ⁹⁰ Sr, ¹⁵⁴ Eu) condensation surfaces.
ATR (INL)	Available, operational	Designed to evaluate the effects of intense neutron and gamma radiation on material samples, especially nuclear fuels. The ATR has large-volume, high-flux test locations for irradiation of fuel, reactor materials and components (th. n. flux up to 1.0×10^{15} n/cm ² s).

Issue B.2: FP transport through matrix

Facility (Institution)	Availability	Capabilities
THAI (Becker Techn.)	Available, operational	Graphite particle transport in gas flow; large scale, multi compartment vessel, max. 14 bar/ 180°C, He/N ₂ /H ₂ /Air gas mixtures
GPLoop (FZD)	Planned for 2010	Particle (graphite) transport in gas flow; small scale loop, max. 2 MPa, He/N ₂ gas mixture

HTTR (JAEA)	Operating, available during the HTTR annual maintenance and/or from after refuelling of the HTTR 1 st loading fuel.	FP transport through matrix can be evaluated by HTTR operation and PIE. The dust flowing in the primary circuit during the operation can be trapped by filters at primary coolant gas circulators located at primary pressurised water cooler (PPWC) and auxiliary cooling system (ACS) of the HTTR. The dust trapped by the filter can be examined in PIEs. PIE is to be carried out at JAEA Oarai.
High temperature FP release facility (INL)	Under development	See (B.1) above
ATR (INL)	Available, operational	See (B.1) above

Issue B.3: FP speciation in carbonatious material

Facility (Institution)	Availability	Capabilities
HTHL (NRI)	Available. In-pile from 2011	Helium, max: 7 MPa, 900°C, 10 m ³ /s, purification rate 5-10%, fast neutron flux 1×10 ¹⁴ n/cm ² s, space for samples 30×570 mm.
THAI (Becker Techn.)	Available, operational	See (B.2) above
HTTR (JAEA)	Operating, available, available in the fuel failure test to be planned after refuelling of the HTTR 1 st loading fuel.	FP speciation in carbonatious material can be evaluated by HTTR operation and PIE. During operation, gaseous FP from the HTTR fuel, such as krypton and xenon isotopes, can be measured by primary coolant sampling. Based on these data, FP transport mechanisms through fuel compact matrix can be studied by analytical techniques such as JAEA fission gas release model and fuel performance model. PIE can be performed at JAEA Oarai.
H. H. Uhlig corrosion laboratory (MIT)	Available, operational	The facilities in this laboratory can be used for the study of diffusion and chemical reactions in fuel materials at temperatures up to 1 800°C.
High temperature FP release facility (INL)		See (B.1) above

Issue B.4: Aerosol growth

Facility (Institution)	Availability	Capabilities
HTHL (NRI)	Available. In-pile from 2011	See (B.3) above
THAI (Becker Techn.)	Available, operational	See (B.2) above
HTTR	Operating, available	Behaviour of aerosol and its dose in reactor building and off-site locations are measured during the HTTR operation. No serious release of aerosols have been found during the rise-to-power tests and the past service operation. Service operation such as long-term operation at outlet gas coolant temperature of 850/950°C of the HTTR will be available to investigate detailed aerosol behaviour
High temperature FP release facility (INL)	Under development	See (B.1) above

Issue B.5: Resuspension

Facility (Institution)	Availability	Capabilities
THAI (Becker Techn.)	Available, operational	See (B.2) above
HTTR (JAEA)	Operating, available, available from after refuelling.	Resuspension of FPs from metallic component can be examined by HTTR PIE. Dust with FPs flowing in the primary coolant is trapped by the dust filters (made with SUS) of primary coolant gas circulators located at PPWC and ACS of the HTTR. These filters are exchanged periodically during the maintenance period. The filter and/or dust trapped can be examined in PIEs.
High temperature FP release facility (INL)	Under development	See (B.1) above

Issue B.6: FP diffusivity and sorption in non-graphite surfaces

Facility (Institution)	Availability	Capabilities
MERARG (CEA)	Available, operational	It is an oven heated by induced current, located in a hot cell and which is coupled to an on line measurement system of gas released from a fuel sample. Can be used for FP plate out and agglomeration in Helium. It has so far been used to investigate the fission gas release from various fuels.
THAI (Becker Techn.)	Available, operational	See (B.2) above
HTTR	Planned for fuel failure test, also available by using the dust filters (made with SUS)	Plate-out probes will be settled at primary coolant pipes at certain locations such as reactor outlet/inlet, PPWC and ACS, etc. FPs flowing in the primary coolant is trapped by these probes. The probe can be examined in PIEs. PIEs are available during the HTTR annual maintenance and/or from after refuelling of the HTTR 1 st loading fuel.
High temperature furnace (MIT)	Available, operational	See (B.3) above
High temperature FP release facility (INL)	Under development	See (B.1) above

Issue B.7: Ag-110m generation, transport

Facility (Institution)	Availability	Capabilities
HTHL (NRI)	Available. In-pile from 2011	See (B.3) above
High temperature FP release facility (INL)	Under development	See (B.1) above
ATR (INL)	Available, operational	See (B.1) above

C. High-temperature metallic materials

Issue C.1: Crack initiation and propagation (due to creep crack growth, creep, creep-fatigue, aging, subcritical crack growth)

Facility (Institution)	Availability	Capabilities
HTHL (NRI)	Available for out -of-pile tests. In-pile from 2011	Helium, max: 7 MPa, 900°C, 10 m ³ /s, purification rate 5-10%, fast neutron flux 1×10 ¹⁴ n/cm ² s, space for samples 30×570 mm.
HTTL (INL)	Available, operational	It includes state-of-the-art high-temperature testing and examination equipment. In addition, several high-temperature (up to 3 000°C) furnaces are available for component testing.
High temp. mat. lab. (ORNL)	Available, operational	It includes a number of TEM, SEM, Auger, Atom Probe, etc. which are routinely used for irradiated materials.

Issue C.2: Primary boundary design methodology limitations for new structures (lack of experience)

Facility (Institution)	Availability	Capabilities
HTTL (INL)	Available, operational	See (C.1) above
High temp. mat. lab. (ORNL)	Available, operational	See (C.1) above

Issue C.3: Manufacturing phenomena (such as joining)

Facility (Institution)	Availability	Capabilities
High-Power-Laser-Lab (TUD)	Available, operational	Joining of ceramic materials (SiC, Si ₃ N ₄ , Al ₂ O ₃ , ZrO ₂)
HTTL (INL)	Available, operational	See (C.1) above
High temperature mat. lab. (ORNL)	Available, operational	See (C.1) above

Issue C.4: Inspection/testing phenomena

Facility (Institution)	Availability	Capabilities
High-Power-Laser-Lab (TUD)	Available, operational	See (C3) above
HTTR (JAEA)	Available for in- service inspect.	In-service inspection of heat transfer tubes of tube and shell type IHX (intermediate heat exchanger) for HTTR
HTTL (INL)	Available, operational	See (C.1) above
High temperature mat. lab. (ORNL)	Available, operational	See (C.1) above

Issue C.5: Crack initiation and subcritical crack growth

Facility (Institution)	Availability	Capabilities
HTHL (NRI)	Available. In-pile from 2011	See (C.1) above
DEDIFAR (CEA)	Available	DEDIFAR is a device used to correlate the crack size with a leakage flow rate. The objective is to validate models used in codes, with relevant crack geometry and relevant GFR conditions.
HTTL (INL)	Available, operational	See (C.1) above
High temperature mat. lab. (ORNL)	Available, operational	See (C.1) above

Issue C.6: Field fabrication process control

Facility (Institution)	Availability	Capabilities
High-Power-Laser-Lab (TUD)	Available, operational	See (C3) above
HTTL (INL)	Available, operational	See (C.1) above
High temperature mat. lab. (ORNL)	Available, operational	See (C.1) above

Issue C.7: Property control in heavy sections

Facility (Institution)	Availability	Capabilities
HTTL (INL)	Available, operational	See (C.1) above
High temperature mat. lab. (ORNL)	Available, operational	See (C.1) above

Issue C.8: Compromise of emissivity due to loss of desired surface layer properties

Facility (Institution)	Availability	Capabilities
HTTR (JAEA)	Operating, available	Emissivity of the HTTR RPV can be estimated by the loss of forced cooling test, and the loss of vessel cooling system test results. Data on changes in emissivity at normal rated operation can be obtained.
HTTL (INL)	Available, operational	See (C.1) above
High temperature mat. lab. (ORNL)	Available, operational	See (C.1) above

Issue C.9: Environmental and radiation degradation of insulation with a possibility for plugging coolant channels

Facility (Institution)	Availability	Capabilities
HTHL (NRI)	Available for out-of-pile tests. In-pile from 2011	See (C.1) above
Gas cooled reactor Test Tower facility (GA)	Available, operational	It has been used for GCR tests of control rods and drives, high-temperature thermal insulation, graphite bock integrity, core earthquake response, fuel handling equipment, and thermal/hydraulic tests.
HTTL (INL)	Available, operational	See (C.1) above
High temperature mat. lab. (ORNL)	Available, operational	See (C.1) above

D. Graphite and ceramics

Issue D.1: Irradiation-induced changes in CTE (including the effects of creep strain)

Facility (Institution)	Availability	Capabilities
HTHL (NRI)	Available for out-of-pile tests. In-pile from 2011	Helium, max: 7 MPa, 900°C, 10 m ³ /s, purification rate 5-10%, fast neutron flux 1×10 ¹⁴ n/cm ² s, space for samples 30×570 mm.
HTTR (JAEA)	Operating, available, available from after refuelling.	PIE of HTTR 1 st loading fuel block. Specimens of IG-110 graphite, PGX graphite and ASR-ORB carbon for CTE measurement are installed in the HTTR graphite blocks. CTE measurements will be carried out by taking out the specimens from blocks after the refuelling.
HFIR (ORNL)	Available, operational	It can be used to irradiate small specimens of gas reactor fuel and graphite in a high neutron flux environment (thermal fluxes close to 1.8×10 ¹⁵ n/cm ² s and fast neutron peak in the inner core centerline of 2.4×10 ¹⁵ n/cm ² s).
Research reactor and irradiation facilities (MIT)	Available, operational	MIT has a 5-MW research reactor and has extensive experience in the conduct of in-reactor experiments at high-temperature gas reactor conditions.

Issue D.2: Irradiation-induced change in mechanical properties (e.g., strength, toughness)

Facility (Institution)	Availability	Capabilities
HTHL (NRI)	Available for out-of-pile tests. In-pile from 2011	See (D.1) above
HTTR (JAEA)	Operating, available from after refuelling.	PIE of HTTR 1 st loading fuel block. Specimens of IG-110 graphite, PGX graphite and ASR-ORB carbon are installed in the HTTR graphite blocks. Dimensional change, bending strength, compressive strength, dynamic Young's modulus and thermal diffusivity will be measured. These measurements will be carried out by taking out the specimens from blocks after the refuelling.
HFIR (ORNL)	Available, operational	See (D.1) above
Research reactor and irradiation facilities (MIT)	Available, operational	See (D.1) above

Issue D.3: Irradiation-induced creep (dimensional change under stress)

Facility (Institution)	Availability	Capabilities
HTHL (NRI)	Available for out-of-pile tests. In-pile from 2011	See (D.1) above
HTTR (JAEA)	Operating, available from after refuelling.	PIE of HTTR 1 st loading fuel block. Fuel blocks have residual stress which is given by irradiation-induced creep effect on graphite. The stress will be released by cutting the block. The creep effect will be evaluated by the dimensions of graphite block before and after the cut. The irradiation database can be used for the creep effect evaluation as well.
HFIR (ORNL)	Available, operational	See (D.1) above
Research reactor and irradiation facilities (MIT)	Available, operational	See (D.1) above

Issue D.4: Blockage of fuel element coolant channel due to graphite failure/spalling

Facility (Institution)	Availability	Capabilities
GOLAB (FZJ)	Not specified	The GOLAB facility (Graphite Oxidation Lab) was designed for small-scale studies on phenomena related to oxidation behaviour of graphite and further innovative carbon based materials (CFC, SiC, composites, doped materials) in standard tests.
HTTR (JAEA)	Planned for fuel failure test.	Evaluation of FP transport by the fuel failure test simulating a blockage. Some of the coolant flow pass in the irradiation test blocks with fuels will be blocked by plugs. It simulates blockage of fuel element coolant channel due to graphite failure.
CCCTF (ORNL)	Available, operational	It contains a fully programmable furnace facility with special gas sampling features with temperatures up to 2 000°C.

Issue D.5: Blockage of coolant channel in reactivity control block due to graphite failure/spalling

Facility (Institution)	Availability	Capabilities
GOLAB (FZJ)	Not specified	See (D.4) above
CCCTF (ORNL)	Available, operational	See (D.4) above

Issue D.6: Ceramic cladding material properties (high temp. and irradiation)

Facility (Institution)	Availability	Capabilities
HTHL (NRI)	Available for out-of-pile tests. In-pile from 2011	See (D.1) above
GOLAB (FZJ)	Not specified	See (D.4) above
HT-Furnace (TUD)	Available in 2010	Corrosion tests of graphite and ceramics

E. Fuel

Issue E.1: Inner PyC Layer-Cracking

Facility (Institution)	Availability	Capabilities
HT-Furnace (TUD)	Available in 2010	Corrosion tests of graphite and ceramics
HTTR (JAEA)	Operating, available, available from after refuelling	It can be carried out by PIEs with HTTR 1 st loading fuel. Fuel compact samples are deconsolidated to coated fuel particle by electric deconsolidation – acid leaching test. Liquid sorption technique with methyl iodide to detect inner PyC cracking has been developed in JAEA. Out-of-pile heating in oxidized/non-oxidized condition can be carried out at JAEA.
NSRR (JAEA)	Operating, available	Pulse irradiation tests for reactivity insertion accident (RIA) studies, to obtain the threshold of fuel failure in terms of fuel enthalpy, burn up, fuel design, etc. A test with irradiated fuel had been performed. Experiments with fresh TRISO fuel particles and compacts are being performed, and to be extended for irradiated specimens.
CCCTF (ORNL)	Available, operational	It contains a fully programmable furnace facility with gas sampling features with temperature up to 2 000°C.

ACRR (SNL)	Available, operational	It could be used to perform TRISO fuel transient testing for abnormal and/or accident conditions and to study transient behaviour of gas reactor fuels. It can produce power ramps and RIA scenarios.
Research reactor and irradiation facilities (MIT)	Available, operational	MIT has a 5-MW research reactor and has extensive experience in the conduct of GCR experiments.

Issue E.2: Kernel - Thermodynamic state of fission products

Facility (Institution)	Availability	Capabilities
HTTR (JAEA)	Operating, available from after refuelling.	It can be carried out by PIEs of HTTR 1 st loading fuel. Out-of-pile heating tests under non-oxidized condition simulated for depressurised heat-up accident and reactivity accident, and under oxidized condition for depressurization accident with air ingress will be carried out at facilities in JAEA Oarai.
NSRR (JAEA)	Operating, available	See (E.1) above
TREAT (INL)	Shut down, can be restarted	The transient reactor test facility (TREAT) at INL was designed to test the behaviour of various fuels and structural materials under extreme or “transient” conditions, and now is in shutdown condition. It can be restarted if needed.
ACRR (SNL)	Available, operational	See (E.1) above
Research reactor and irradiation facilities (MIT)	Available, operational	See (E.1) above

Issue E.3: Inner PyC Layer - Gas phase diffusion

Facility (Institution)	Availability	Capabilities
HTTR (JAEA)	Operating, available from after refuelling	It can be carried out by PIE of HTTR 1 st loading fuel. Out-of-pile heating tests under non-oxidizing condition for depressurised heat-up accident and reactivity accident and oxidized condition for depressurization accident with air ingress will be carried out at JAEA.
NSRR (JAEA)	Operating, available	See (E.1) above
TREAT (INL)	Shut down, can be restarted	See (E.2) above
ACRR (SNL)	Available, operational	See (E.1) above
Research reactor and irradiation facilities (MIT)	Available, operational	See (E.1) above

Issue E.4: High-temperature behaviour of ceramic fuel element, incl. degradation

Facility (Institution)	Availability	Capabilities
HEDYT (CEA)	Available, operational	See (A9) above. HEDYT can also perform erosion tests of cladding materials
HT-Furnace (TUD)	Available in 2010	Corrosion tests of graphite and ceramics

Other CEA facilities for GFR studies

Facility (Institution)	Availability	Capabilities
PHEBUS, PLINIUS ALLEGRO	Operational Planned (2020)	Severe core damage and molten core behaviour GFR demonstration plant (available in ~2020)

4. SUMMARY AND RECOMMENDATIONS

4.1 Summary

The Task on Advanced Reactor Experimental Facilities (TAREF) was initiated based on discussions held by the OECD/NEA Committee on the Safety of the Nuclear Installations (CSNI) and the Committee on Nuclear Regulatory Activities (CNRA) during a joint Workshop on the Role of Research in a Regulatory Context (RRRC-2, June 2007). Among other topics, the Workshop addressed the challenges that the nuclear community will face when performing safety evaluations of advanced reactor designs, the research that may be needed to perform the reviews, and the possible means for jointly conducting this research. In particular, the Workshop discussed research topics relevant for GCRs and SFRs and recommended that CSNI organise a task group to identify the needed research and recommend a path forward.

CSNI initiated TAREF to provide an overview of facilities suitable for carrying out the safety research that was considered necessary for GCRs and SFRs. Other reactor systems could be considered in a subsequent phase.

The TAREF task was created in spring 2008, with the following group of participating countries:

Canada	China	Czech Republic	Finland	France	Germany
Hungary	Italy	Japan	Korea	United States	

The Group decided to build on the experience of a similar activity conducted by CSNI and described in the report entitled *Nuclear Safety Research in OECD Countries: Support Facilities for Existing and Advanced Reactors (SFEAR)*, which focused on facilities suitable for current and advanced water reactor systems. In particular, the SFEAR method was adopted, consisting of first identifying high priority safety issues that require research, and then categorising the available facilities in terms of their ability to address the safety issues.

At the first TAREF meeting, it was decided that the GCR-related task could be completed at an earlier stage than the SFR task, considering that a significant part of the safety items to be addressed had already been compiled in an earlier USNRC exercise (called the phenomenon identification and ranking tables – PIRT) [5,10]. Hence, for practical reasons, it was decided to produce two separate Task reports, i.e. the present one on GCRs and a following one on SFRs – the latter being scheduled for the end of 2010.

The TAREF Group followed an approach similar to the PIRT performed by the USNRC, and consistent with that approach, identified the following technical areas to be addressed:

- A. accident and thermal fluids (including neutronics);
- B. fission-product transport;
- C. high-temperature metallic materials;
- D. graphite and ceramics;
- E. fuel (Tristructural-isotropic (TRISO) and other fuel types).

In the case of structural materials, graphite and ceramics experience can be broader than nuclear and this experience was considered to the degree possible. Other technical areas such as seismic assessment (except for potential consequences on core compaction), fire safety, instrumentation and

control and human and organisational factors are not treated here, since the issues are not specific to GCRs.

For each of the above technical areas, the TAREF members identified the safety issues still needing research work. Only the issues identified as being of high safety relevance and for which the state of knowledge is low or medium were included in the discussions.

For each of the safety issues, the TAREF members identified the related facilities that were deemed appropriate to address the issue in question, providing relevant information such as operating conditions (in- or out-of-reactor), operating range, description of the test section, type of testing, instrumentation, current status and availability, uniqueness, etc.

Based on the information that was assembled on both safety issues and related facilities, the task members assessed prospects and priorities for GCR safety research and developed recommendations as to priorities and options for CSNI regarding facility utilisation through programmes that could be pursued internationally. In particular, the Group agreed on the main criteria for priority setting, which was based on the following items [High, Medium or Low (H, M, L) for each item]:

- a) relevance of the facility to cover a specific issue;
- b) uniqueness (e.g. one of a kind for in-pile testing);
- c) availability for a potential programme addressing the issue;
- d) readiness (e.g., staff available to run it);
- e) operating cost (<0.3, 0.3-1, >1M\$), or construction cost (<0.5, 0.5-2, >2M\$).

TAREF members that had proposed facilities were requested to characterise their proposed facilities in relation to the above criteria. Based on this, the Group recommendations for CSNI were developed.

4.2 Conclusions and recommendations

1. The TAREF task proved to be a useful exercise for gathering consensus on the technical areas and issues related to the safety of GCR systems, as well as for identifying a number of facilities that are or will become available in OECD member countries for supporting GCR safety research.
2. Existing facilities and facilities that are being constructed or planned in member countries cover all technical areas of concern and most of the safety issues identified in these areas. Hence, there is no apparent need for CSNI to build a facility (beyond what is currently planned in member countries).
3. Based on the responses received, the facilities that were among the most high ranked were identified. These facilities are shown in the following Table.

TAREF GCR Summary Ratings

	Accident and thermal fluids	Fission product transport	High-temperature materials	Graphite and ceramics	Fuel
Czech Republic		HTHL	HTHL	HTHL	
France (*)	HEDYT ENIGMA	MERARG		HEDYT	PLINIUS
Germany	HELOKA A2	THAI	High Power Laser Lab		
Italy	HE-FUS3				
Japan	HTTR	HTTR	HTTR		NSRR
USA		ATR	ORNL materials lab INL High Temp Test Lab	MIT Reactor HFIR	ACRR ATR MIT Reactor

* For the longer term (2020 and beyond), the French GFR demonstration reactor ALLEGRO should also be considered.

4. The Japanese HTTR constitutes a unique resource in that it is the only experimental high-temperature GCR available for a test program in the OECD countries. It is a graphite-moderated, helium cooled reactor that can reach temperature as high as 1 600°C in some transient conditions. The experiments planned by JAEA to study effects of RCCS performance reduction are highly relevant for HTR safety assessments. The HTTR is also suitable for neutronics, fission product release and graphite dust issues related to prismatic fuel arrangements. Actions should be taken to develop an international programme focused on the HTTR capabilities and on the safety issues identified in the present Task.
5. The Czech loop HTHL offers the opportunity to host separate effect tests carried out both out of pile and in-pile, hence offering the flexibility to address studies in which the combined effect of high-temperature gas environment and radiation are of relevance, such as for instance on fission product transport or high-temperature materials.
6. The HTTR and the HTHL plans are suitable for near term initiatives, i.e. for proposals that could result in defining an experimental programme in a 1-2 year time frame. Following current practice of CSNI projects, this action depends on the initiative of the host country and facility, as well as on co-operative support from other member countries. The NEA support to set up such programmes will be required.
7. Relevant CSNI Working Groups should be encouraged to share modelling information and discuss modelling activities relevant for GCR safety, in order to help focus the potential test programmes and/or enhance the data utilisation for model developments.
8. An activity in the field of thermal fluids and fission product behaviour in a GCR environment should be considered in the Working Group on Analyses and Management of Accidents (WGAMA), which has the advanced reactor item on its agenda. This activity may consist of a state-of-the-art assessment or of an international standard problem regarding GCR safety issues. This activity could help define medium term initiatives (3-5 years) for an analytical or experimental international programme in specific areas of interest.
9. The Working Group on Fuel Safety (WGFS) is currently considering a Workshop on the safety aspects of advanced fuel designs to be held in 2010. It is recommended that the Group proceeds with the organisation of the Workshop, including a session dedicated to GCR fuel safety needs and a discussion on further medium term WGFS initiatives in the GCR fuel safety area.

10. The Working Group on Integrity of Component and Structures (IAGE) should define plans for an activity in the area of GCR materials, aiming to assess the state of knowledge and define the data needs for safety assessments of high-temperature materials, graphite and ceramics, as well as options for obtaining such data through CSNI-driven international undertakings.
11. The French Commissariat à l'énergie atomique (CEA) is encouraged to keep the CSNI and relevant CSNI Working Groups abreast of the GFR design developments and the analytical and experimental advances to support such development, including proposals for specific experimental programmes where appropriate.
12. In particular, the CEA should provide updates related to their long term plans for the GFR demonstration reactor (ALLEGRO), which in the long term (approximately 10 years) could constitute a focus for joint international efforts.
13. The CSNI is to keep an adequate level of exchange with CNRA regarding needs and initiatives in the GCR safety area.

REFERENCES

- [1] Nuclear Energy Agency (NEA 2008), *The Role of Research in a Regulatory Context (RRRC-2), Workshop Proceedings, December 2007, Paris, France*, NEA/CSNI/R(2008)3, OECD, Paris.
- [2] NEA (2008), Summary Record of the 42nd meeting of the Committee on the Safety of the Nuclear Installations (CSNI), December 2007, NEA/SEN/SIN(2008)1.
- [3] NEA (2007), *Nuclear Safety Research in OECD Countries: Support Facilities for Existing and Advancer Reactor (SFEAR)*, NEA/CSNI/R(2007)6, OECD, Paris.
- [4] NEA (2008), *CSNI Collective Statement on Support Facilities for Existing and Advanced Reactors*, NEA/CSNI/R(2008)5, OECD, Paris.
- [5] Next Generation Nuclear Plant Phenomena Identification and Ranking Tables (PIRTs) (NUREG/CR-6944).
- [6] CSNI Operating Plan (2006-2009), NEA/CSNI/R(2007)7.
- [7] P. Anzieu *et al.*, Communication to TAREF regarding GFR main features (February 2009).
- [8] P. Richard *et al.*, "Status of the pre-design studies of the GFR core", PHYSOR 2008 Proceedings, Switzerland).
- [9] J.C. Lefevre *et al.*, European Fast Reactor design, Nuclear Engineering and Design, Vol 162, N°2, April 1996).
- [10] TRISO-Coated Particle Fuel Phenomenon Identification and Ranking Tables (PIRTs) for Fission Product Transport Due to Manufacturing, Operations, and Accidents (NUREG/CR-6844).
- [11] Natesan, K., Purohit, A., and Tam, S. W., 2003, "Materials Behaviour in HTGR Environments," NUREG/CR-6824 (ANL-02/37), Argonne National Laboratory, IL.
- [12] K. Natesan, K., A. Moisseytsev, S. Majumdar, and P. S. Shankar, 2006, Preliminary Issues Associated with the Next Generation Nuclear Plant Intermediate Heat Exchanger Design, ANL/EXT-06-46, Argonne National Laboratory, IL.

Appendix 1

DESCRIPTION OF EXPERIMENTAL FACILITIES FOR GCR SAFETY STUDIES

Facilities at Nuclear Research Institute Řež plc (NRI), Czech Republic

High-temperature Helium Loop (HTHL)

The HTHL is intended for the corrosion and irradiation tests of reactor component materials (reactor graphite and reactor pressure vessel internals) in helium atmosphere at high-temperatures and pressures.

The HTHL consists of a pressurised circuit with forced helium circulation in irradiation channel, which will be located in a core of the LVR-15 research reactor. Helium heating-up occurs by combination of heat exchanger, heater and radiation heating in the channel itself. The loop may operate at helium pressure up to 7 MPa and temperature up to 900°C (only in test section for specimens). The space for specimens is about $\phi 30 \times 500$ mm. The maximum flow rate of helium is 10 m³/h. The channel is connected to the filtration circuit. The purification rate is 5-10% of the main flow. The quality of helium can be controlled, thus making it possible to study corrosion with various helium impurities. Dosing, helium gas purification and impurities control and analytical methods for their evaluation may be performed as well. The HTHL is capable of both in-pile and out-of-pile tests. For the in-pile tests the whole loop will be moved from the experimental hall, where it is located now, to the LVR-15 research reactor building. They are both located in the Nuclear Research Institute Řež plc in the Czech Republic. The LVR-15 reactor has a nominal power of 10 MW and is well suited for irradiation with thermal flux up to 1.5×10^{14} n/cm².s and fast flux up to 2.5×10^{14} n/cm².s. In-pile testing can start in 2011.

The design of high-temperature helium loop with helium purification and dosing system

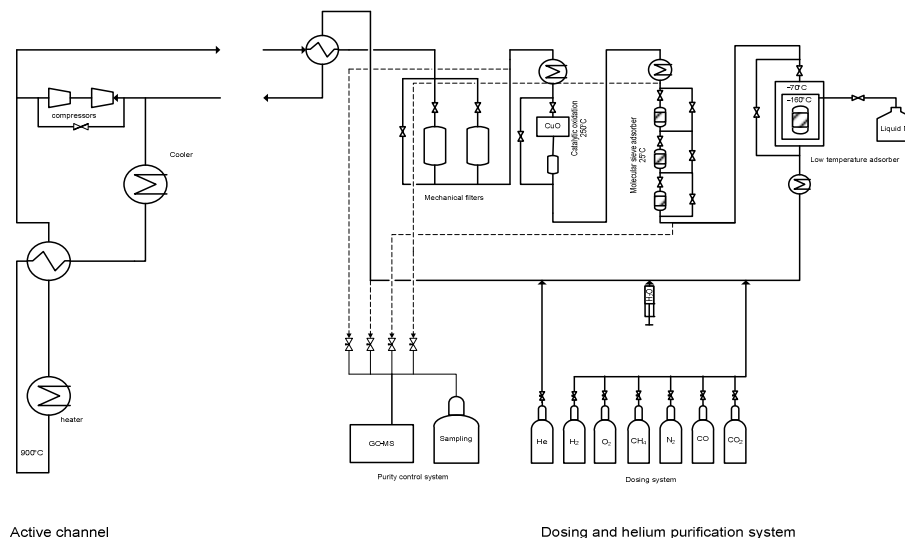

One of the purposes of HTHL is exposition of specimens of structural materials – metallic alloys, graphite, composites, etc. – in simulated VHTR conditions. Especially, graphite oxidation tests under irradiation could be performed in HTHL. Further, the HTHL can be used for helium purification system testing and optimisation. The construction of helium purification system enables testing of different types of adsorbents and other devices for impurities removal from helium and adjustment of physical parameters of the system is also available. Moreover HTHL enables the monitor the helium-chemistry e.g. for water or air-ingress simulation in presence of graphite. A number of complementary devices such as furnaces and equipments for mechanical and chemical testing are available at NRI.

Facilities at the Commissariat à l'énergie atomique (CEA), France (Mainly GFR-related)

SALSA

SALSA is a loop made to perform experimentations in support to CATHARE code validation, which is foreseen to be used for the reactor safety evaluation.

SALSA is an air loop with low technological constrains : low pressure (<1 MPa) and low temperature (<200°C). SALSA represents a reduce scale (1/3) of ALLEGRO which is the GFR demonstrator, and was designed with a correct global thermo-hydraulic similitude than ALLEGRO (exact similitude on Reynolds and Richardson number).

It is constituted by a primary loop and 3 decay heat removal (DHR) loops which can run in natural convection or forced convection states.

The heater vessel, simulating the core with a power of 180 KW, reproduces the lower plenum, and the upper plenum with the inlet/outlet of the DHR loops. The main air flow rate is 1,5 kg/s at a mean pressure of 1 MPa.

The height of the loop is 7 m and the base area is $7 \times 10 \text{ m}^2$.

ESTHAIR

ESTHAIR is a test section used to perform in air at low pressure and low temperature, hydraulic studies on a representative fuel core mocks up in order to determine heat exchange and friction correlations and also the velocity and pressure maps at the inlet and the outlet of the mocks up.

Up to now two type of core geometry were tested, corresponding to the two foreseen GFR core concepts:

- pin-type core;
- plate-type core.

HECO

HECO is an Helium loop which allows to test and qualify at scale 1 the DHR Circulator in representative ALLEGRO conditions in helium, in case of forced convection DHR strategy, during LOCA conditions. It allows also giving codes input data, in terms of performance maps, inertia, command laws.

The main specifications of this loop are:

- the mass flow rate of 1.5 kg/s;
- pressure scale between 0.2 and 7 MPa;
- inlet temperature of 260°C;
- compression rate of 1.05 (pressure drop of 0.01 MPa for 0.2 MPa).

The main size of the loop is a diameter of about 600 mm, a length of 8 m, and the architecture is based on the DHR loop with coaxial pipes. This device will be available at the beginning of 2011.

HETHIMO

HETHIMO is a device used to qualify thermal shieldings for pipes or cross duct. The experimental conditions are helium at a pressure up to 10 MPa and a temperature up to 1 000°C.

It looks like a pipe, with an internal diameter of 400 mm, and the thermal shield thickness is 100 mm. The height of the device is about 3 m. He flows by natural convection by means of a chimney in the central part of the device, and with a heater made with graphite resistors of 30 kW located at the lower part of the chimney. This He circulation allows to have temperature uniformity on all the inlet surface of the thermal shielding mock up, and so to determine a realistic thermal conductance of the mock up.

Accidental depressurisation simulations can also be made (up to 2 MPa/s) in order to validate the thermal shielding resistance for such constraints. This device is available, and was used to qualify two concepts of thermal shielding.

HELAN

HELAN will be used for the core barrel thermal shielding experimental qualification. The experimental conditions are helium at atmospheric pressure and at a temperature up to 1 250°C (simulating accidental transient conditions). The thermal shielding mock up looks like a flat panel composed with composite thermal insulation structure. The typical panel size is about 1x1x0.2 m³.

The HELAN device allows to test one panel mock up with a part of its neighbours, in order to see the interface behaviour. On the two flat sides of the mock up are located respectively cold source and hot source in order to simulate representative conditions. On the lateral parts of the mock up are disposed heat guards to avoid parasite heat flux.

The thermal shield mock up will be tested in stationary conditions up to 850°C, in order to study the behaviour of the mock up and also to determine its thermal conductivity. Simulated accidental transients up to 1 250°C can be realised. The bench will be free in rotation on 1 axis in order to study the influence of its orientation vs. gravity.

HEDYT

HEDYT is a dynamic Helium loop, and its main performances in the hot test section are:

- temperature of 850°C;
- pressure up to 10 MPa;
- the flow rate of 50 g/s.

The main components of the HEDYT loop are :

- The blower with a maximum He flow rate of 200 g/s. The inlet He temperature is limited at 50°C.
- Due to inlet temperature of the blower, in order to optimise the thermal power balance of the loop, an economiser of 100 kW is used.
- On the cold part of the loop with the blower, there are the cold cooler to assure cold He at the blower inlet, and a filter to protect the blower against particles in suspension with He.
- On the hot part, are located the high-temperature heater, the test section. Then the high-temperature cooler cool the He below the creep design temperature of structure. All the hot part, between heater and the cooler inlet, has a specific design with internal thermal shielding and a structure water cooler system for safety constrains.

This dynamic helium loop will be available with these conditions during 2009.

HETIQ

HETIQ is a device used to qualify high-temperature static seals, in relevant GFR condition (in helium up to 10 MPa and 1 000°C). This static He bench is currently available and is based on the same principal than HETHIMO. It has a cylindrical shape and He flows by natural convection by means of a chimney in the central part of the device, and with a heater made with graphite resistors of 30 kW located at the lower part of the chimney. Taking into account the high pressure and temperature working conditions, the structure of the bench is protected by an internal thermal shielding. The He circulation allows to have higher temperature at the chimney top where is located the seal test section. All bolts used for the compression of the seal are equipped with sensor loads in order to record during the test the evolution of the seal load. The leak is also measured by mean of He spectrometer. Temperature sensors allow the monitoring of the he heater power to have the good thermal load on the seal.

DEDIFAR

The aim of the DEDIFAR experiments is to give data in order to validate aerodynamic models of the value of the gas flow through an opened crack of a given geometry through a pressurised vessel. These models will be used in the FAR (in English: LBB, i.e. Leak Before Break) demonstrations for gas cooled reactors. The phenomena which must be taken into account are: singular and friction pressure losses, compressibility of the gas, flow choking, complex shapes. It is currently under operation.

The DEDIFAR 1 and 2 experiments used artificial cracks with a perfectly rectangular and constant cross section. DEDIFAR 1 addressed very narrow gaps openings (25 µm) with a flow at the beginning of the transition between laminar and molecular regimes. DEDIFAR 2 dealt with greater openings (0.2 mm).

The DEDIFAR 3 and 4 experiments also used artificial cracks with rectangular cross sections, but with a width (i.e. dimension perpendicular to the flow) depending on the abscissa along the flow, with the elliptic function predicted by fracture mechanics. The DEDIFAR 5 and 6 experiments which are presently in process use real cracks propagated by cyclic alternate bending. The propagation has been done at room temperature for the former, and it will be done at 450°C for the latter.

The results of more ore less sophisticated physicals models (0D, 1 D, 3 D CFD) are compared with the flow measured for a given pressure inside the pressure vessel.

HELITE

The objective of the HELITE facility is to have an experimental loop allowing performing technology tests or components qualifications in representative reactor scale, in support to GFRs and their demonstrator ALLEGRO. The present step of the HELITE design definition takes into account for its sizing the qualification of two critical components:

- Thermal shielding which imposes the helium flow rate.
- The IHX which imposes the temperature level and the temperature gradient.

Others qualifications are planned on this loop, but they are not critical from a loop sizing point of view.

HELITE consists of two main loops:

- An Helium loop which represents the primary loop of the reactor.
- A (He-N₂) loop which represents the secondary loop of the reactor and is necessary to test an IHX mock up. The present choice of the gas mixture is not definitive considering the nitriding risk at this temperature level.

The two loops are designed in the same way than the HEDYT loop, with:

- A blower with a limited inlet He temperature at 50°C.
- Due to the inlet temperature of the blower, in order to optimise the thermal power balance of each loop, economizers are used.
- On the loops cold leg, before the blowers, the cold coolers insure cold He at the blowers inlet, and filters protect the blowers against particles in suspension in gas.
- On the Helium loop hot leg, are located the high-temperature heater and the test section. Then the high-temperature cooler cools the He below the creep design temperature of the structure. All the hot part, between heater and the cooler inlet, has a specific design with internal thermal shielding and a structure water cooler system for safety constraints. For IHX qualification program, the high-temperature cooler is replaced by the IHX mock up to be tested.
- On the (He-N₂) loop hot part, used for IHX qualification, coolers are located before and after the IHX mock up in order to adjust both the inlet temperature of the mock up and the inlet temperature of the economiser.

The main characteristics of the He HELITE loop are:

- Temperature of 850°C, (with an optional super heated stage up to 1 000°C).
- Pressure up to 10 MPa.
- He flow rate of 400 g/s.

The main characteristics of the (He-N₂) HELITE loop are:

- Temperature of 800°C, (950°C with the optional super heated stage).
- Pressure up to 5 MPa.
- Gas flow rate of 1100 g/s.

HELITE is foreseen to be built after 2012. Detailed design is available.

TAMARIS

CEA has a platform for seismic testing called TAMARIS and enable to validate the GFR designs. The TAMARIS infrastructure and its main shaking table AZALEE belong to the Seismic Laboratory which has 40 years experience in experimental and analytical earthquake engineering.

The testing facility, TAMARIS, is part of the Seismic Laboratory and has a staff of about 20 researchers and technicians. Its objectives are model development and validation, calculation methods development and qualification, codification, seismic qualification of components and assessment and retrofit of existing facilities. TAMARIS infrastructure, which was opened in 1988, is characterized by:

- The capacity of AZALEE shaking table with 100 tons capacity (allowable model mass) is the largest shaking table in Europe. At this day, tests with masses up to 92 tons have been successfully performed. This 6 m×6 m and 6 degrees of freedom shaking table allows testing of specimens under independent excitations of any kind: (sinusoidal, random, shock and time history with 0-100 Hz frequency ranges). Maximum accelerations of 1 g in the horizontal and 2 g in the vertical directions can be applied to specimens approaching the maximum payload of the table.
- Three other smaller shaking tables with similar maximum acceleration, velocity and displacement but reduced capacities in term of mass and degrees of freedom are used for qualification and research experimental programs
- A high quality control and acquisition system allows recording and processing of 256 channels and is linked with a scientific computing and processing system used for the definition and the accomplishment of tests and subsequent interpretation. In recent years, the infrastructure equipment has been permanently upgraded (a new digital controller is being installed for AZALEE during 2008).

The Laboratory is part of a service with about 100 engineers, scientists and technicians involved in different fields of mechanical engineering (static, dynamic, vibrations, fluid-structure interaction, fracture mechanics, material engineering, computer science, code development, etc.).

A generic finite element computer code CAST3M is designed, developed and used in support of the Research and Development activities, especially for preparation and interpretation of the experimental campaigns. This homemade FEM programme is largely used and developed in Universities and R&D centres in France and Europe (JRC Ispra, Univ. Porto). Important developments and applications concern nuclear equipments with fluid structure interaction, contact and material nonlinearities. This software also represents an opportunity for paving the way towards hybrid testing whose importance is increasing in experimental earthquake engineering.

TAMARIS is presently available.

PLINIUS (www.plinius.eu)

The CEA PLINIUS platform is used for testing and simulating severe accidents. It can be adapted to GFR scenarios including ceramic materials. The PLINIUS platform is operational and consists of:

- VULCANO: VULCANO is a 50-100 kg corium melting facility. It is possible to melt oxides and metals (in depleted uranium) and to mix them for a VULCANO experiment.

- COLIMA: COLIMA is a small scale (few kg) facility with induction heating (up to 170 kW) and a thermostatic 1.5 m³ enclosure in which it is possible to monitor the gas atmosphere. COLIMA has been up to now used to study aerosols, material interactions, physical properties.
- KROTOS: KROTOS is a Corium-Water Interaction facility in which up to 5 kg corium is molten and dropped into water. Energetic steam explosions can be triggered and studied.
- VITI: VITI is PLINIUS smallest scale (~ 10-100 g) facility. VITI is suitable to small scale interaction experiments and to study of thermophysical and thermochemical properties. A levitating droplet device has been developed to measure corium viscosity and surface tension. Crucible tests have also been performed in VITI. It will soon be used to test the interaction of potential core-catcher sacrificial materials with UO₂-Fe. Uranium Carbide can be envisaged as a future material to test.

MERARG

MERARG 2 is an oven heated by induced current, located in a hot cell and which is coupled to an on line measurement system of gas released from a fuel sample.

This oven has been used up to now to understand the fission gas release from various fuels (high burn-up UO₂, MOX, MOX with advanced microstructure, MOX irradiated in a BWR, nitride fuel, fuel for nuclear propulsion). This oven can accommodate very different surrounding conditions: Helium, argon or air atmosphere and temperatures ranging from 350°C to 2 800°C using irradiated fuel samples. It has been recently upgraded to enlarged capabilities: a new optical pyrometer, a gamma scanning to measure on line the release of non gaseous fission products from the fuel, and a chromatograph dedicated to non active gas release. This facility is under operation.

ENIGMA

ENIGMA is a program on prototypic GFR materials in the zero power reactor MASURCA.

The critical facility MASURCA, of a very low power (5 kW), is dedicated to the neutronic studies of Fast Reactors lattices. The adaptability of the MASURCA core allows the validation of innovative core designs. Since its start-up, the MASURCA facility has provided an important contribution to the development of the core calculation schemes used for the design of Fast Power Reactor. This reactor is also a remarkable tool for the validation of experimental techniques: lot of determination used for SUPERPHENIX were tested during the RACINE (1978-1984) and BALZAC programmes. Most of these experimental programmes are realised within an international cooperation involving mainly nation of the European Community, but also Russia, USA and Japan in the framework of international benchmarks.

The reactor

The different materials of the core are contained in a parallelepiped or cylinder form with a square or circular basis of half an inch for the side or diameter and 4 or 8 inches for the height. Such sizes are compatible with most of the dimensions of similar facilities around the world. The plutonium, in the form of mixed oxide, is clad with stainless steel, such as the sodium. The enriched and depleted uranium is contained in rodlets clad with a superficial protection of nickel. These rodlets are put into wrapper tubes having a square section (4*4 inches) and about 3 meters in height. These tubes are hanged vertically from a horizontal plate supported by a structure in concrete. The core volume itself can reach 6 000 litres. The reactivity control is assessed by absorber rods in

varying number depending of core type and size. The rods are composed of fuel material in their lower part and absorber material in their upper part, so that the homogeneity of the core is kept when the rods are withdrawn. The core cooling is provided by air. The core is surrounded by biological shielding in heavy concrete allowing operation up to a flux level of $10^9 \text{n}/(\text{cm}^2 \cdot \text{sec})$.

The measurements

The MASURCA facility allows an easy access to measurements:

- Activation foils can be put everywhere in the subassembly.
- Special channels can be opened throughout the core to introduce different measurement devices (fission chambers, activation foils):
 - two horizontal channels at 90° around the core midplane;
 - axial channels can be put into any subassembly.
- Several counters are distributed inside the core to monitor the flux and produce the elements for a static (source multiplication) or dynamic (inverse kinetics) analysis of reactivity variations.

MASURCA is presently under refurbishment and will resume operation in 2011.

ALLEGRO

ALLEGRO is an experimental prototype of GFR, studied in a European framework. With a thermal power around 80 MWth, it will not produce any electricity. Helium, a transparent and neutral gas, is used as a pressurised primary coolant. It incorporates, at a reduced scale, all the architecture and the main materials and components foreseen for the GFR, except the power conversion system. Its safety principles are those proposed for the GFRs: core cooling through a gas circulation in all situations, ensuring a minimal pressure level in case of a leak thanks to a specific gas-tight envelope surrounding the primary system. It will also contribute to developing and qualifying innovative refractory fuel elements that can withstand high-temperature levels.

A 10 MWth derivation from the main heat exchanger/cooling system could be developed to connect an experiment using high-temperature heat coming out from the core, to simulate a process at a significant scaling. The table below gives an overview of the main core performance and the experimental capability.

Core	Management	Fast neutron Φ	Dose	In core volume
25-30% Pu	F1 – 660 EFPD	$8.4 \cdot 10^{14} \text{ n}/\text{cm}^2 \cdot \text{s}$	15	6×5 litres
75 MW	or F5 – 2000 EFPD	($E > 0.1 \text{ MeV}$)	dpa/year	

In a logic where this reactor will be built before a GFR refractory fuel element is completely validated, such a validation being precisely one of the objectives assigned to the reactor, ALLEGRO will start-up with a core based on an improved technology: a pin type fuel with a metallic clad. Such a core will be designed to include later on several sub-assemblies of innovative technology (carbide fuel with ceramic clad) and to be finally completely set up with this type of fuel. This progressive approach shall allow qualifying new technologies under representative conditions.

ALLEGRO is designed for a core power density of $100 \text{ MW}/\text{m}^3$. The first cores consist of UPuO_2 pins with 25% Pu, clad with optimised 316-Ti stainless steel. Fuel pins are the same as the one in the driver core of the PHENIX reactor. The fertile axial blanket has only been suppressed, which

allows taking benefit from all the knowledge acquired for many decades on this type of fuel. Six locations can hold an experimental ceramic fuel sub-assembly.

When the ceramic fuel will be qualified, after some 2 000 EFPD to reach a maximum fuel burn-up of 8 at%, the substitution of the MOX core by a ceramic core will permit to raise the operating temperature at the outlet of the core. Performance of the ceramic cores are estimated to be well representative of a GFR core as it is foreseen today in terms of temperatures, damages to structures, and fuel burn-up.

ALLEGRO is under pre-conceptual design studies and is scheduled to start-up in 2020.

Facilities in Germany, various institutions

L-STAR – Forschungszentrum Karlsruhe (FZK)

The L-STAR (**L**uft, **S**Tab, **A**bstandshalter, **R**auhigkeiten) project is focussed on heat transfer and pressure drop issues of the gas cooled systems for transmutation. The available database shows a variation of app. 50% for smooth surfaces and is not sufficient to assess CFD tools. To enhance heat transfer various surface textures will be investigated. L-STAR includes two facilities, a small loop (S-Loop) with on compressor and the L-STAR loop with a 3 stage compressor station. The working fluid is air, nitrogen, and later CO₂.

Both loops are instrumented by invasive and non-invasive measurements to address mass flow rate, temperatures, pressure, and local fluid velocity. A sophisticated LDA profile sensor is under development in cooperation with University of Dresden (TUD) which will allow to measure local velocity and turbulence profiles required for CFD qualification.

The S-Loop has reached mass flow rates up to 0.1 kg/s and Re ~50 000 at room temperature. In L-STAR the maximum temperature of the central heater rod is planned to be 700°C at a pressure of 0.4 MPa with a mass flow rate of app. 0.3 kg/s. An innovative particle extraction system is under test in S-Loop.

ITHEX – Forschungszentrum Karlsruhe (FZK)

The ITHEX facility features is a closed gas loop instrumented for mass flow rate, pressure and temperature measurements, as well as high resolution optical flow measurement techniques such as Laser-Doppler Anemometry (LDA), Particle Image Velocimetry (PIV), and Laser Induced Fluorescence (LIF), completed by Constant Temperature Anemometry (CTA).

The gas loop can be evacuated, and operated with various gases, such as Nitrogen, Helium, Argon or ambient air. To circulate the gas, four speed controlled side-channel compressors are used in series with intercooling. The mass flow rate is measured by a Coriolis massflow sensor, which is independent of the gas composition. Typical operating conditions are 0.1-0.4 MPa at the testsection inlet, up to 200°C at the testsection outlet, and pressure differences of up to 0.12 MPa over the testsection. The massflow rate for a typical testsection with a cross-section 1 mm x 45 mm and a length app. 100 mm, can reach up to 16 g/s with Nitrogen at 0.3 MPa. The facility provides a heating power up to 15 kW.

Previous and ongoing measurement campaigns are focused on heat transfer and turbulent flow studies in mini-channel to deliver a database for CFD code qualification.. Mini-channels with flat and annular cross-sections with a gap width of 0.6-1.0 mm were investigated, yielding results for local heat

transfer, friction coefficients and velocity profiles. The studies will also include heat transfer enhancement techniques.

HEBLO – Forschungszentrum Karlsruhe (FZK)

The HEBLO (**HE**lium **BL**anket Test**LO**op) facility was erected to investigate components for FUSION reactors. The original focus was to investigate the dynamic behaviour of the TBM (Test Blanket Modul) under accidental conditions and to qualify systems codes used to simulate the dynamics of the TBM cooling system. The facility consists of a main loop and a test loop connected by an intermediate heat exchanger (IHX) forming an “8”-shape.

The main loop contains: the blower with a gas bearing, the He-cooler, connections to different test sections for isothermal tests at room temperature, control devices such as bypass and valves to control the net He-mass flow rate, He-injection, and the He purification system.

The test loop includes: connections to the test section, He-heaters, bypass lines and valves to control mass flow rate through test section, heat buffer with high heat capacity to flat temperature gradients. Various test sections have been developed to test heat transfer for Blanket and Divertor modules.

Parameter	Main loop	Test loop
System pressure:	8.0 MPa	8.0 MPa
Max. He temperature:	120°C	450°C (500°C)
Max. mass flow rate of the blower at 50°C:	100 m ³ /h or 330 g/s	120 g/s
Max. heating power app.		150 kW
Max pressure difference of the blower:	0.15 MPa	
Heat exchanger capacity	115 kW	
with He-temperature at blower inlet / exit:	120°C/50°C	
and water temperature inlet/exit	35°C/40°C	

HELOKA – Forschungszentrum Karlsruhe (FZK)

The helium loop Karlsruhe (HELOKA) is a new test facility under construction at the Forschungszentrum Karlsruhe (FZK) (FZK) for the testing of various components for nuclear fusion such as the Helium-cooled pebble bed blanket (HCPB) and helium-cooled-divertor for the DEMO power reactor.

This loop is a closed loop operated with pressurised Helium (10 MPa) at high-temperature (300-500°C). HELOKA has an “8”-shape, with a gas-gas heat exchanger (economiser) transferring heat from the hot leg into the cold leg. With this kind of configuration a low temperature circulator can be used without wasting energy. Thus, a part of the heat introduced into the system is recuperated reducing the heating power requirements. A circulator provides a constant He mass flow rate in the circuit up to 1.4 kg/s. A by-pass system in parallel to the test section allows adjusting the required He flow in the test section according to the defined test. The loop also includes a He supply and pressure control system.

The present design allows also the extension of the loop with an additional branch where very high-temperature (up to 900°C) tests are foreseen.

The loop is currently prepared for the assembly with commissioning in October 2009. In the first half of 2010 it is foreseen to optimise the control of the loop and prepare the loop section that hosts the test module for the future experiments that should start in the second half of 2010.

A2 – Forschungszentrum Karlsruhe (FZK)

The A2, the former FAUNA (ForschungsAnlage zu UNersuchung von Aerosolen) facility, is a huge cylindrical pressure vessel of 220 m³ volume with a design pressure of 1.0 MPa and average design temperature of 150°C. It was first used to investigate sodium fires due to sodium sprays and aerosol behaviour.

Later the facility housed experiments on severe accident phenomena in light water reactors, concerning in-vessel fuel coolant interactions without (PREMIX) and with steam explosions (ECO). Presently the facility is being prepared to perform dust/hydrogen distribution and combustion experiments for fusion safety research (ITER). Other future activities will investigate direct containment heating processes for PWR safety and dynamic high-temperature gas discharge phenomena for gas-cooled reactors.

The facility has a volume of 220 m³, operating pressure of 1 MPa and temperature of 150°C. It is presently in the pre-operative state, pressure vessel licensing has been upgraded and the instrumentation and control system are being refurbished.

NACOK – Forschungszentrum Jülich (FZJ)

The large-scale NACOK facility (natural flow inside the core with corrosion) at Jülich was designed in order to study the process and impact of accidental air ingress in the HTR helium loop and to validate respective numerical codes.

Basic data:	total height of facility:.....	10 m
	cross section main channel:.....	0.3×0.3 m ²
	max. pebble bed height:	6.4 m
	design temperature main channel:.....	1 200°C
	design pressure: atmospheric	
	heat output installed:	160 kW
	max. air flow rate:	17 g/s

NACOK can be used for studies on various phenomena related to gas-cooled reactors such as graphite oxidation, thermal hydraulics, heat transfer in pebble bed, etc.

GOLAB – Forschungszentrum Jülich (FZJ)

The GOLAB facility (Graphite Oxidisation Lab) was designed for small-scale studies on phenomena related to the oxidation behaviour of graphite and further innovative carbon based materials (CFC, SiC, Composites, doped materials) in standardised experiments.

REKO – Forschungszentrum Jülich (FZJ)

Several small-scale facilities in the Hydrogen Laboratory (REKO facilities) are available for studying phenomena related to the possible hydrogen release in gas-cooled reactors after water ingress. In a foreseen expansion of the laboratory experimental studies on airborne fission transport will be possible as well. Existing knowledge in the field of hydrogen safety are transferable to HTR applications as well.

GLoop – Forschungszentrum Dresden/Rossendorf (FZK)

GPLoop (gas-particle loop) is a small-scale experimental facility for the study of transport, (re)mobilisation and deposition of graphite (or other) gas-borne particles. The loop is about 1m×2m size with 100 mm diameter pipework and different test sections for the study of powder/particle behaviour at obstacles, bents and core elements (pebbles, block channels). The loop is operated with a variable He/N₂ mixture up to 2 MPa pressure, 20 m/s gas velocity and up to 1 kg solid fraction. Special instrumentation, such as high speed camera, PIV and radiotracer instrumentation allow measurement of gas and particle velocity as well as local deposition and mobilization rates with high spatial and temporal resolution. The facility is dedicated to experiments for CFD code development and validation for HTR safety issues (graphite grit transport, contamination and retention issues) Commissioning of the facility is planned beginning of 2010.

Contact:

Institut für Sicherheitsforschung
Herrn Dr. Ing. habil. Uwe Hampel
Tel.: +49-(0)351-260-3484
mailto: u.hampel@fzd.de

High-Power-Laser-Laboratory – Technische Universitaet Dresden (TUD)

The Laser-Laboratory is equipped with:

- A CO₂ laser with 10 600 nm wavelength with a beam power in continuous mode of 2 kW (cw).
- A diode laser with 808 and 940 nm wavelength, beam power in continuous mode of 3.1 kW (cw).
- A diode laser with 915-940-980-1030 nm wavelength, power in continuous mode 10 kW (cw).
- A pulsed excimer laser with pulse energy of 1 J.

All laser beams, excluded the excimer laser, can guide by high power laser scanners, so the energy distribution on the target surface can be controlled very flexible. A complete vacuum chamber system can be used for experiments with all laser systems. Additional to the laser equipment, infra-red thermo cameras are available to get information's about the temperature field on the surface of the radiated bodies. The equipment was completed by a laser spectroscopy based on a Neodymium-YAG-Laser. The laser laboratory will be used to join ceramic materials like SiC, Si₃N₄, Al₂O₃ etc. The joining process is generally realized in free atmosphere or, if necessary, in vacuum or protective gas atmosphere.

High-Temperature-Furnace – Technische Universitaet Dresden (TUD)

The furnace is a graphite tube type, electrically heated with a helium protective atmosphere in the main chamber. Reached maximum temperature is 1 600°C. The usable furnace room has a diameter of 150 mm and a height of 250 mm. Combined with a special internal tube, corrosion tests can be realized in it. The facility can be used to investigate the corrosion behaviour of graphite structure elements, coated particles, and graphite spheres (non-active materials only).

Contact:

Prof. Dr.-Ing. habil. Antonio Hurtado
Technische Universitaet Dresden
Institute of Power Engineering
Chair of Hydrogen- and Nuclear Energy
Tel.: +49-(0)351-463-34472
e-mail: Antonio.hurtado@tu-dresden.de

Dr.-Ing. habil. Wolfgang Lippmann
Technische Universitaet Dresden
Institute of Power Engineering
Chair of Hydrogen- and Nuclear Energy
Tel.: +49-(0)351-463-34793
e-mail: wolfgang.lippmann@tu-dresden.de

THAI Facility – Becker Technologies GmbH

The THAI facility is a unique technical scale experimental facility for research in the area of nuclear reactor containment safety. It enables to simulate various thermal-hydraulic scenarios ranging from turbulent free convection to stagnant stratified containment atmospheres. It consists of a 60 m³, multi-compartment test vessel with 9.2 m height and 3.2 m diameter. The cylindrical part of the vessel is equipped with three independent jackets over the height for controlled heating or cooling of the walls. The compartments can be arranged to model room chains and networks, plena, dead-end compartments and flow ducts. They are interconnected by vent ducts which can be opened, closed or reduced in size according to the requirements of the specific test runs. Helium and graphite dust can be prepared in an external tank and alternatively released at different locations within the multi-compartment vessel.

Measuring flanges on five levels at five circumferential positions allow the installation of in-situ optical and conventional instrumentation. Amongst others the instrumentation includes 2D/3D Particle Image Velocimetry, 2D/3D Laser-Doppler Anemometry for flow field and profile measurements, iodine-123 radio-tracer technique with in-situ gas scrubbers, mass spectrometry and heat conductivity sensors for gas concentration measurements. Furthermore impactors, photometers, automated filter stations, deposition coupons for aerosol monitoring and comprehensive thermal hydraulic instrumentation are available to monitor the phenomena in individual sub-compartments. In THAI experiments can be performed to investigate He/Air distributions during and after postulated transients, as well as the properties, transport and spacial distribution behaviour of graphite aerosol in single- and multi-compartment arrangements.

Contact: Gerhard Poss poss@becker-technologies.com Tel.: +49(0)6196 - 936 101

Facilities at ENEA, Italy

HE-FUS3 (European helium-cooled blanket test facility),

ENEA is operating the HE-FUS3 facility at own Brasimone Research centre, located 60 km from Bologna in the Apennines. That facility was built in the period 1994-96 in the frame of the European Test Blanket Development Programme for performing Non Nuclear Tests on module subassemblies of the helium-cooled solid breeder blanket (HCPB) developed for DEMO Reactor and to be tested in ITER Reactor. The facility will be upgraded to be used also for the development of another European blanket concept (helium-cooled lithium-lead – HCLL), modifying the performance of some components (compressor and economizer). It has also been used to test a plate-type heat exchanger developed for a VHTR in the frame of the European RAPHAEL Integrated Project.

The HEFUS3 facility has a closed eight-shaped loop arrangement divided in two zones at different temperatures. The hot zone consists of piping of 5-inch diameter to limit the helium velocity, three identical modules of electric heaters (it is possible to operate with 1, 2 or 3 modules; nominal power of each module: 70 KW), a Test Section provided of 7-pins bundle equipped with thermocouples (total power: about 350 KW), a hot mixer that makes uniform the temperatures of the main and bypass flow rates, a bypass line connecting the economiser-expansion tank line of the cold zone with the hot mixer and its control valve that allows to regulate the Test Section inlet temperature. The Test section outlet temperature has to be lower than 530°C. An economiser, placed at the crossover point of the hot and cold zones, allows the recovery of the helium enthalpy before the inlet to the compressor. The cold zone consists of a main loop of 4-inch diameter piping, a counter flow helium-air cooler for reducing the compressor inlet temperature (He and air flow rates: 3.5 and 6 kg/s, respectively; exchanged power: 280 kW), a prototypical compressor with the electric motor immersed in helium and the impeller shaft supported by helium flow injected at required pressure in the gaps between the shaft and

bearing without using any lubricant (maximum operating temperature: 100°C; max flow rate: 0.35 Kg/s, head: 0.5 MPa), an expansion tank located at compressor outlet to dump any pressure and flow fluctuations during the loop operation, a cold mixer for mixing the main and cold bypass flow rates, and a cold bypass line connecting the economizer-expansion tank line and the cold mixer.

The flow measurement is performed with two Vortex flow rates and the mass flow rate is derived measure obtained integrating the volumetric flow with measurements of temperature and pressure upstream of the flowmeter location. NiCr/NiAl thermocouples and thermo-resistances are used for temperature measurements: the former for temperature higher than 200°C. The thermocouples of the control chains are directly exposed to fluid to measure as fast as possible the real temperature. The pressure measurements are based on diaphragm cell transmitters. Control chains are foreseen for: 1) Test Section inlet and outlet helium temperatures; 2) outlet helium temperature of the last two electric heater modules; 3) compressor helium flow rate; and 4) air cooler outlet helium temperature.

A protection system for the facility emergency shutdown is based on the outlet helium temperatures of the controlled heaters modules and the air cooler. The facility is provided also of the following auxiliary systems: 1) filling and pressurization, 2) gas analysis; 3) purification, 4) helium discharge to environment; 5) vacuum preservation; and 6) system control. The loop is designed to operate at the following operative modes: 1) Long term isothermal cooling flow; 2) Slow thermal cycling flow; 3) Fast cold thermal shock flow; 4) LOCA/LOFA and power excursion simulation. The performances of two components (economizer and compressor) after the upgrading will be:

- a) Compressor (max head: 0.5 \Rightarrow 0.9 MPa; flow rate 0.35 \Rightarrow 1.4 kg/s)
- b) Economiser (thermal power: 564 KW \Rightarrow 1490 kW)
- c) Mockup thermal power (fusion R&D): 350 \Rightarrow 1000 kW

The facility has a maximum outlet temperature in the hot zone at 530 °C. It has availability limited to periods in which the facility is not used for fusion testing activities.

References: <http://web.brasimone.enea.it/> select “experimental activities” \Rightarrow Main Facilities \Rightarrow HEFUS3

Facilities at JAEA, Japan

HTTR (High-temperature gas-cooled reactor of Japan)

Outline of facility and testing: The high-temperature engineering test reactor (HTTR) of the Japan Atomic Energy Agency (JAEA) is a graphite-moderated and helium gas cooled reactor with an outlet coolant temperature of 950°C and a thermal output of 30MW. The HTTR uses pin-in-block type fuel assembly. The major objectives of the HTTR are to establish and upgrade the technological basis for advanced high-temperature gas-cooled reactors (HTGRs) and to conduct various irradiation tests for innovative high-temperature basic researches. Safety demonstration tests are conducted for the purpose of demonstrating inherent safety features of HTGRs as well as providing the core and plant transient data for validation of HTGR analysis codes for safety evaluation.

Status: The HTTR attained the first criticality on 10 November, 1998, and achieved the reactor outlet coolant temperature of 950°C on 19 April, 2004. Since 2002, safety demonstration tests simulating anticipated operational occurrences such as decrease of primary coolant flow-rate and reactivity insertion have been carried out. Licensing for accident simulation tests such as loss of forced cooling and all blackout was completed. Various tests utilising the HTTR have been performing.

Instrumentation: The reactor instrumentation measures the major parameters in the operation condition of the HTTR, such as the neutron flux, the position of control rods, the differential pressure in the core, the coolant temperature at the hot plenum and fission products from failed fuel. The

nuclear instrumentation system of the HTTR is composed of a wide range monitoring system (WRMS) and a power range monitoring system (PRMS). The WRMS and PRMS are used to measure the neutron flux from 10^{-8} to 30% and 0.1 to 120% of rated power, respectively. To measure the core outlet coolant temperature of the primary coolant, 28 N-type thermocouples (Nicrosil-Nisil) are installed in the hot plenum blocks below the reactor core. There are also many thermocouples on core internals and reactor pressure vessel. The plant parameters such as coolant temperature, pressure, flow-rate, radioactivity, etc. are measured during the reactor operation. There are about 4 000 sensors in the HTTR, and the signals from the sensors are centralized by the plant computer.

References: www.jaea.go.jp/04/nsed/naht/index.html, then select “ENGLISH”.

S. Shiozawa, *et.al.*, Overview of HTTR design features, Nucl. Eng. Des. 233(2004)11-21.

NSRR (Nuclear Safety Research Reactor)

Outline of facility and testing: (NSRR) of the Japan Atomic Energy Agency (JAEA) is a modified TRIGA ACPR (annular core pulse reactor) with a power pulse capability to simulate a power excursion anticipated in a reactivity-initiated accident (RIA). At the maximum reactivity insertion of \$4.67, the peak power reaches approximately 23 GW and the width of power pulse is about 4 milliseconds. Another feature of the NSRR is a large (220 mm in diameter) center cavity of reactor core which enables sample irradiation with high neutron flux and easy loading/unloading of a test sample contained in a test capsule. The NSRR was constructed in 1975 and has been used mainly for safety research of light water reactor (LWR) fuels, but other types of fuels were also tested, including research reactor fuels such as aluminum-based uranium silicide (U_3Si_2) fuel, uranium/zirconium alloy (U-Zr) fuel, and high-temperature gas-cooled reactor (HTGR) fuel. The variety of test fuels and test conditions can be extended by developing a new test capsule. For example, the recently developed high-temperature capsule enabled a test at up to 280°C with high burnup fuels.

Status: RIA-simulating tests with fresh fuel rods started in 1975. After facility modification, tests with high burnup fuel rods started in 1989. Since 2002, an extensive test program, Advanced Light water reactor fuels Performance and Safety research program (ALPS), has been undertaken with a financial support by the Nuclear and Industrial Safety Agency of the Ministry of Economy, Trade and Industry (NISA/METI) of Japan. High burnup UO_2 and MOX fuel rods irradiated in European nuclear power stations were transported to JAEA and have been tested at the NSRR. In another test program from 2006 to 2008 supported by the Ministry of Education, Culture, Sports, Science and Technology (MEXT) of Japan, pulse-irradiation tests of fresh HTGR fuels were performed. Only one test with irradiated HTGR fuel was performed in 1994. Since then, the NSRR is ready for the next test, but irradiated HTGR fuels are unavailable in Japan as of April, 2009.

Instrumentation: Transient measurements are performed in the pulse-irradiation test at the NSRR. The measurement items with the reactor are the NSRR power and the time-integrated NSRR power. The typical measurement items with the test fuel/capsule are cladding surface temperature with direct-welded thermocouples, coolant temperature with sheathed thermocouples, rod internal pressure with pressure sensors build in the rod end plug, capsule pressure with pressure sensors located in coolant and in cover gas, cladding and fuel elongation with LVDT extensometers, water column velocity with a float-type velocimeter, and so on. The measurement availability can be extended by sensor development. All signals from sensors are digitized at high sampling rates up to 1 MS/s. As for the HTGR fuels, a failure fraction of TRISO fuel particles in terms of temperature, failure mode, behaviour of fission gas can be investigated through post-pulse fuel examinations.

References:

Saito, S., *et al.*, “Measurement and evaluation on pulsing characteristics and experimental capability of NSRR,” *J. Nucl. Sci. Technol.* **14**[3], pp.226-238 (1977).

Sasajima, H., *et al.*, “Behaviour of irradiated PWR fuel under simulated RIA conditions – results of the NSRR tests GK-1 and GK-2”, JAERI-Research 2004-022 (2004).

Umeda, M., *et al.*, “Behaviour of HTGR Particle Fuel under Reactivity Initiated Accident Condition”, Transactions of the ANS and Embedded Topical Meetings Isotopes for Medicine and Industry and Nuclear Fuels and Structural Materials for the Next Generation Nuclear Reactors, Anaheim, USA, June 8-12, 2008, p. 987 (2008).

Facilities at the Paul Scherrer Institute (PSI) in Switzerland²

The SWISS-GAF Facility

PSI has recently initiated an activity in a facility denominated SWISS-GAF aimed to elaborate the feasibility of establishing a project to study mainly the “graphite dust issue” under operational and accidental conditions in interest to HTR designs. The anticipated project will study several issues starting with the dust generation and transport in HTR primary coolant loop including the core and in the compartments of the confinement/containment. The air ingress and its distribution in the coolant loop is the other thermal-hydraulic issue to be tackled. The importance of the graphite dust is different for two different core configurations, i.e., the pebble bed and prismatic cores. However, operational conditions, e.g., level of impurities, may provoke different conditions for enhanced dust generation, but at different rate depending on the HTR design, which otherwise may not be feasible. As in the light water reactors, aerosols will be the main carrier for the transport of the active fission products also in the HTR concepts. The released activity (Ag, Cs, I, Sr, etc) will be plated-out on such dust particles, therefore, characterization of dust generation under all planned operational and anticipated accidental conditions is of safety relevance, together with its plate-out/transport behaviour in the primary coolant piping including the core and also in the confinement/containment. The project will not involve active fission products and their release from the core.

The project under planning will offer the opportunity to experimentally study many important issues at integral level as well as at separate effect level, and will produce high quality data needed for many different applications ranging from safety evaluation to CFD model development and verification.

The planned project will be active in the areas as described in the following tables of the present report:

- a) Table A-3
- b) Table A-6
- c) Table A-8
- d) Table B-2
- e) Table B-4
- f) Table B-5

2. This note on the SWISS GAF Facility is an addition to what was requested after the report was completed.

Facilities in the United States, various institutions

Idaho National Laboratory (INL)

- Thermal Fluids – INL has the following facilities for gas reactor core cooling studies: (a) air ingress experiments, (b) lower-plenum-to-upper-plenum density-gradient driven flow facility, (c) turbulent mixing in lower core region and lower plenum at operational conditions, (d) bench-top experiments, and (e) integral facility, and the Matched-Index-of-Refractive (MIR) facility.
- Fuel – INL’s Hot Fuel Examination Facility (HFEF) contains large alpha-gamma hot cells for performing state-of-the-art post-irradiation examination (PIE) activities on irradiated fuel and assemblies. The INL Analytical Laboratory contains various analytical chemistry capabilities to support irradiated fuel characterisation and examinations (e.g., fuel dissolution and experimental burnup determinations, radiochemical analysis methods of fission product condensation plates from the furnace high-temperature fuel accident tests). The Electron Microscopy Laboratory (ELM) contains equipment for sample preparation and microanalysis on low-dose fuel samples (e.g., scanning electron microscopy (SEM), elemental analysis, and metallography). The ELM will have a shielded electron microprobe, which will allow high resolution elemental microanalysis on irradiated fuel samples.

INL is developing a facility to investigate the release of fission products from fuel at high-temperatures in a helium environment. The furnace has a maximum temperature of 2 000°C and can accommodate fuel samples up to 6 cm in diameter. The furnace system possesses a water cooled cold finger that is inerted near the top of the hot zone during operation. Metal plates attached to the end of the cold finger act as fission product (e.g., ^{110m}Ag , ^{137}Cs , ^{90}Sr , ^{154}Eu) condensation surfaces, and can be exchanged multiple times during a fuel annealing test. Analysis of the radionuclides on the plates gives the inventory released from the fuel during each time interval, allowing the time-dependent release of condensable fission products to be determined. The system also continually measures the release of noble fission gases from the fuel (e.g. ^{85}Kr , ^{133}Xe) in cryogenic traps. The furnace system will be installed and operated in the HFEF main hot cell by FY10. INL is also developing and installing a pneumatic transfer system for automated insertion of samples into the core of the NRAD TRIGA reactor at the HFEF. This “rabbit” system will allow samples to be shuttled to and from the TRIGA core from the HFEF Decontamination Cell, enabling irradiated fuel samples to be reactivated in the core for various experimental needs.

The INL Advanced Test Reactor (ATR), located at the Reactor Technology Complex, is the highest power research reactor operating in the United States and is designed to evaluate the effects of intense neutron and gamma radiation on material samples, especially nuclear fuels. The ATR has large-volume, high-flux test locations for irradiation of fuel, reactor materials and components and a unique serpentine fuel arrangement that provides nine high-intensity neutron flux traps and 68 additional irradiation positions inside the reactor core reflector tank, which can each contain multiple experiments. Thirty-four more low-flux irradiation positions are located in the two capsule irradiation tanks outside the core. Neutron radiation effects from years of radiation in a power reactor can be duplicated in months or even weeks in the ATR. Powered with highly enriched uranium, the ATR has a maximum thermal power rating of 250 MWth with a maximum unperturbed thermal neutron flux rating of 1.0×10^{15} n/cm²·s.

The Transient Reactor Test Facility (TREAT) at INL was designed to test the behaviour of various fuels and structural materials under extreme or “transient” conditions, and now is in shutdown condition. TREAT is graphite-moderated air-cooled uranium oxide fuel reactor designed to allow simulations of severe accidents, including meltdown or fuel element specimen vaporisation, without damage to the reactor, and has excellent capabilities for producing prototypic power

transients and can produce sufficient energy in highly irradiated samples to simulate predicted RIA conditions. Slots through the core allow a high speed fast neutron hodoscope radiographic camera to record events taking place in the test position during the excursion. The TREAT fast-neutron hodoscope is, for most reactor safety tests, a key diagnostic instrument. By collimating and detecting fission neutrons emitted by experiment fuel specimens, the hodoscope provides time and spatial resolution of fuel motion during transients and in-place measurement of fuel distribution before and after an experiment. Although TREAT is currently shut down, it may be restarted for GNEP/AFCI fast reactor fuel testing, and it could be used if needed for gas-cooled reactor TRISO fuel transient testing.

- Other – The INL high-temperature test laboratory (HTTL) includes state-of-the-art high-temperature testing and examination equipment, such as a real-time X-ray imaging system, a laser welder for fabricating and examining test components, a test area with various DC power supplies, a stainless steel enclosure for testing radioactive materials, and a remote control room. Several systems are available for measuring material properties; including laser flash thermal diffusivity, pushrod dilatometer, and differential scanning calorimeter systems. In addition, several high-temperature (up to 3 000°C) furnaces are available for component testing. The HTTL has made it possible for INL to design and verify the performance of various heaters for simulating decay heat in prototypic corium, to investigate high-temperature materials interactions, and to advance INL's high-temperature instrumentation (e.g., thermocouple) development, fabrication, and evaluation capabilities, especially for ATR gas reactor fuel irradiation tests at high-temperatures (~ 1 250°C).

Argonne National Laboratory (ANL)

- Thermal Fluid – The ANL Natural Convection Shutdown Heat Removal Test Facility (NSTF) is an existing large-scale facility that was built to provide code validation and performance data for fast reactors. The NGNP programme is modifying it to obtain data for the gas reactor vessel/reactor cavity passive cooling systems such as the RCCS proposed for both the pebble-bed and prismatic designs. The NSTF will model the reactor cavity from the surface of the metal vessel to the insulated boundary wall with the RCCS air-cooled ducts or water-cooled standpipes inserted in-between and is 26.2m tall, with a 46cm×132cm test cross section, and a heated section length of 6.7m. Heater heat fluxes can reach 23.7 kW/m² and operating temperatures can reach up to 677°C, with axial power shaping.

The ANL reactor cavity cooling system (RCCS) separate effects facility experiment loops and components are planned to provide data on the phenomena that impact the performance of the RCCS. Separate effects issues include cavity heat transfer and natural convection, heat transfer in specific water stand-pipe or air duct geometry, natural convection flow transition and stability in parallel channel networks, two-phase mixture flashing and subcooled boiling behaviour in networks, and two-phase separation in storage tanks. The results could be made available for CFD and system code validation efforts. The ANL reactor cavity/building blow-down system separate effects facility experiment loops and components are available to provide data for the phenomena which occur in the cavity and the building during blow-down/leakage/relief-valve mass transfer from the primary system to the cavity or the building.

- Other – The ANL Confinement/Containment ZPR CELL5 is a large scale decommissioned zero power reactor cell with a nuclear-qualified ventilation system which can be used for confinement and/or containment building experiments. Experiments for the blow-down phase with helium/air mixing and graphite dust and aerosol releases into the building, natural convection circulation phase and air ingress phase coupling the mass/heat transfer between the building (ex-vessel) and the reactor vessel (in-vessel) can be performed. The ZPR CELL5 facility is rated for 0.4 MPa over-pressure and 45kg TNT equivalent, and is large (9m tall, 12mx 9m area) enough to accommodate a prototypic test.

Sandia National Laboratories (SNL)

- Thermal Fluid – SSNL) Advanced Energy Conversion Laboratory (AECL) is currently focused on power conversion experiments that support the development of integrated dynamic system models. The AECL has a 30 kWe Capstone C-30 gas-turbine unit, heater, chiller and associated plumbing. Future potential upgrades include increasing heater power to 100kWth, 1 150 K turbine inlet temperature to produce 30 kWe. A second SNL facility is under construction that has the potential for 1 MW electrical, 2 MW heating, 0.5 MW cooling and large space to accommodate additional loops. Although these systems are being used for Brayton-cycle critical CO₂ fast gas reactor systems, they could be used for helium gas-cooled thermal reactors as well.
- Fuel – The SNL Annular Core Research Reactor (ACRR) could be used to perform TRISO fuel transient testing for abnormal and/or accident conditions. The ACRR has been used for NRC severe accident phenomenology studies (fuel melting, fuel relocation, etc.) and testing of particle fuels and fuel elements for space nuclear thermal propulsion systems. The ACRR could be used to study transient behaviour of gas reactor fuels including performance limits and failure phenomena and mechanisms. SNL has used the ACRR facility to conduct studies on coated particle fuels, clad pellet fuels and carbide fuels for other reactor applications. The ACRR Transient Rod Withdrawal (TRW) operations mode can be used to increase power by tens of megawatts over large periods of time (e.g., 10 MW for 30-35 seconds) to produce for very realistic power ramps, specific power profiles, or rapid pulses that have widths over several seconds versus microseconds to simulate Reactivity Initiated Accident (RIA) events. The desired transient power level profile and achievable duration are inversely related but the overall achievable integrated energy release is about 300-350 MJ. The TRW mode operation of ACRR could be used to simulate various RIA scenarios including pebble bed repacking during earthquakes.

Oak Ridge National Laboratory (ORNL)

- Fuel – ORNL has an operational accident testing system dubbed the Core Conduction Cooldown Test Facility (CCCTF) that is similar to the INL furnace and has been used in previous HTGR fuel PIE campaigns. The CCCTF contains a fully programmable furnace facility with special gas sampling features with temperatures up to 2 000°C. ORNL's facilities for PIE of fuel include the Irradiated Fuel Examination Laboratory, which contains large hot cells for handling, disassembling, and performing various PIE activities on irradiated fuel and assemblies, and electron and optical microscopy on irradiated fuel specimens. ORNL also has analytical radiochemistry capabilities to support fuel PIE examination activities. The ORNL irradiated microsphere gamma analyzer (IMGA) hot cell has equipment designed for automated handling, gamma analysis and failure screening of individual HTGR coated particles.

The ORNL high flux isotope reactor (HFIR) can be used to irradiate small specimens of gas reactor fuel and graphite in a high neutron flux environment. HFIR is used for both fuels and materials irradiation and has the world's highest fast neutron flux capability, with thermal fluxes close to 1.8×10^{15} n/cm²·s at the core centerline and a fast neutron peak in the inner core centerline of 2.4×10^{15} n/cm²·s. The HFIR operates at 80 MW with exceptionally stable power levels and high thermal and fast neutron fluxes. In addition to the flux trap irradiation facility, several larger volume positions with for lower flux levels are available for fuel and materials irradiation. Access for instrumentation and gas communication are routine for all irradiation experiments, but space may not be available for independently monitoring isolated capsules in a multi-cell test train. Although the HFIR can accommodate a single fuel target length of 50 cm, only approximately 20 cm of the axial length has an averaged fast neutron flux greater than 1.0×10^{15} n/cm²·s, thus, the available target lengths may only be suitable for short fast reactor pins or targets but not long enough to accommodate a long fuel rod or TRISO compact test train with independently

controlled gas reactor fuel capsules. Furthermore, the intense high fast neutron flux may need to be greatly reduced with burnable fast neutron absorber filters so that the effects of an accelerated irradiation with high damage rates (i.e. displacements per atom, dpa) caused by the high fast-to-thermal-flux ratio can be mitigated. Additionally, the HFIR offers the possibility of hydraulically-driven (i.e. “rabbit”) tube irradiation for minutes to months of irradiation, so that previously irradiated TRISO fuel compacts could be reactivated for specific OECD/NEA safety testing needs.

- Other – The NGNP advanced gas reactor fuel program has developed unique state-of-the-art TRISO fuel fabrication and characterization laboratories at ORNL. These ORNL facilities include the: (a) Sol-Gel Laboratory for uranium particle fuel fabrication, (b) TRISO Particle Fuel Compacting Laboratory, (c) Particle Fuel Coating Laboratory, and (d) Fuel Characterization Laboratory.

The ORNL high-temperature materials laboratory has equipment to perform microstructural characterisation including a number of TEM, SEM, Auger, Atom Probe, etc. which are routinely used for irradiated materials. The equipment is either in open-access areas, or are in carefully controlled radiation work zoned areas. The ORNL LAMDA laboratory has a full range of thermophysical properties equipment, a large range of furnaces, test frames, thermal and physical property equipment, SEM, X-ray, X-ray tomography etc. The LAMDA laboratory is contained in a hot-lab with restricted access.

Brookhaven National laboratory (BNL)

- Other – BNL has facilities that are especially suitable for examining fuel issues: (a) a beamline at the National Synchrotron Light Source (NSLS) with an *in-situ* powder X-ray diffraction (XRD), (b) High Resolution Energy Dispersive X-ray Diffraction and Phase Mapping capabilities at the NSLS, (c) furnaces, specialty glass wear, and laboratory space associated with the production of Infiltrated Kernel Nuclear Fuel (IKNF) into graphite. The BNL Electron Microscopy Facility at the Center for Functional Nanomaterials (CFN) has state-of-the-art TEM and STEM for in-situ experiments and dynamic observations. BNL has hot cells with a nanometer level dilatometer, laser flash thermal conductivity measurements, an annealing furnace, and stress-strain and ductility measurement instruments.

University of California (UC) – Berkeley

- Thermal Fluid – The UC-Berkeley Thermal Hydraulics Laboratory operates the Scaled high-temperature Heat Transport (S-HT2) facility to simulate heat transfer and fluid mechanics in high-temperature reactor coolants (high pressure helium and liquid fluoride salts) at reduced temperature, pressure and power using simulant fluids (nitrogen and heat transfer oil). These experiments are scaled to match Prandtl, Reynolds, Froude and Grashof numbers simultaneously, for geometries of interest to high-temperature reactor applications. The S-HT2 facility can operate at powers up to 10 kW, which is equivalent to 0.5 MW of power input into the prototypical heat transfer fluid. Currently the S-HT2 facility is used for separate effects test experiments to study mixed convection heat transfer in vertical heated cylindrical channels.

Massachusetts Institute of Technology (MIT)

- Fuel – MIT has a 5-MW research reactor and has extensive experience in the conduct of in-reactor experiments at high-temperature gas reactor conditions. In addition, MIT has facilities for irradiation of fuel and graphite at temperatures up to 1 400°C.

- Other – MIT has high-temperature furnaces that could be used for diffusion studies in their H. H. Uhlig Corrosion Laboratory (operated jointly by the Nuclear Science and Engineering and Materials Science and Engineering Departments). The facilities in this laboratory can be used for the study of diffusion and chemical reactions in fuel materials at temperatures up to 1 800°C.

Oregon State University (OSU)

- Thermal Fluid – OSU maintains and operates the multi-application small light water reactor (MASLWR) facility, which is capable of conducting gas-cooled reactor natural circulation studies up to 8 MPa and 565 K.

Also, OSU is leading a consortium of University researchers in the development of a scaled integral test facility for gas-cooled reactors. The high temperature test facility (HTTF) is currently in its conceptual design phase, and is intended to provide high-temperature and simulated depressurised conduction cool-down data and can be configured for either pebble bed or prismatic core gas-cooled reactors. In addition, it may be possible to obtain limited data for pressurised conduction cool-down events. The facility and its instrumentation are being planned to provide data for several important gas-cooled reactor processes.

General Atomics (GA)

- Thermal Fluid – General Atomics (GA) has a test tower that has been used for gas-cooled reactor tests of control rods and drives, high-temperature thermal insulation, graphite block integrity, core earthquake response, fuel handling equipment, and thermal/hydraulic tests. The Test Tower facility could be adapted for small scale tests of this type.

Appendix 2

TERMS OF REFERENCE (TOR) OF THE TAREF TASK GROUP

Terms of reference for the CSNI Task Group on Advanced Reactor Experimental Facilities (TAREF)
REVISION of 4 November 2008

Title	Task on Advanced Reactor Experimental Facilities (TAREF) Infrastructure for safety research (focus on gas reactors and sodium fast reactors)
Objective	<p>The objectives of this activity are as follows:</p> <ol style="list-style-type: none"> 1. Provide an overview of identified facilities (existing or planned in TAREF member countries) suitable for performing safety research investigations relevant for gas-cooled reactors (GCR) and sodium fast reactors (SFR). 2. Review the Phenomenon Identification and Ranking Tables (PIRT) that have already been carried out for gas reactors in order to identify important safety issues. 3. Identify safety issues relevant for sodium fast reactor (recognising different designs). 4. Propose a strategy for an efficient utilisation of facility and resources for meeting short and long term safety requirements unique to GCR and SFR.
Scope	<p>The tasks to be performed are as follows:</p> <ul style="list-style-type: none"> • Compile a questionnaire regarding: a) Facilities that are suitable for experimental studies on gas-cooled reactor safety; b) Facilities that are suitable for experimental studies on sodium cooled reactor safety. • Examine the PIRT that are available for gas reactor systems³ and, based on the questionnaire responses and on the PIRT outcome, evaluate the options that can be recommended to CSNI for facility utilisation in safety domains through international undertakings. This is envisaged to require one or two meetings of the sub-task dedicated to gas reactors. • Identify the issues that are relevant for sodium reactor safety. This is expected to require three meetings of the subtask dedicated to sodium reactors. • Based on the questionnaire responses and on the safety issue identification performed for sodium reactors, evaluate the options that can be recommended to CSNI for facility utilisation in safety domains through international undertakings. This is envisaged to require one additional meeting of the sub-task dedicated to sodium reactors.
Safety significance	Advanced reactors incorporate design features, materials and safety provisions that are likely to require exploratory experiments, verifications and confirmatory tests. For this, an adequate facility and expertise infrastructure will be needed, in support of safety evaluation.

3. The USNRC has recently conducted a PIRT on gas reactor systems, and will make it available to the Task Group.

	A strategy for an optimal development and utilisation of such infrastructure is key for producing the necessary data in a timely and efficient manner, as required for safety assessments.
Expected Outputs	Two reports (to CSNI and CNRA), one for gas reactors and one for sodium reactors, identifying: a) Facilities relevant for safety research on identified safety issues; b) Recommendations on strategy for facility and expertise utilisation, e.g. on facilities and programmes needed at international level in support of safety assessments.
Safety Issues and Topics covered	<ul style="list-style-type: none"> • New concepts of operation • New risk perspective and safety requirements • Fuel and fuel cycle safety • New materials and fabrication technologies • Experimental facility loss (or need, in this case) • Transparent technical basis for safety assessment
Schedule/Milestones	<ul style="list-style-type: none"> • Develop the questionnaires and receive responses in the first half of 2008 • On gas reactor facilities, produce an outline of the report content by end of 2008 and the final report by June 2009 • For sodium reactor facilities, identify relevant safety issues and produce the final report by June 2010
Lead Organisation	<ul style="list-style-type: none"> • USNRC for gas reactor systems • IRSN for sodium reactor systems
Participant Organisations	Countries having advanced reactor programmes or large facilities suitable for gas reactor and sodium reactor studies, or countries that can contribute to the discussions on advanced reactor safety assessments are expected to participate.
Resources	<ul style="list-style-type: none"> • Approximately 1.5-2 man-years for the part related to gas reactors • Approximately 3-3.5 man-years for the part related to sodium reactors
Interaction with Others	<ul style="list-style-type: none"> • WGAMA on fluid dynamics and accident issues • WGFS on fuel issues • WGIAGE on structural materials issues
Approval by CSNI	Approved at the CSNI Meeting in December 2007

Appendix 3

QUICK SUMMARY OF THE TAREF MEETINGS – CGR PART

First meeting of the TAREF Task Group *OECD Headquarters, Paris, 3-5 November 2008*

Quick Summary

1. The terms of reference of the TAREF group were revised. Changes did not alter the substance of the task, except for what concerns the definition of the issues for sodium reactors, which would be based on discussions within the group rather than on a PIRT. The modified text was circulated at the meeting and is in the CD-R than was distributed at the meeting. The NEA Secretariat will circulate the modified text to the CSNI PRG and Bureau.
2. The reports (one for GCR and one for SFR) will be organised in four chapters as follows:
Executive summary
 1. Introduction
 2. Overview of GCR designs (or SFR designs)
 3. Technical issues and associated facilities
 - Technical areas
 - Issues pertaining each technical area
 - Facilities vs. issues
 4. Conclusions and recommendations
3. For the GCR report, Messrs. Iyoku and Austregesilo will in co-ordination with the NEA secretariat assemble the Chapter 1 – Introduction, which is to incorporate the terms of reference (background, purpose, objectives, scope etc), approach and organisation of the report. Less than 5 pages are expected. To be finalised and circulated to members by 15 January 2009.
4. The GCR reactor designs envisaged include HTR and VHTR (both pebble bed and prismatic design), as well as GFR. It was agreed that although designs differ from each other, the technical Areas are broad enough to cover all designs. The issues are to address the envisaged designs. Messrs. Dong and Renault agreed to write Chapter 2 – Overview of GCR designs. The overview given in Volume 1 of the NRC PIRT constitutes a very good start for the above, but a section on GFR will be needed (Mr. Renault). In total, 6-10 pages are foreseen. To be finalised and circulated to members by 15 January 2009.
5. For GCR, the technical Areas were identified consistently with the NRC PIRT, except for that regarding the hydrogen production – plant operation interaction. The areas are as follows:
 - a. accident analysis ant thermal-fluids (includes neutronics);
 - b. fission product transport;
 - c. high-temperature (metallic) materials;
 - d. graphite and ceramics;
 - e. TRISO fuel.

6. For GCR, Chapter 3 will include an introduction of ~1 page for each of the above technical areas and a set of typically 5-6 issues for each technical area. These issues correspond to those identified to be of high importance/low to medium knowledge in the NRC PIRT. Each issue should be accompanied with a “description” (4-10 lines) explaining the phenomena involved and the safety implication. An indication can be given as to whether there is adequate ongoing work covering the issue in question. The USNRC will provide the above (introduction of the technical areas and issues description/technical area) and circulate it to members by end of December 2008.
7. For GCR, members will provide – for each of the identified issues – the related facility that is deemed appropriate to address the issue in question. The information is to be provided according to the following template before the end of January 2009.

Issue	Facility	Availability	Capabilities
1	AAAA	Operating, available from...	Max three lines with most important characteristics
2	BBBB	Currently available	
	CCCC	Planned for operation in...	
3	DDDD		

8. For each of the GCR facilities proposed, members should provide a ½ page text (no figures) providing the information that the proposer believes is most appropriate (in- or out-of-reactor, operating range description of the test section, type of testing, instrumentation, current status and availability, uniqueness, links to appropriate web site). Members should provide this information by end of January 2009 (independent from point 7). In doing this, contributors should help addressing reasonable size facilities, considering grouping for clusters of small facilities.
9. The next TAREF meeting is scheduled for 2-4 March 2009 in Paris, starting at noon of the first day and finishing at noon of the last day. A small pre-meeting might be considered for the morning of 2nd March. The main focus of the meeting would be:
 - a. For SFR, in-depth discussion on the issues/description (see point 10) and description of facilities proposed (point 11).
 - b. For GCR, review of the material assembled for Chapters 1, 2 and 3 (points 2 to 7), review the description of facilities (point 11) and discussion on conclusions and recommendations.
 Considering the schedule for reporting to CSNI, a small follow-on meeting might be considered for the GCR, possibly in conjunction with the CSNI-PRG meeting (28-29 April 2009).

Agenda of First Meeting

- | | |
|------------------------|---|
| General | <ol style="list-style-type: none">1. Opening2. Election of Task Chairpersons3. Adoption of the agenda4. Discussion and approval of Terms of Reference5. Overall scope and intended schedule6. Group output, content of final report7. Working plans for group meetings to complete work scope – GCRs and SFRs |
| Gas reactors | <ol style="list-style-type: none">8. Overview of safety research in TAREF countries9. Overview of PIRT10. Overview of questionnaire11. Facilities for resolution of safety issues (current and planned)12. Approach to set priority13. Working plan and preparations for next meeting |
| Sodium reactors | <ol style="list-style-type: none">14. Overview of safety research in TAREF countries15. Approach to definition of safety issues<ul style="list-style-type: none">– PIRT approach– SFEAR approach16. Overview of questionnaire17. Facilities for resolution of safety issues<ul style="list-style-type: none">– Current– Planned18. Working plan and preparations for next meeting19. Closure, date and place of next meeting |

Second meeting of the TAREF Task Group
OECD Headquarters, Paris, 2-4 March 2009

Quick Summary

1. All action items from the previous meeting have been satisfactorily addressed. In particular, members have been very active in providing the requested material. Some of the information received needed some adjustment/completion, which to an appreciable extent was done during the meeting. It was agreed that the available information was adequate for the purpose of completing the task on GCR and for preparing the SFR discussion.
2. As agreed at the previous meeting, the intended schedule is to complete the GCR report in time for the CSNI June 2009 meeting. The SFR report should be finalised one year later, i.e. in June 2010. The main purpose of the meeting was to develop near, medium and long-term recommendations for CSNI on GCR, and to discuss and bring forward the set of safety issues related to SFR.

GCR Task

3. Fuel handling will not be included in the GCR list of issues.
4. Chapter 1 (Introduction) and Chapter 2 (Outline of Reference GCR) were reviewed in detail. The revised version will be communicated shortly after the meeting.
5. Regarding Chapter 3, it was agreed that:
 - a. The technical area on graphite will be denominated “Graphite and ceramics”, the one originally called TRISO Fuel will be denominated “Fuel”.
 - b. France/CEA has requested some additions in the issue list. The revised set of issues will be communicated to members shortly after the meeting.
 - c. NRC will revise the current version of Chapter 3, correcting editorial errors, acronyms etc.
 - d. Apart from the above changes, the Group agreed that the Chapter 3 text is acceptable.
6. The Group agreed on the main criteria for priority setting, which is to be based on the following items [High, Medium or Low (H, M, L) for each item]:
 - a. Relevance of the facility to cover a specific issue.
 - b. Uniqueness (e.g. one of a kind for in-pile testing).
 - c. Availability for a potential programme addressing the issue.
 - d. Readiness (e.g., staff available to run it).
 - e. Operating cost (<0.3, 0.3-1, >1M\$), or construction cost (<0.5, 0.5-2, >2M\$).
7. TAREF members that had proposed facilities were requested to characterise their proposed facilities in relation to the above criteria. Based on this, the Group recommendations for CSNI were developed. These recommendations are given in Appendix 1.
8. It was agreed that all facilities that had been proposed will be included in the report, both in Chapter 3 and in the Appendix. It was also agreed that the overall table with the highest ranked facilities would be included in the report, but that all details of the ranking would be omitted.

9. The next steps for finalising the GCR report are as follows:
 - a. *Chapter 1 and 2:* The NEA secretariat issues the revised Chapter 1 and 2 based on the Group discussion
 - b. *Chapter 3:* The NEA secretariat completes the list of issues and description that in Chapter 3. CEA will help with the description of the GFR issues. The NRC will revise Chapter 3 in terms of language, acronyms etc.
 - c. *Chapter 4 and Executive Summary:* The GCR Chair will assemble the Chapter 4, Summary and recommendations based on the meeting outcome – and the Executive Summary. The Executive Summary may well be more or less the same as Chapter 4.
 - d. *Appendix:* The NEA secretariat will interact with TAREF members to finalise the facility description. It was also agreed to include the TAREF Terms of Reference, the Group composition (and possibly the meeting summaries) in an additional appendix.
 - e. Item a., b. and c. above should be completed by end of March 2009, in time for sending it to CSNI-PRG, which will meet at end of April. Item d. should be finished by end of April.

GCR Recommendations

1. The TAREF task proved to be a useful exercise for gathering consensus on the technical areas and issues related to the safety of HTR and GFR systems, as well as for identifying a number of facilities that are or will become available in OECD member countries for supporting GCR safety research.
2. Existing facilities and facilities that are being constructed or planned in member countries cover all technical areas of concern and most of the safety issues identified in these areas. Hence, there is no apparent need for CSNI for undertaking specific actions oriented towards the development or build-up of a facility infrastructure (beyond what is currently planned in member countries).
3. Based on the responses received, the following facilities were among the most high ranked:

TAREF GCR Summary Ratings

	Accident and thermal fluids	Fission product transport	High-temperature materials	Graphite and ceramics	Fuel
Czech Republic		HTHL	HTHL	HTHL	
France	HEDYT ENIGMA	MERARG		HEDYT	PLINIUS
Germany	HELOKA A2	THAI	High Power Laser Lab		
Italy	HE-FUS3				
Japan	HTTR	HTTR	HTTR		
USA		ATR	ORNL materials lab. INL High Temp Test Lab	MIT Reactor HFIR	ACRR ATR MIT Reactor

For the longer term (2020 and beyond), the French GFR demonstration reactor ALLEGRO should also be considered.

4. The Japanese HTTR constitutes a unique resource in that it is the only experimental high-temperature gas reactor facility available in the OECD countries context. It is a graphite moderated, helium cooled reactor that can reach temperature as high as 1 600°C in some transient conditions. The experiments planned by JAEA to study effects of RCCS performance reduction are highly relevant for HTR safety assessments. The HTTR is also suitable for neutronics, fission product release and graphite dust issues related to prismatic fuel arrangements. Actions should be taken to develop an international programme centred on the HTTR capabilities and focused on the safety issues identified in the present task.

5. The Czech loop HTHL offers the opportunity to host separate effect tests carried out both out of pile and in-pile, hence offering the flexibility to address studies in which the combined effect of high-temperature gas environment and radiation are of relevance, such as for instance on fission product transport or high-temperature materials.
6. The HTTR and the HTHL plans are suitable with near term initiatives, i.e. for proposals that could result in defining an experimental programme in a 1-2 years time frame perspective. Following current practice of the CSNI projects, this action depends on host country and facility initiative, as well as on co-operative support.
7. Relevant CSNI Working Groups should be encouraged to share modelling information and discuss modelling activities relevant for GCR safety, in order to help focus the potential test programmes and/or enhance the data utilisation for model developments.
8. The Working Group on Analyses and Management of Accidents (WGAMA) has the advanced reactor item on its agenda. In this context, an activity in the field of thermal fluid dynamics and fission product behaviour in gas reactor environment could be considered. For instance in the form of a state of the art assessment and/or of an international standard problem regarding GCR safety issues. This could among others help defining medium term initiatives (3-5 years time perspective) for an analytical or experimental joint international programme in specific areas of need.
9. The Working Group on Fuel Safety (WGFS) is currently considering a workshop on the safety aspects of advanced fuel designs to be held in 2010. It is recommended that the Group proceeds with the organisation of the Workshop, including a session dedicated to GCR fuel safety needs and a discussion on further medium term WGFS initiatives in the GCR fuel safety area.
10. Group on Integrity of Component and Structures (IAGE) should define plans for an activity in the area of GCR materials, aiming to assess the state of knowledge and define the data needs for safety assessments of high-temperature materials, graphite and ceramics, as well as options for obtaining such data through CSNI-driven international undertakings.
11. The French Commissariat à l'énergie atomique (CEA) is encouraged to keep the CSNI and relevant CSNI Working Group abreast with the GFR design developments and with the analytical and experimental developments to support such development, including proposals for specific experimental programmes where appropriate.
12. In particular, the CEA should provide updates related to their long-term plans for the GFR demonstration reactor (ALEGRO), which in the long term (approximately 10 years ahead) could constitute a focus for joint international efforts.
13. Finally, the CSNI is to consider means for an adequate level of exchange with CNRA regarding needs and initiatives in the GCR safety area.

Agenda of Second Meeting

General

1. Opening.
2. Adoption of the agenda.
3. Review of summary and actions from the previous meeting.
4. Expected outcome of the meeting.

Gas reactors

5. Recall of final report structure and task member contributions.
6. Status of Chapter 1: Introduction.
7. Status of Chapter 2: Overview of GCR designs.
8. Status of Chapter 3: Technical issues and associated facilities.
9. Descriptions of the technical areas.
10. Descriptions of the issues pertaining each technical area.
11. Facilities vs. issues.
12. Priority setting.
13. Next steps, tasks and schedule.
14. Members' ideas/suggestions for international undertakings.

Sodium reactors

15. Recall of (provisional) technical areas: Are changes needed?
16. In-depth discussion of technical issues in each area (SFEAR approach).
17. Way to finalise technical issues, tasks.
18. Discussion on facilities (based on partners information), relation to issues.
19. Priority setting.
20. Structure of Final Report, schedule.
21. Tasks allocation to produce the Final Report.
22. Next steps, tasks and schedule.
23. Members' ideas/suggestions for international undertakings.
24. Working plan and preparation of the next meeting.
25. Closure, date and place of the next meeting.

Appendix 4

LIST OF TAREF MEMBERS

Canada

Dr. Hussam KHARTABIL khartabh@aecl.ca

Czech Republic

Dr. Vaclav DOSTAL vaclav.dostal@fs.cvut.cz

Finland

Mr Timo MERISAARI timo.merisaari@lut.fi

FRANCE

M. Pascal ANZIEU pascal.anzieu@cea.fr
M. Daniel BLANC daniel.blanc@irsn.fr
Mr. Hervé CHALAYE herve.chalaye@Ms.
Ms. Joelle PAPIN joelle.papin@irsn.fr Chair (SFR Systems)
Dr. Claude RENAULT claude.renault@cea.fr
Dr. Daniele VERWAERDE daniele.verwaerde@edf.fr

Germany

Dr. Henrique AUSTREGESILO henrique.austregesilo@grs.de
Dr. Axel BREEST Axel.Breest@grs.de
Dr. Wolfgang HERING wolfgang.hering@irs.fzk.de
Prof. Dr. Antonio HURTADO antonio.hurtado@tu-dresden.de
Dr. Th. Walter TROMM walter.tromm@nuklear.fzk.de

Hungary

Mr. Ivan TÓTH tothi@aeki.kfki.hu

ITALY

Dr. Fosco BIANCHI fosco.bianchi@enea.it

Japan

Mr. Tatsuo IYOKU iyoku.tatsuo@jaea.go.jp
Mr. Yoshiharu TOBITA tobita.yoshiharu@jaea.go.jp
Dr. Taisuke YONOMOTO taisuke.yonomoto@cao.go.jp

Korea (Republic OF)

Dr. Yong Wan KIM ywkim@kaeri.re.kr
Mr. Young-Min KWON ymkwon@kaeri.re.kr
Dr. Won-Jae LEE wjlee@kaeri.re.kr
Dr. Joon-Eon YANG jeyang@kaeri.re.kr

