



SINDO8 (77) 119
CSNI - 30

Gesellschaft für Reaktorsicherheit (GRS) mbH

B. HÖLZER,* T. KANZLEITER,* F. STEINHOFF

SPECIFICATION OF OECD STANDARD PROBLEM
NO. 6

DETERMINATION OF WATER LEVEL AND PHASE
SEPARATION EFFECTS DURING THE INITIAL
BLOWDOWN PHASE

FEBRUARY 1977

*BATTELLE-INSTITUT e.V. FRANKFURT (MAIN)

CONTENTS

1	Purpose of standard problem	1
2	Experimental facility description	2
3	Experimental facility instrumentation	3
3.1	Pressures	4
3.2	Temperatures	5
3.3	Forces	6
3.4	Density and mass flow rate	7
3.5	Water level	7
4	Data acquisition system	8
5	Availability of experimental data	9
6	Specification of test conditions	9
6.1	Geometrical data	9
6.2	Initial conditions in the pressure vessel	10
6.3	Results to be calculated	10
6.4	Presentation of Results	11
	References	12
	Appendix	

1 PURPOSE OF STANDARD PROBLEM

Since 1967 an experimental research program has been performed at the BATTELLE-Institute in Frankfurt (Main) to study the discharge process after the rupture of a main coolant pipe in water-cooled reactors (PWR, BWR). This project is supported by the West German Ministry for Science and carried out in cooperation with German consultants and industrial firms. The research program is aimed at investigating the physical phenomena of the discharge process, checking the applicability of computer codes used in licensing process and getting better informations for further code improvement and development.

Out of the BATTELLE experiments the BWR-blowdown SWR-2R with a break orifice of $D = 64$ mm is proposed as a new CSNI-Standard Problem. The purpose of this Standard Problem should be the testing of the waterlevel and the discharge mass flow rate models in the blowdown codes in the initial phase of the blowdown (0 ./ . 3 s).

The following reasons encouraged us to propose the new Standard Problem and the experiment SWR-2R as its basis:

- a) Water level models are important parts of the blowdown codes. But up to now experiments with good water level measurements of the initial phase of the blowdown (water level rises up to break nozzle) have been rare for testing such models. Battelle has developed a special measuring technique and installed for BWR-experiments.
- b) Experiment SWR-2R seems to be suitable for testing of water level models, as the pressure vessel in the

upper part was not equipped with internals, which could influence the water level behaviour.

- c) Experiment SWR-2R offers also a good occasion to test the discharge flow models of the blowdown codes, because the improved drag body method for the determination of the discharge mass flow rate was already used for this experimental run.

2 EXPERIMENTAL FACILITY DESCRIPTION

The overall test facility layout is shown in fig. 1.

The layout consists of several parts:

- left down of fig. 1 the pressurizer, which is necessary to adjust the initial pressure for PWR-experiments,
- in the middle the pressure vessel with the electrical resistance heating of about 600 kW, which is necessary to adjust the stationary temperature distribution of the coolant (fully desalted water) in the vessel. The heating is switched off, when this distribution is reached
- right hand the supply loop with the heat exchanger and the pump. The valves between the pressure vessel and the supply loop are closed, when the initial conditions are adjusted.

The pressure vessel is mounted in a supporting frame work. The vessel has an inner diameter of 0.77 m, a volume of

5.2 m³ and a height of 11.19 m, which is almost the height of an original reactor vessel. Further geometrical values can be found in fig. 1 and 2. The vessel is designed for a maximum operating pressure of 140 bar and a temperature of 300 °C. The material of the vessel is ferritic steel plated with "Eutaloy". Numerous nozzles permit rupture to be simulated at six different levels.

The position of the discharge nozzle for run SWR-2R was level G in fig. 1 and 2. The geometry of the nozzle is figured in 3. The blowdown is initiated when the concave rupture disc is destroyed by the electrical ignition of a fuse. The rupture area is simulated by the orifice behind the rupture disc. For the experiment SWR-2R an orifice with a diameter of 64 mm was installed.

3 EXPERIMENTAL FACILITY INSTRUMENTATION

In the BWR experiments the following parameters were determined as a function of time:

- the static pressure at several positions of the vessel and the discharge nozzle,
- the temperature at several levels of the vessel and in the discharge nozzle,
- the horizontal force of reaction and the vertical force of the vessel,
- the density in the discharge nozzle determined from γ -absorption measurements,
- the mass flow rate in the discharge nozzle determined from the density results and force measurements,
- the water level in the pressure vessel

3.1 Pressures

The static pressures were measured at several levels of the pressure vessel (see figs. 2,5) and in the discharge nozzle.

The measuring points of the vessel:

level A	PS 060 BI MIT
B	PS 170 BI 000
	PS 170 BI 180
C	PS 380 BI 000
	PS 380 BI 180
E	PS 640 BI 000
	PS 640 BI 180
F	PS 780 BI 180
G	PS 999 BI 180

At these positions quartz pressure gauges were installed. These pressure gauges had a relative accuracy of 1 %.*)

Additional pressure gauges (see fig. 2) were installed on the top of the vessel (PL 1118 BS), and in the nozzle at the bottom (PL -67 AK). These gauges have a relative accuracy of 0.7 %. Position PM -67 BS is equipped with a manometer of 0.2 bar accuracy.

The measuring points of the discharge nozzle:

The different positions of the pressure gauges in the discharge nozzle are depicted in fig 4:

*) probable (gaussian 2 σ) error limits of the complete measuring cascade, but without influence of a temperature transient at the site of the gauge.

sectional view A-B : PS 999 BS 005
 PS 999 BS 001
 PS 999 BS 003
 C-D : PS 999 BS 010
 X : PS 999 BS 015
 PS 999 BS 016
 PS 999 BS 013
 PS 999 BS 017

For these position quartz gauges with a relative accuracy of 1 % were used. The accuracies of the pressure gauges are full scale values.

3.2 Temperatures

The temperatures were measured by two types of temperature gauges, the "slow resistance thermometers" (PT 100) with an accuracy of 1/3 DIN (about 1°C) and the "fast thermoelements" (Philips 0.25 mm) with a response time of 15 ms and an accuracy of 1/2 DIN (about 2°C).

The "slow resistance thermometers" were mainly installed to adjust the stationary temperature stratification in the water. The position of the "slow resistance thermometer" can be seen in fig. 2.

position A : TL 060 BIMIT - T1
 B : TL 170 BIMIT - T0
 C : TL 380 BI270 - T2
 E : TL 640 BI180 - T4
 F : TL 800 BI180 - T6

The transient temperatures were measured by the "fast thermoelements" at several levels of the vessel and in the discharge nozzle.

The positions of the temperature gauges can be found in figs. 4, 5.

levels in the vessel (fig. 5):

A : TS 060 BI MIT
B : TS 170 BI 000
 TS 170 BI 180
C : TS 380 BI 000
 TS 380 BI 180
E : TS 640 BI 000
 TS 640 BI 180
F : TS 780 BI 180
G : TS 999 BI 180

positions in the discharge nozzle (fig. 4):

sectional view A-B : TS 999 BS 006
 TS 999 BS 002
 TS 999 BS 004
 C-D : TS 999 BS 009

3.3 Forces

The horizontal force of reaction at level F (fig. 1) was measured by a spring-suspended load cell with 6 Hz eigenfrequency (position FH 780 BA 180 in fig. 2). The relative accuracy of this load cell was 1.5 % full scale. The loss in weight was measured by a load cell with 25 Hz eigenfrequency at the bottom of the vessel (pos. FV -67 BA MIT in fig. 2). The relative accuracy of this load cell was 1.7 %. Because of the eigenfrequencies the results of the load cell measurements were unusable for the first second of the blowdown.

3.4 Density and Mass Flow Rate

The density of mass flow rate in the discharge nozzle was determined from the results of the γ -absorption method.

The accuracy of these results is about 12 %.

The position of the two γ -sources and the scintillation detectors can be found in fig. 4.

sectional view C-D : DA 999 BS 012
DA 999 BS 010

The discharge mass flow rates were determined from the density results and the additional drag body measurements.

The position of the drag bodies is also given in fig. 4.

sectional view C-D : FD 999 BS 007
FD 999 BS 008

The accuracy of the mass flow rate results is estimated at 10 ./ . 15 %.

3.5 Water-Level

The time history of the water level was measured by a stalk equipped with electrical contacts. The position of this stalk is depicted in fig. 2. The electrical contacts were installed at many levels of the stalk. At the moment when the water level is wetting a contact, current can flow between the electrodes and produce electrical signals. These signals are registrated. The accuracy of the water level

results is influenced by heat extensions, but the mistakes are ± 2 cm/.

4 DATA ACQUISITION SYSTEM

The output signals of the transducers must first be conditioned and amplified to the input voltage level of the signal recording unit. Up to 120 signals with a bandwidth of 5 kHz have to be recorded on a wide-band 14-track analogue tape unit by means of a frequency multiplex system with nine carrier frequencies.

After the experiment, the data stored on the analogue tape are transmitted to the computer for processing and graphic representation. In processing the data, zero drift and errors in the amplification factor of the measuring cascade are corrected.

5 AVAILABILITY OF EXPERIMENTAL DATA

The proposed "Standard Problem" should be performed as an "open" one, because experiment SWR-2R was run in May 1976 and the results are already known to many persons. Further experiments without internals are not planned. The results of the measuring positions, discussed in chapter 3, are available to all participants of the Standard Problem.

6 SPECIFICATION OF TEST CONDITIONS

6.1 Geometrical Data

Experiment SWR-2R simulates the steam line rupture of a German boiling water reactor. The diameter of the sharp edged discharge orifice was 64 mm. The pressure vessel had no internals, except an electrical resistance heating, which was switched off, when the stationary thermal stratification was adjusted.

First important geometrical data can be taken out of figs. 1 - 5, and the detailed construction drawings of the vessel and the heating. It is proposed to take the corrected geometrical data of the vessel for 285 °C (see R 61 797 - 1403b).

6.2 Initial conditions in the pressure vessel

The initial conditions in the pressure vessel are briefly summarized:

- pressure $p_0 = 71.1$ bar pos. PM-67 BS (fig. 2)
- Temperature : $T_0 = 289.4$ °C pos. TL 170 BIMIT
 $T_1 = 285.5$ °C TL 060 BIMIT
 $T_2 = 289.5$ °C TL 380 BI 270
 $T_4 = 288.0$ °C TL 640 BI 180

In comparison to the saturation pressures the slow temperatures (TL) are a little too high (~ 3 °C).

- water level height : 7.07 m (hot water 285 °C)
- mass flow rates in the vessel can be assumed to be zero.
- additional informations about initial or boundary conditions can be taken out of the plots in the appendix.

6.3 Results to be calculated

Each participant of the Standard Problem should calculate the following results for the first 3 seconds of the blow-down:

- Pressure and temperature time histories in the vessel at the following levels (figs. 2, 5):

level	pressure	temperature
B	PS 170 BI 000	TS 170 BI 000
C	PS 380 BI 000	TS 380 BI 000
E	PS 640 BI 000	TS 640 BI 000
F	PS 780 BI 000	TS 780 BI 180
G	PS 999 BI 180	TS 999 BI 180

In comparison to the saturation pressures the "fast temperatures" (TS) are about 3 - 4 °C too low

- pressure and temperature history in the discharge nozzle (fig. 4):

PS 999 BS 011 TS 999 BS 009

- mass flow rate in the discharge nozzle (position of the drag bodies: see sectional view C-D in fig. 4)
- water level in the steam dome (position of the water level stalk: see fig. 2)

6.4 Presentation of Results

The calculated results should be represented in plots of the following form:

Length of X-axis for all plots:	25 cm
time range:	0 - 3.75 s
Length of Y-axis for all plots:	15 cm
pressure range:	50 - 80 bar
temperature:	150 - 300 °C
mass flow rate:	0 - 150 kg/s
water level:	6 - 12 m

REFERENCES

/1/

BATTELLE

Technischer Bericht BF - RS 0016B-32-7

Versuchsergebnisse vom Druckentlastungsvorgang beim Referenzversuch SWR-2R

Juli 1976

/2/

BATTELLE

Technischer Bericht BF - RS 0016B-33-1

Versuchsergebnisse zum Gemischspiegelverhalten in einem 11,2 m hohen Behälter ohne Einbauten nach einem Dampfleitungsbruch (Versuch SWR-2R)

März 1977

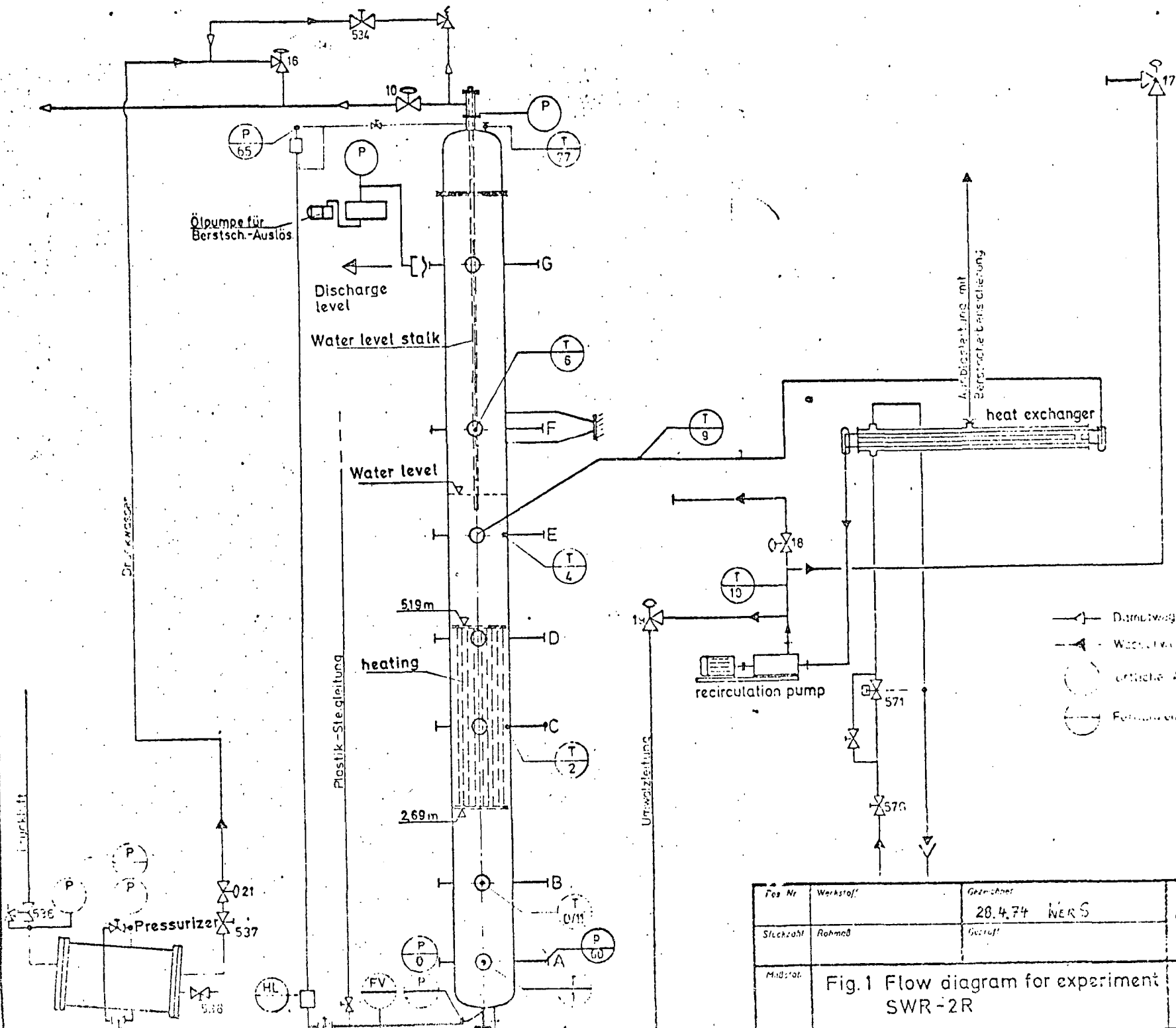

- Dampfweg
- Wasserweg
- örtliche Anzeige
- Fernanzeige

Fos Nr	Werkstoff	Gezeichnet	BATTELLE-INSTITUT ER FRANKFURT M. W.
Stichzahl	Rohmaß	28.4.74 WERS	
Modul		Geprüft	

Fig.1 Flow diagram for experiment SWR-2R

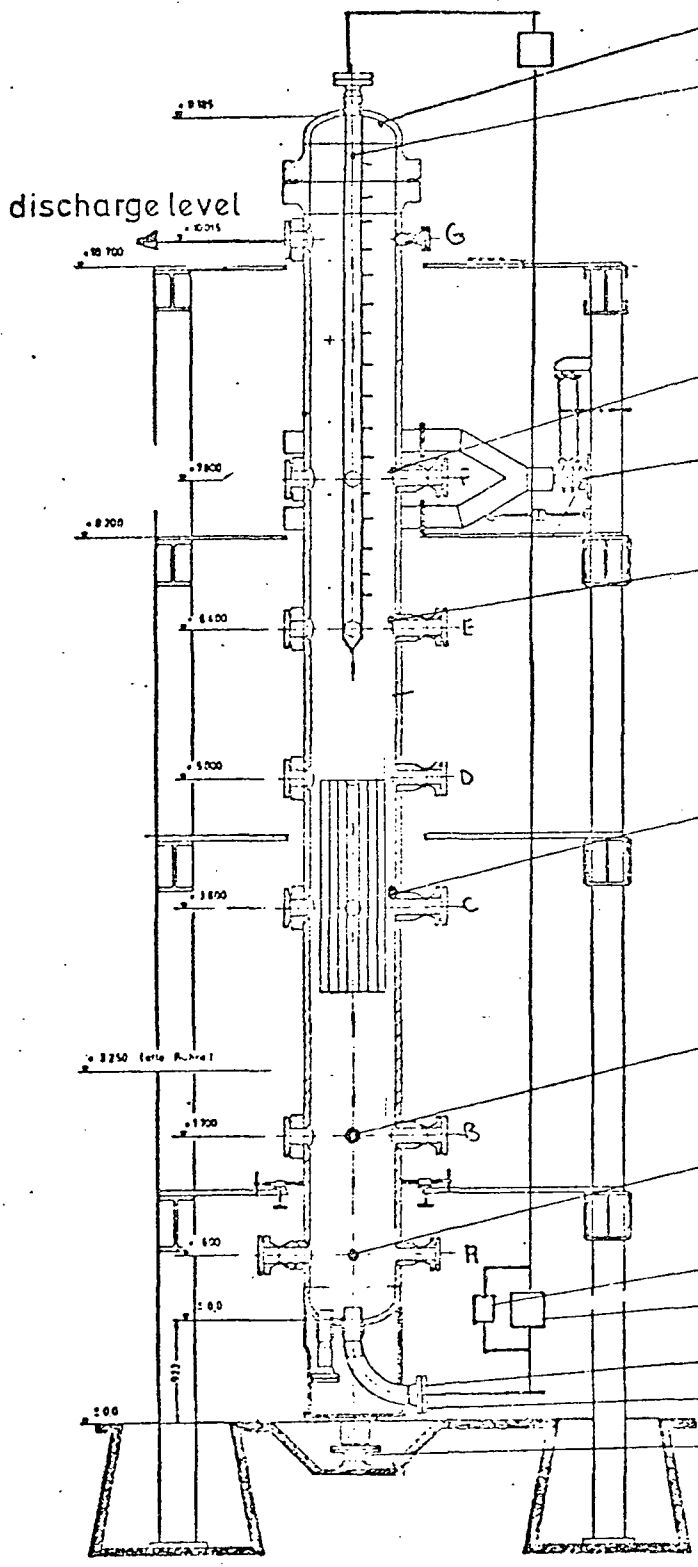

Meßstellenbezeichnung	M/K	M/K
PL 1118BS	5/3	115
Water level stalk	direkt	
TL 800BI180-T6	direkt	
FH 780BA 180	4/1	121
TL 640 BI 180-T4	direkt	
TL380BI270-T2	direkt	
TL 170BIMIT-T0	direkt	
TL 060BIMIT-T1	direkt	
HS-67/1118	1/2	116
HL-67/1118	direkt	
PL-67 AK	1/1	114
PM-67 BS	direkt	
FY-67 BAMIT	1/3	120

Fig. 2: Pressure vessel with supporting frame work

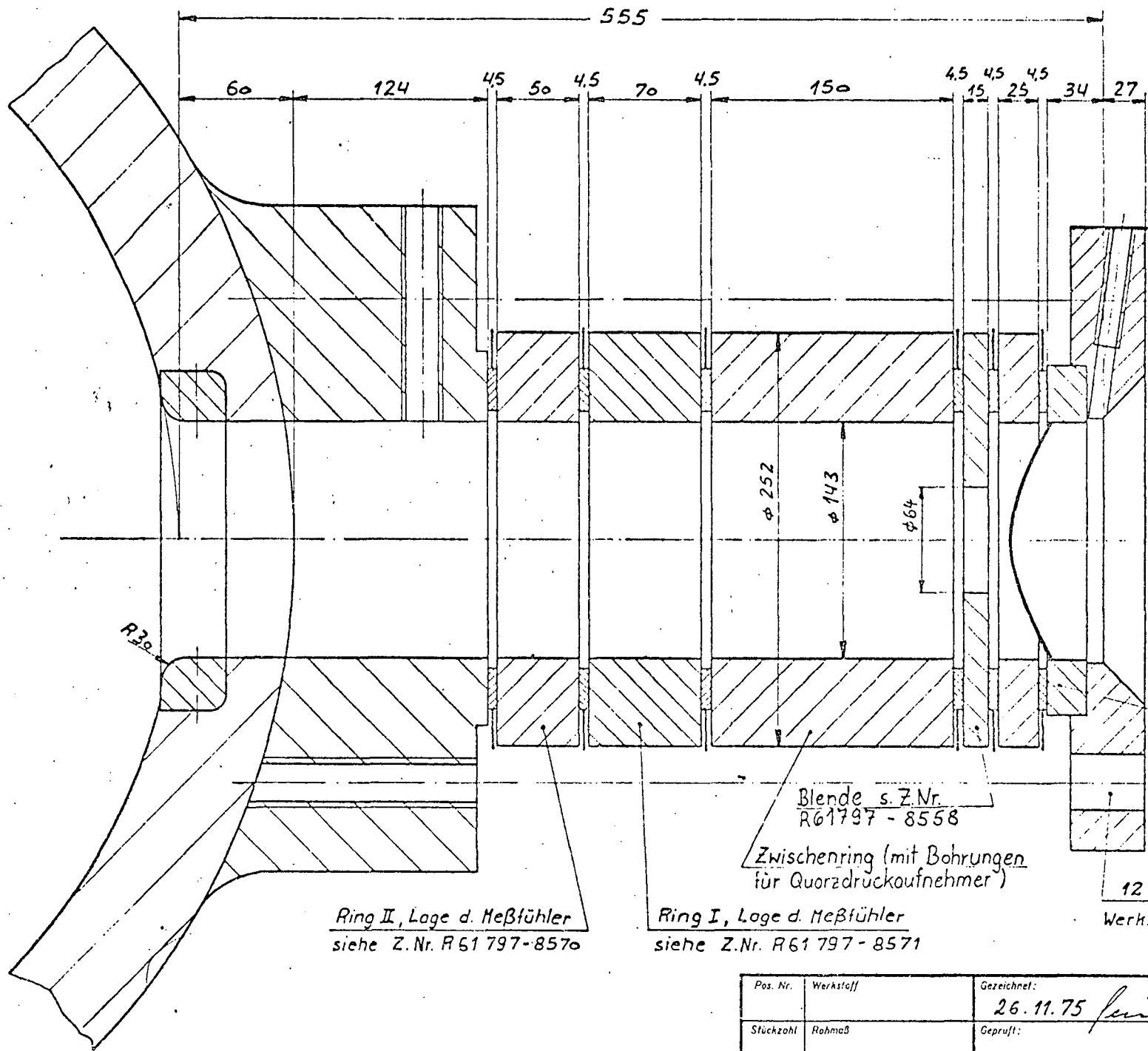

Umkehrberstsich. Typ BS-E
 Betriebsdruck: 7,5 atü
 Betriebstemp: 285 °C
 Berstdruck: 87,5 atü

Blende s. Z.Nr.
 R61797-8558

Zwischenring (mit Bohrungen
 für Quarzdruckaufnehmer)

12 x Schraubenbolzen M30 x 48 mm
 Werkst. 24Cr MoV55, Mu. aus 24Cr Mo5

Ring II, Loge d. Meßfühler
 siehe Z.Nr. R61797-8570

Ring I, Loge d. Meßfühler
 siehe Z.Nr. R61797-8571

Sämtliche vom vollentsalzten Wasser
 berührten Teile aus nichtrostenden Stahl

Pos. Nr.	Werkstoff	Gezeichnet:	BATTELLE-INSTITUT E.V. FRANKFURT M.-W 13
Stückzahl	Rohmaß	Geprüft:	
Mußstab			Zeichnungs-Nr.
1:2,5	Fig. 3: Discharge nozzle		R 61 797-8018 a

Meßstellenbezeichnung MK Kreis

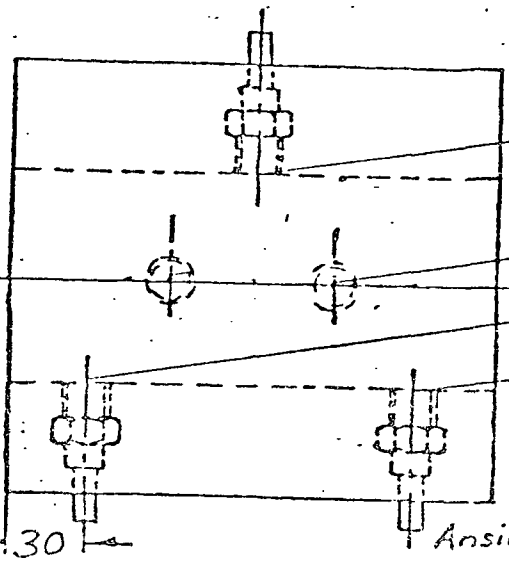
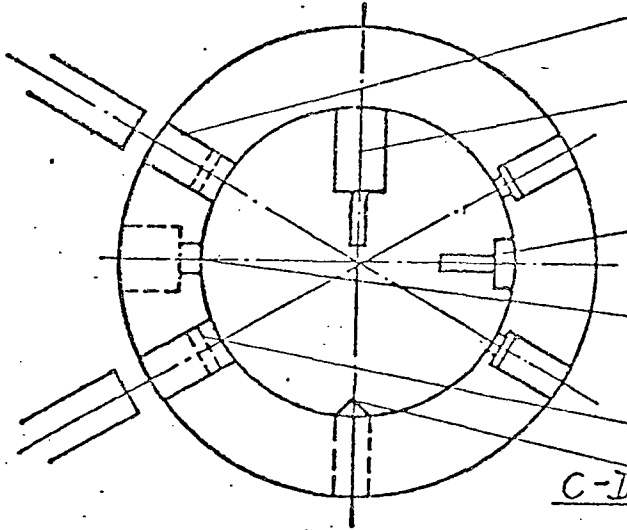
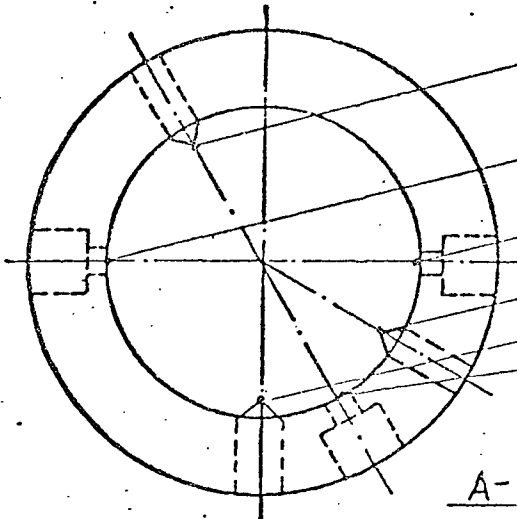
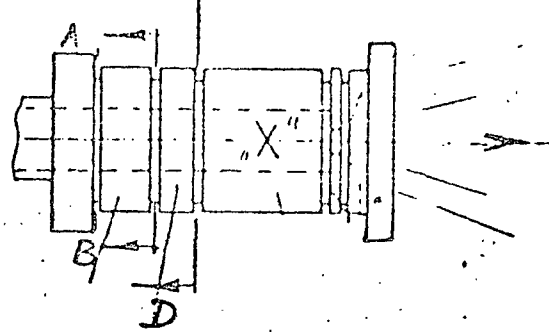

Meßstellenbezeichnung	MK	Kreis
TS 999 BS 006	4/17	110
PS 999 BS 005	5/15	92
PS 999 BS 001	5/13	90
TS 999 BS 002	4/15	108
TS 999 BS 004	4/16	109
PS 999 BS 003	5/14	91
DA 999 BS 012	4/30	119
FD 999 BS 007	5/1	112
FD 999 BS 008	5/2	113
PS 999 BS 011	5/16	93
DA 999 BS 010	4/29	118
TS 999 BS 009	4/18	111
PS 999 BS 015	5/19	96
PS 999 BS 016	5/20	97
PS 999 BS 013	5/17	94
PS 999 BS 017	5/21	98

Fig. 4: Measuring positions in the discharge nozzle

		Meßstellenbezeichnung	MK	Konrad
		PS 999 BI 180	4128	89
		TS 999 BI 180	4144	107
		PS 780 BI 180	4127	88
		TS 780 BI 180	4143	106
		PS 640 BI 180	3130	87
		TS 640 BI 180	3146	105
		PS 640 BI 000	3129	86
		TS 640 BI 000	3145	104
		PS 380 BI 180	2127	85
		TS 380 BI 180	2143	103
		PS 380 BI 000	2128	84
		TS 380 BI 000	2144	102
		PS 170 BI 180	1121	83
		TS 170 BI 180	1143	100
		PS 170 BI 000	1120	82
		TS 170 BI 000	1142	101
		PS 060 BI MIT	1119	81
		TS 060 BI MIT	1141	99
				

Fig. 5: Measuring positions in the vessel

APPENDIX

1. Plots of experimental results

PS 170 BI 000
TS 170 BI 000
PS 380 BI 000
TS 380 BI 000
PS 640 BI 000
TS 640 BI 000
PS 780 BI 180
TS 780 BI 180
PS 999 BI 180
TS 999 BI 180
PS 999 BS 011
TS 999 BS 009

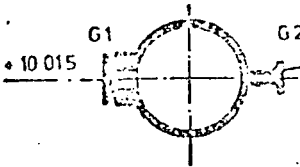
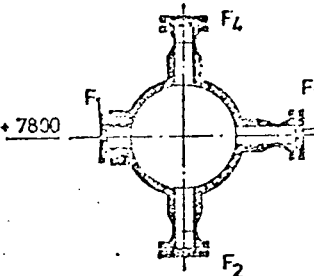
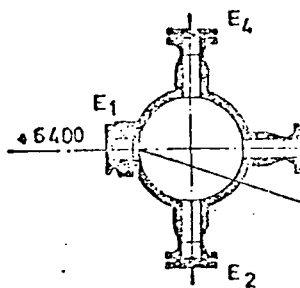
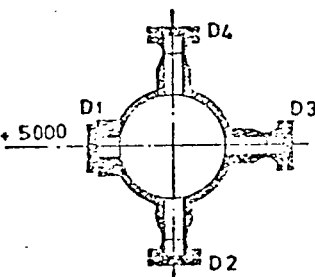
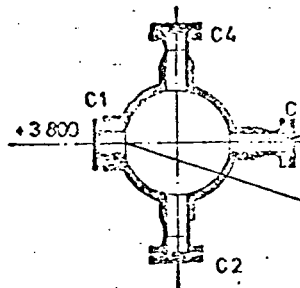
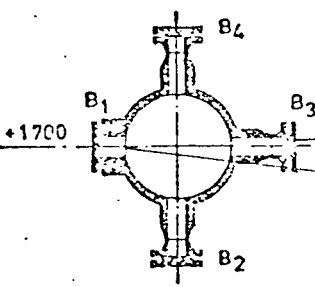
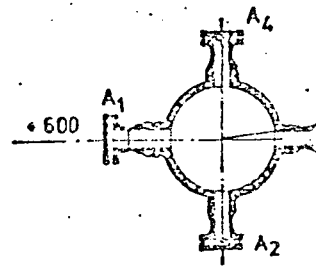
Water level in the vessel

Mass flow rate in the discharge nozzle

2. Additional drawings

Water level stalk in the pressure vessel (R 61 797-8007a)

Position of a crystal pressure transducer cooled by air

Pressure vessel (R 61 797-1403b)

Heating (R 61 797-2703)

PS170B1000-BAR

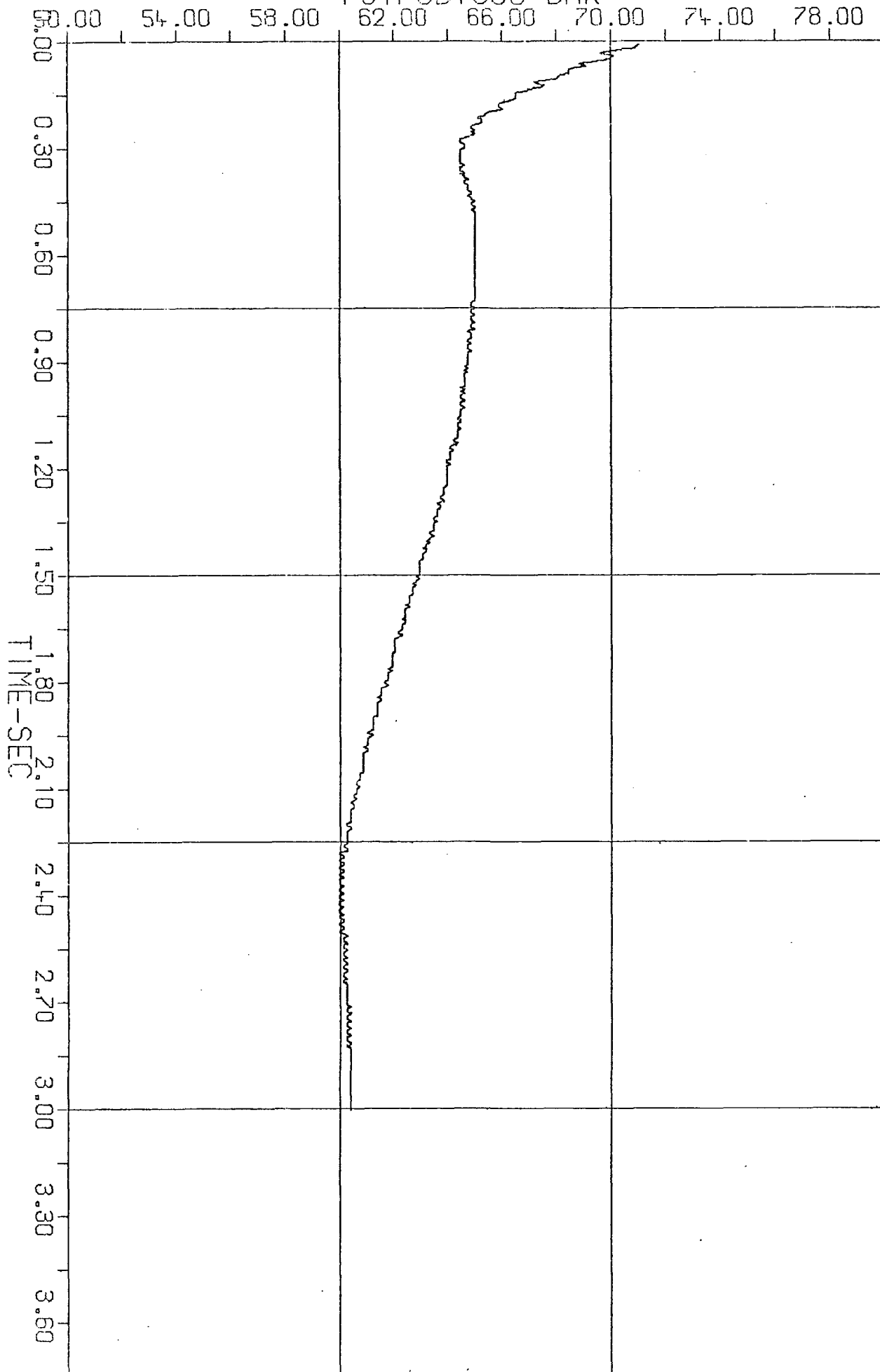

L R A - GARCHING

10-1 * TS170B1000-DEG.C

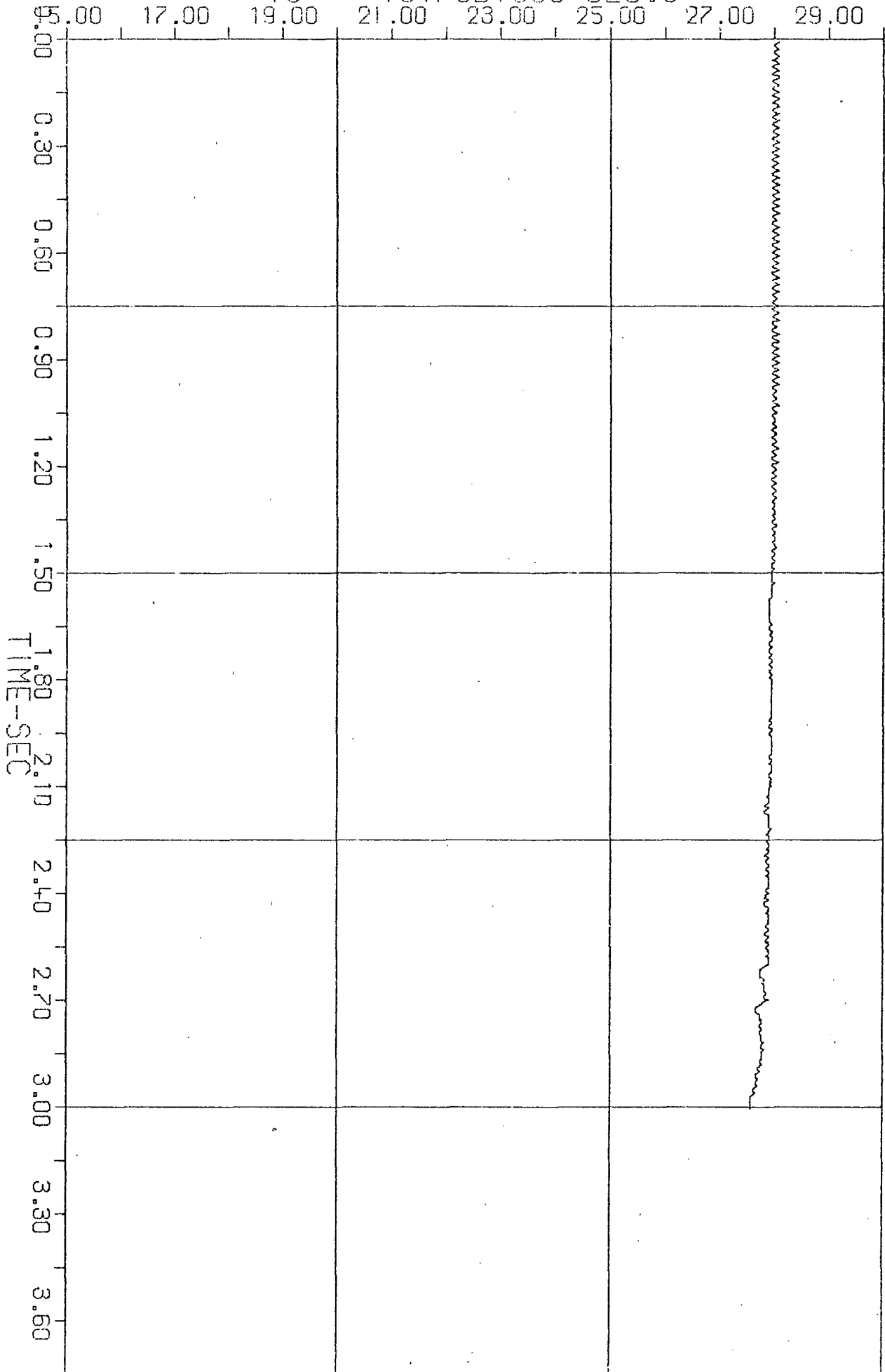

L R A - GARCHING

PS380B1000-BAR

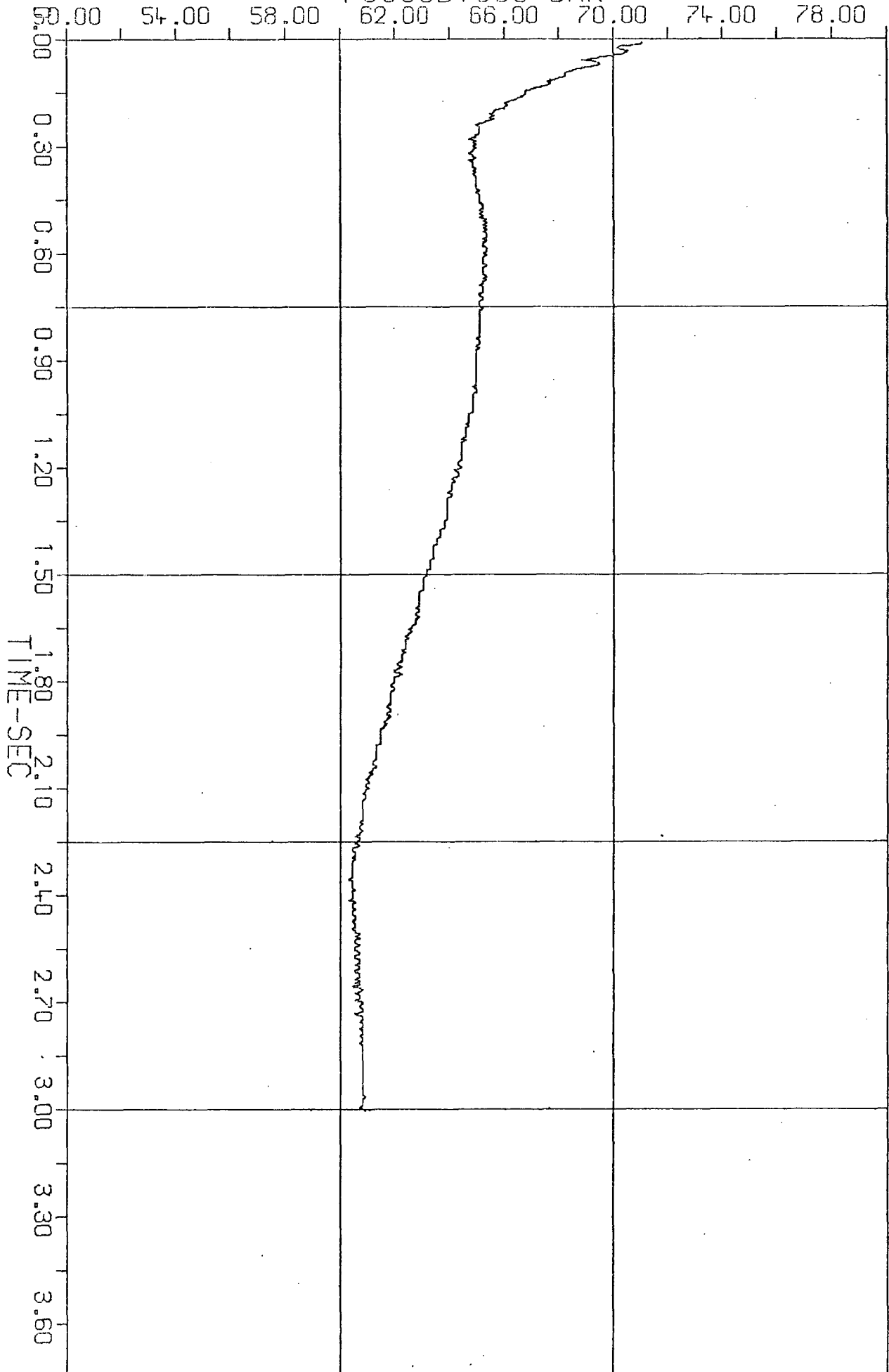

L R A - GARCHING

10⁻¹ * TS380B1000-DEG.C

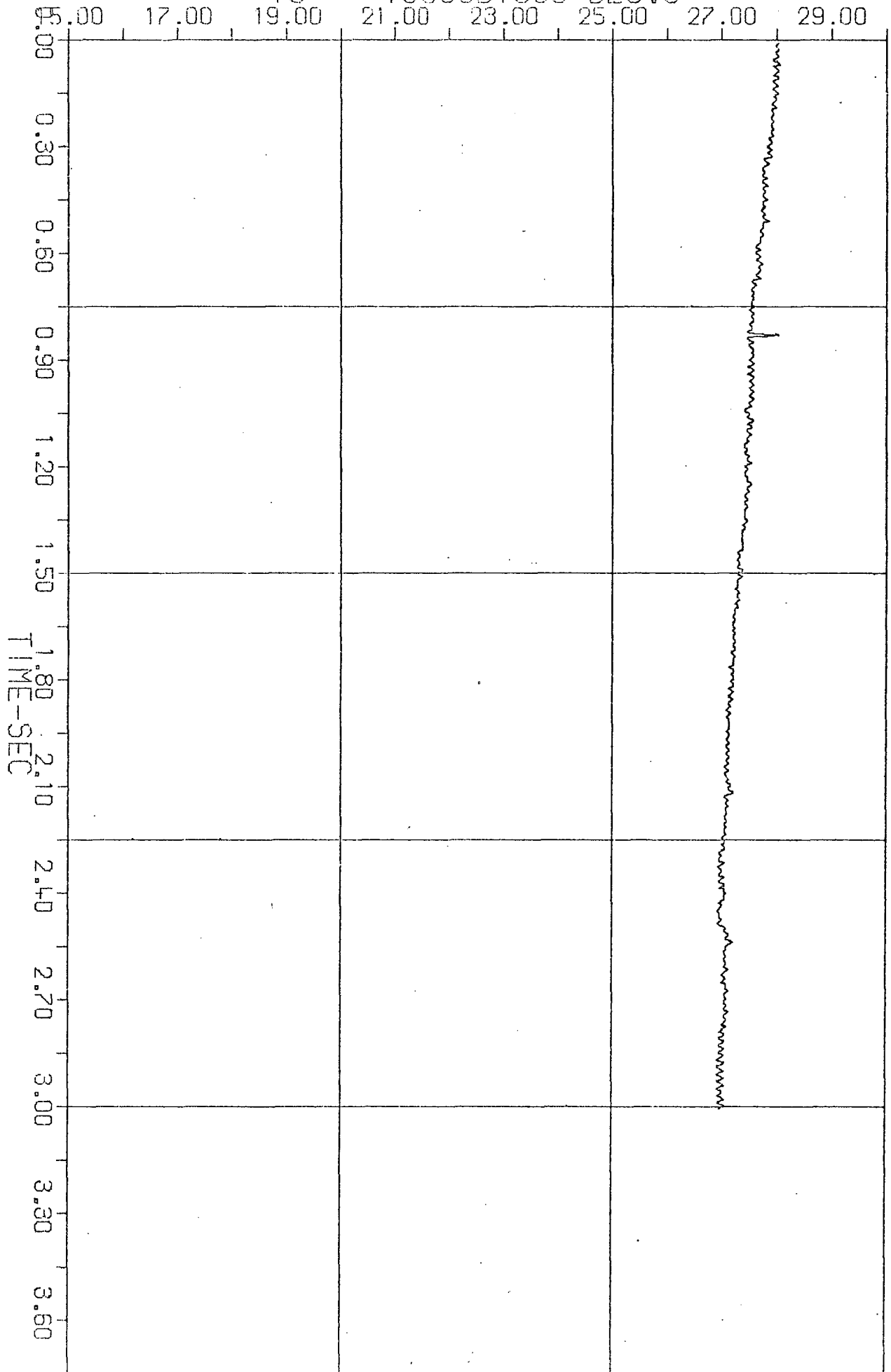

L R A - GARCHING

PS640B1000-BAR

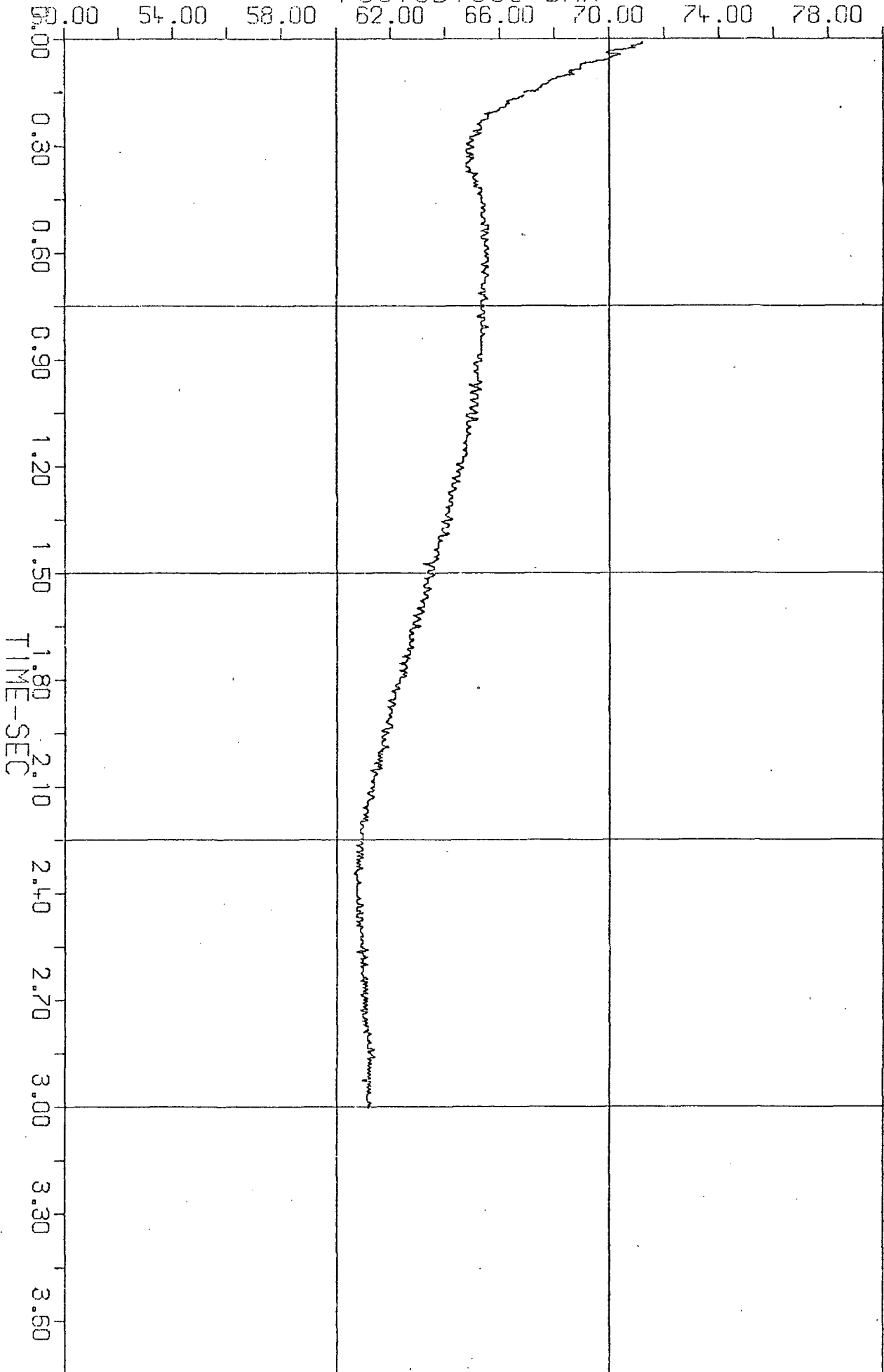

L R A - GARCHING

10-1 * TS640B1000-DEG.C

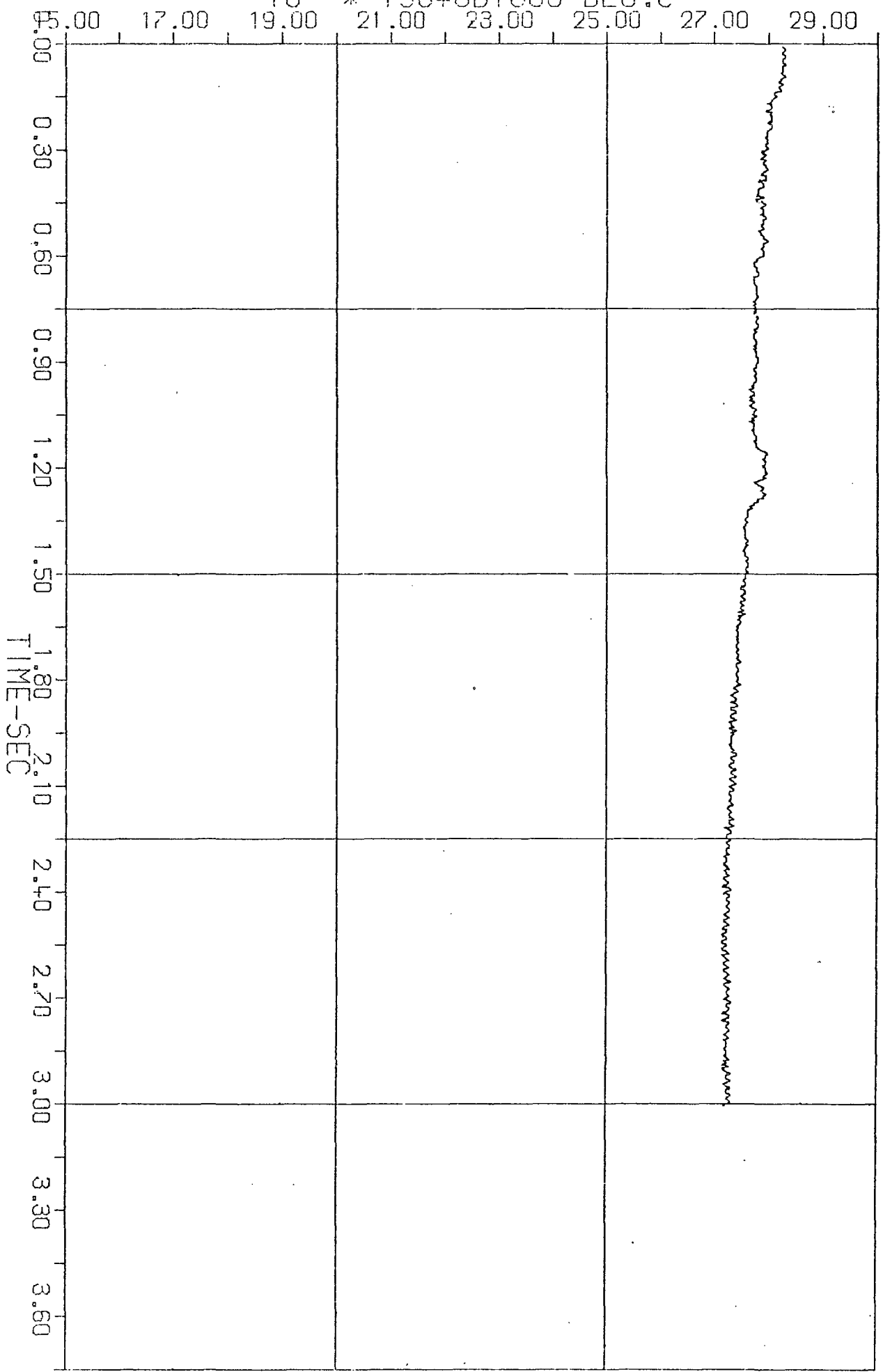

L R A - GARCHING

PS780B1180-BAR

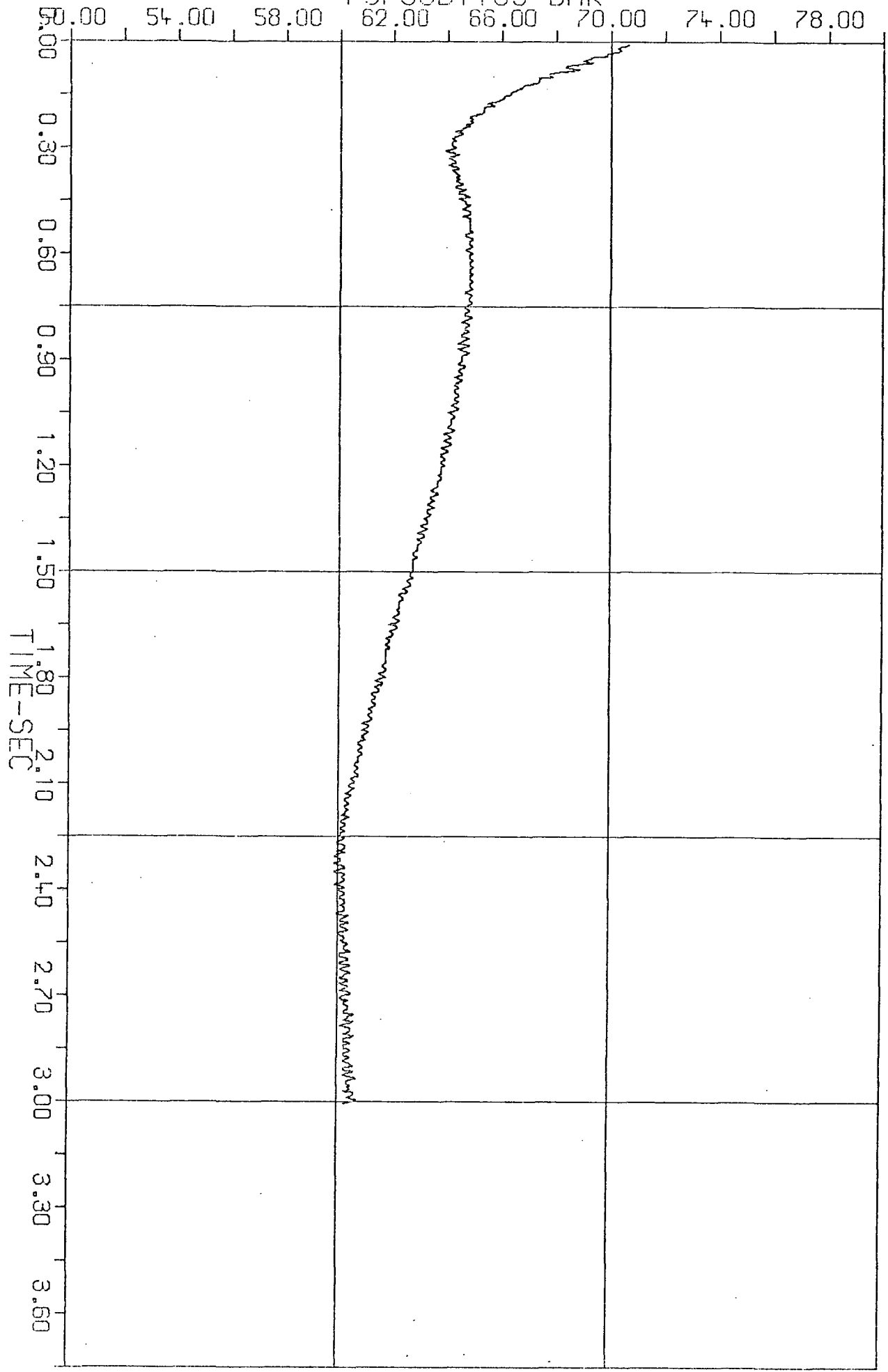

L R A - GARCHING

10-1 * TS780B1180-DEG.C

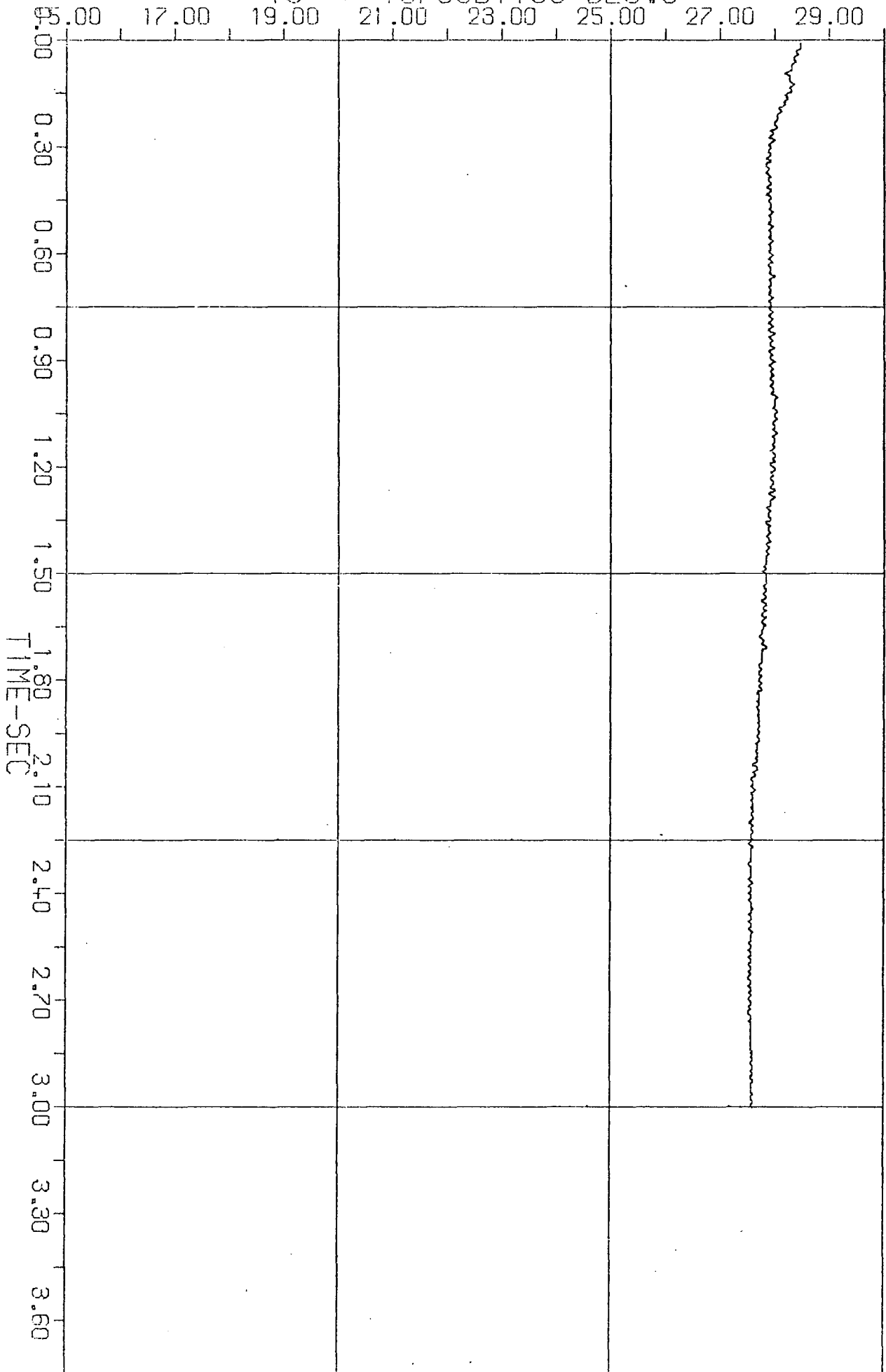

L R A - GARCHING

PS999B1180-BAR

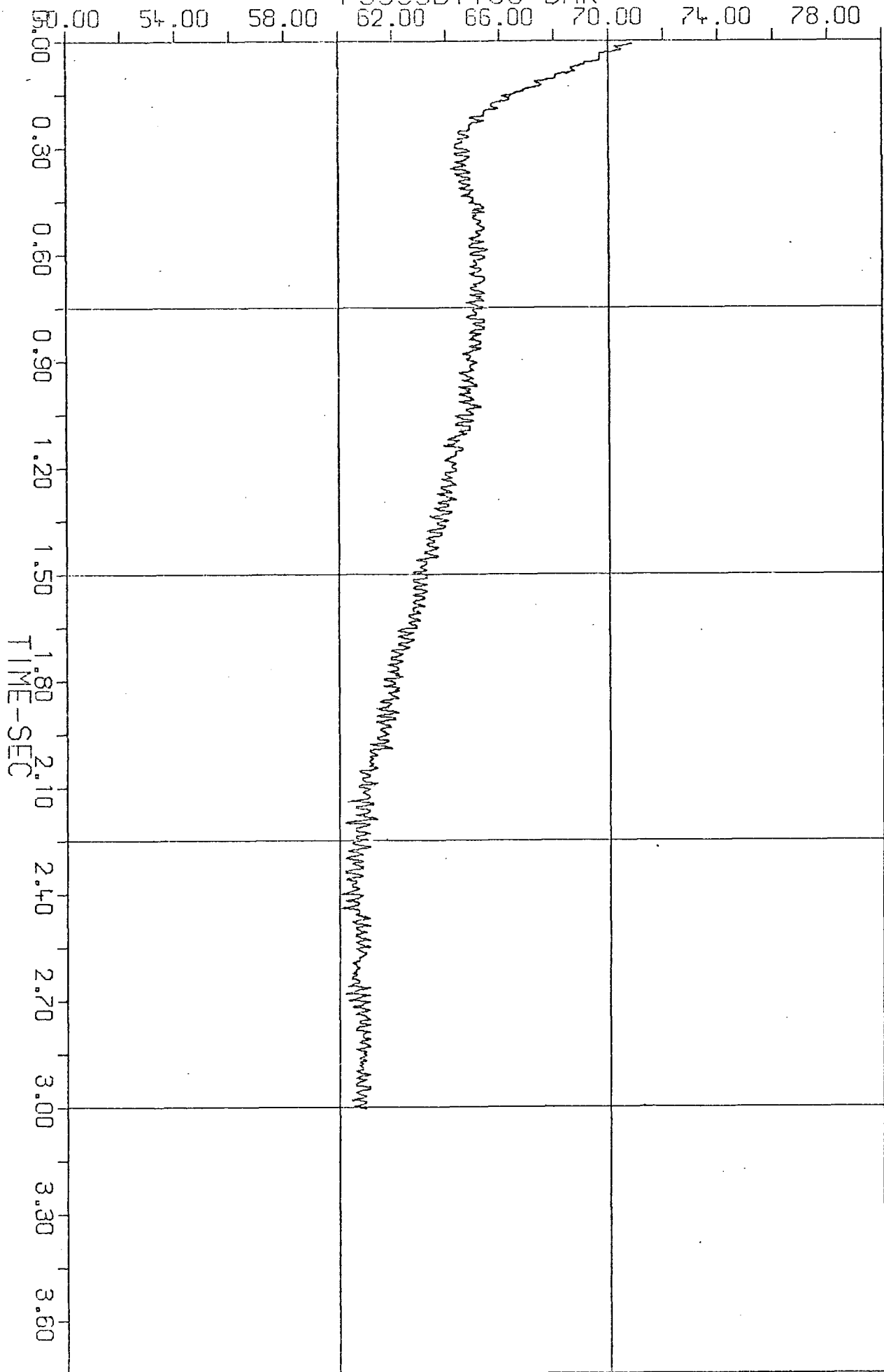

L R A - GARCHING

10-1 * TS999B1180-DEG.C

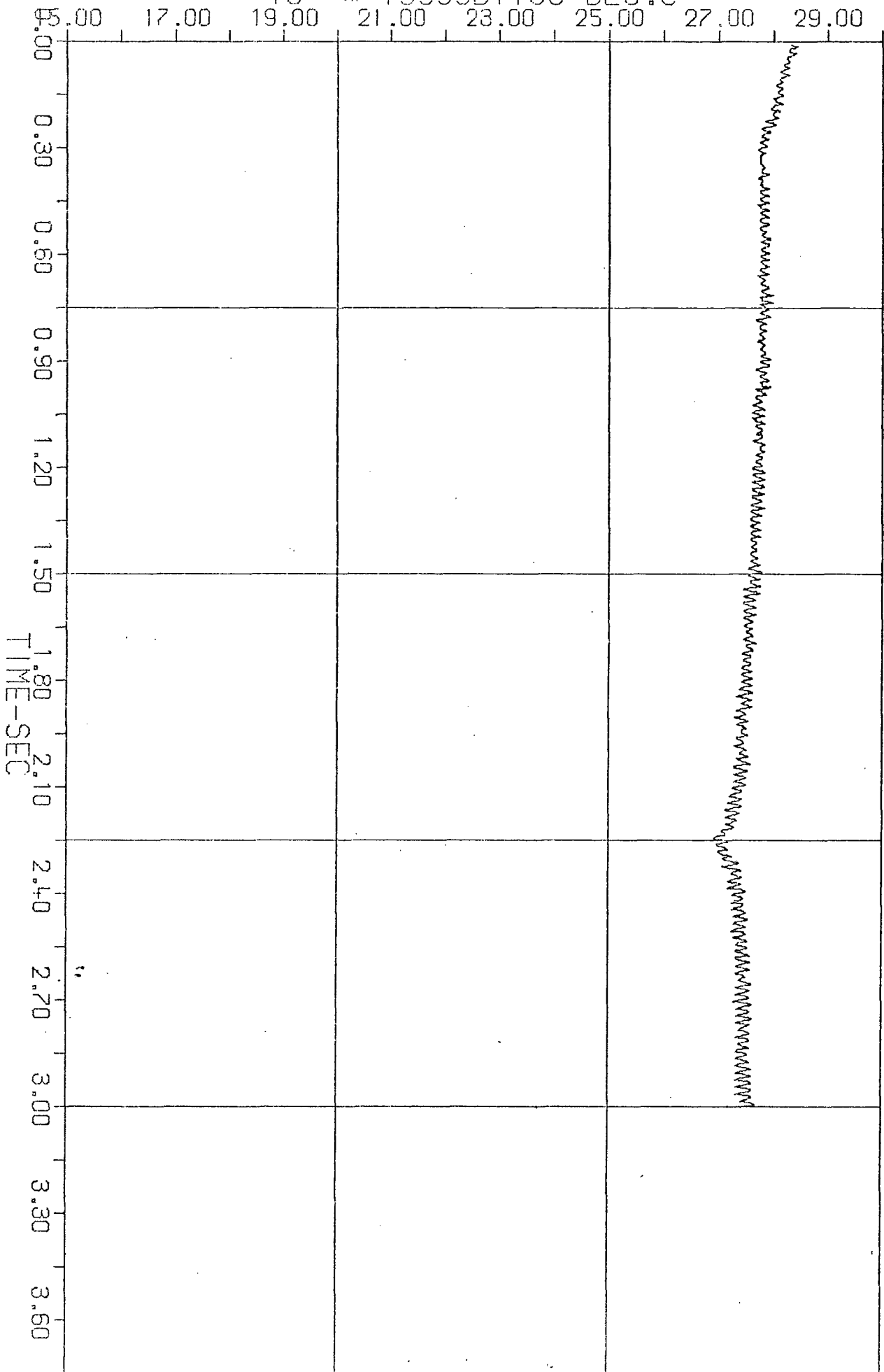

L R A - GARCHING

PS999B5011-BAR

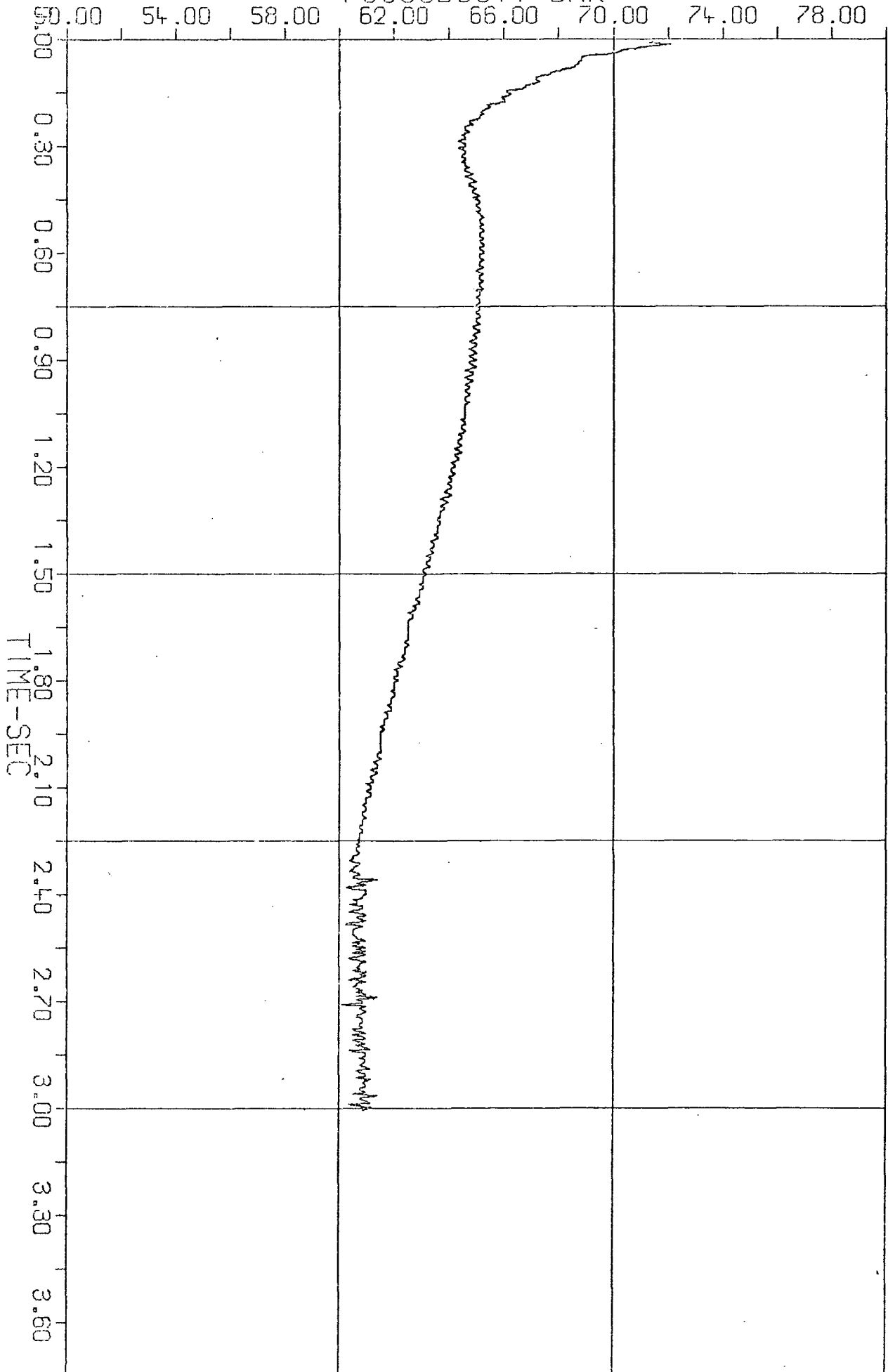

L R A - GARCHING

10-1 * TS999BS009-DEG.C

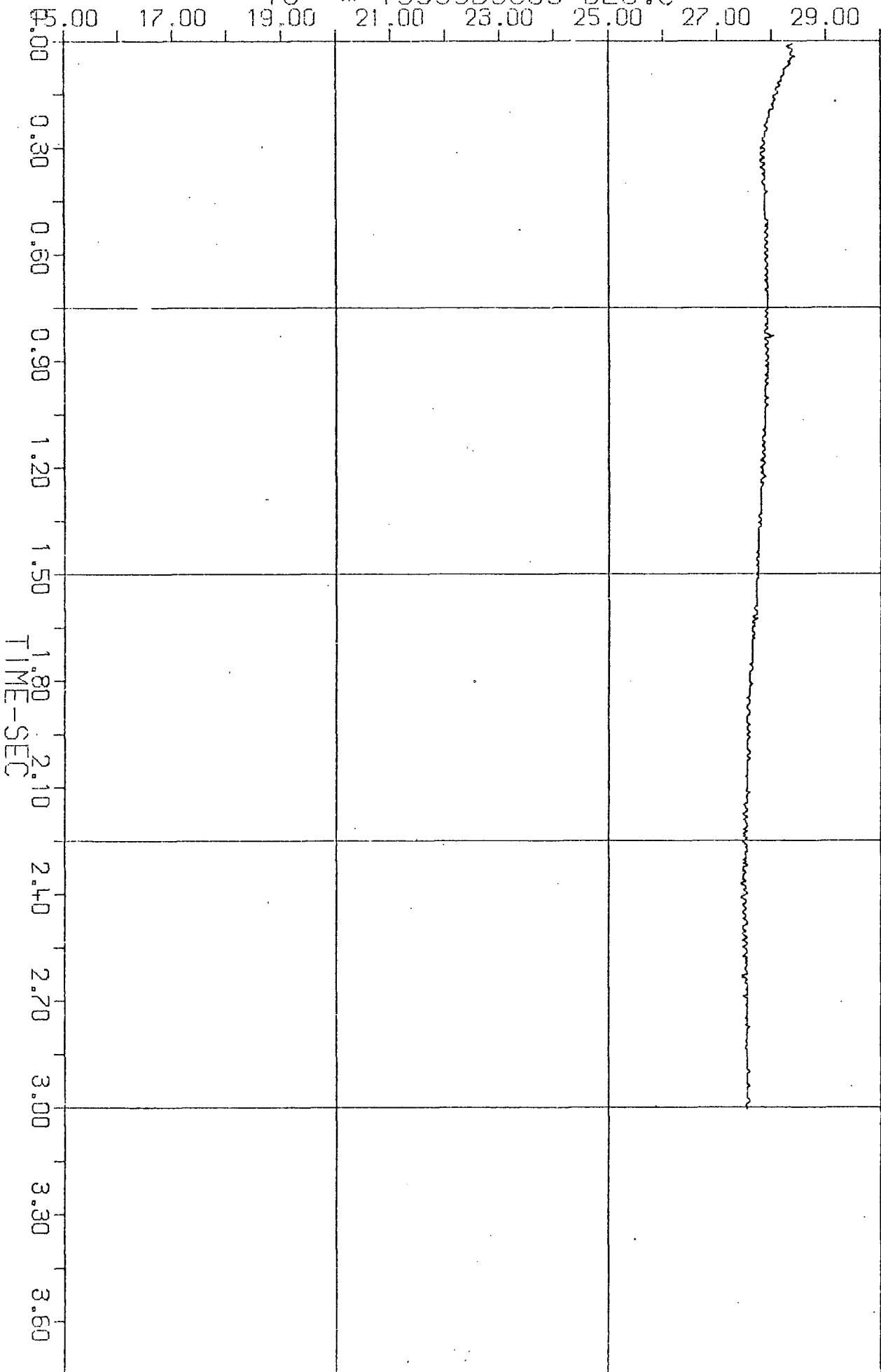

L R A - GARCHING

WATER LEVEL (M)

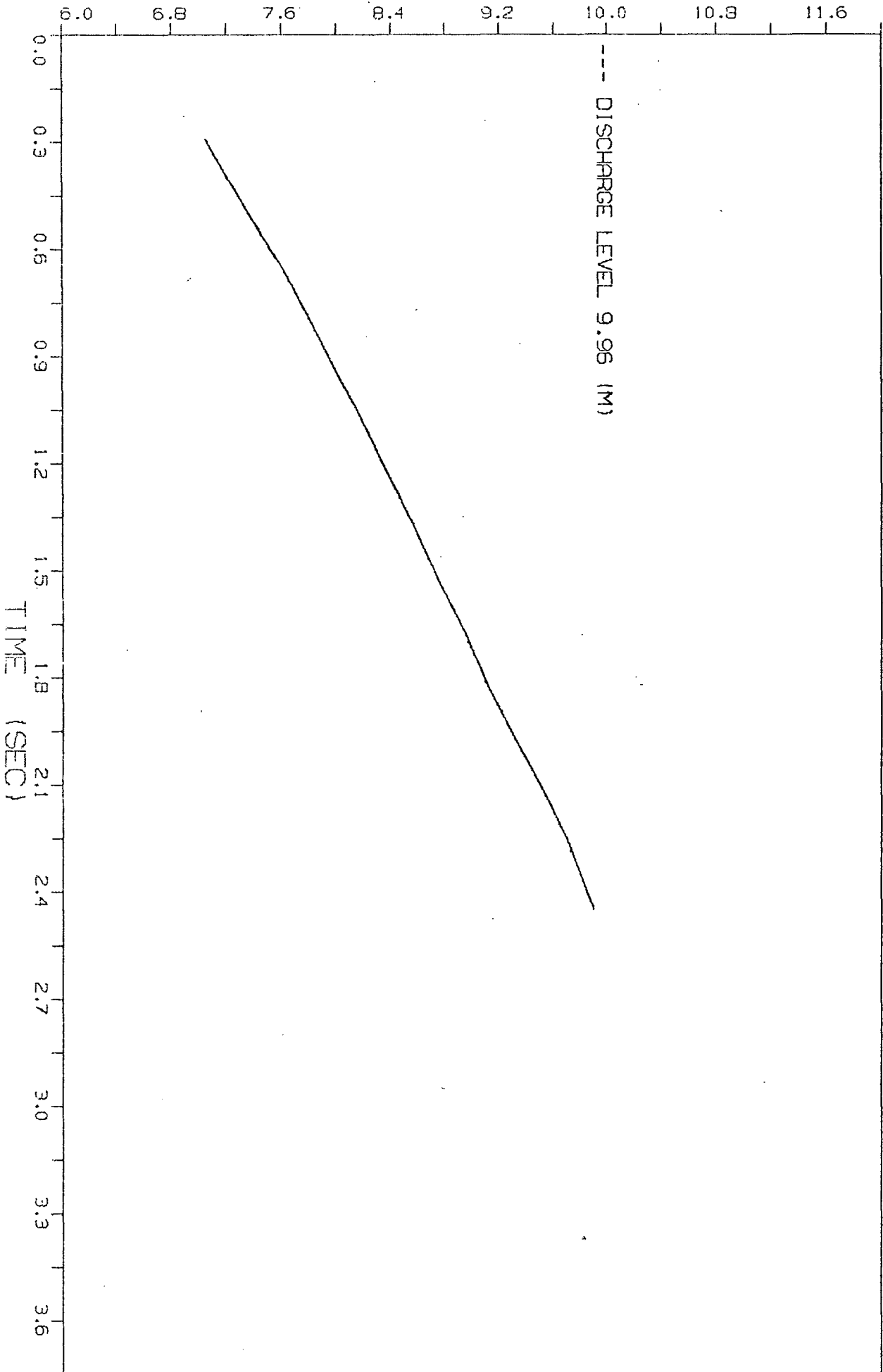

MASS FLOW (KG/S)

0.0 20.0 40.0 60.0 80.0 100.0 120.0 140.0

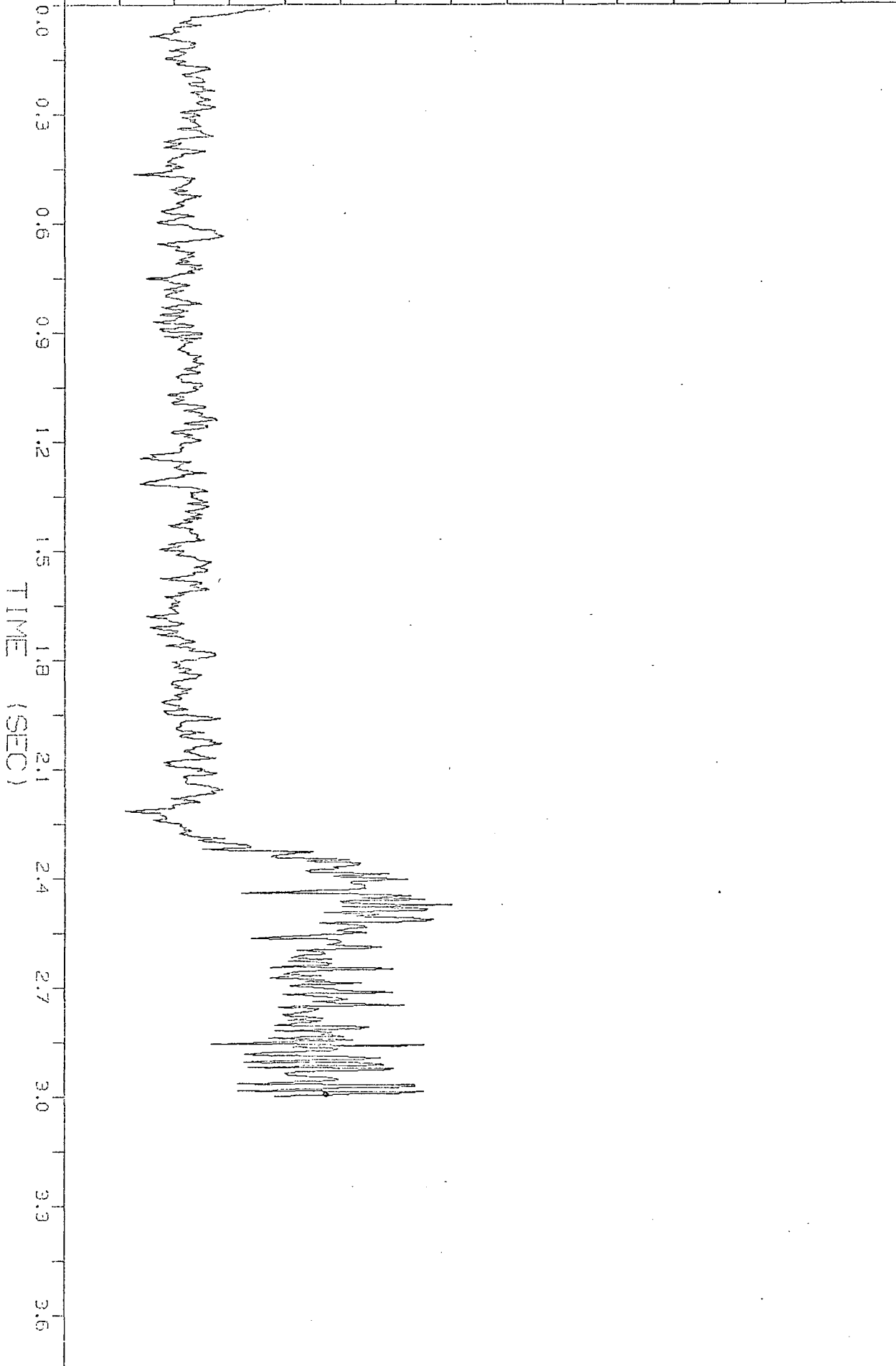

Water level stalk

Meßprinzip:

Die unterschiedliche Leitfähigkeit von Dampf und Wasser wird ausgenutzt, um an diskreten Meßpunkten (Elektroden) O/I-Signale zu gewinnen.

Aus der Höhenlage der Meßpunkte und den Zeitpunkten des ersten Übergangs von Dampf- auf Wasserleitfähigkeit läßt sich der Aufstieg des Wasserspiegels darstellen.

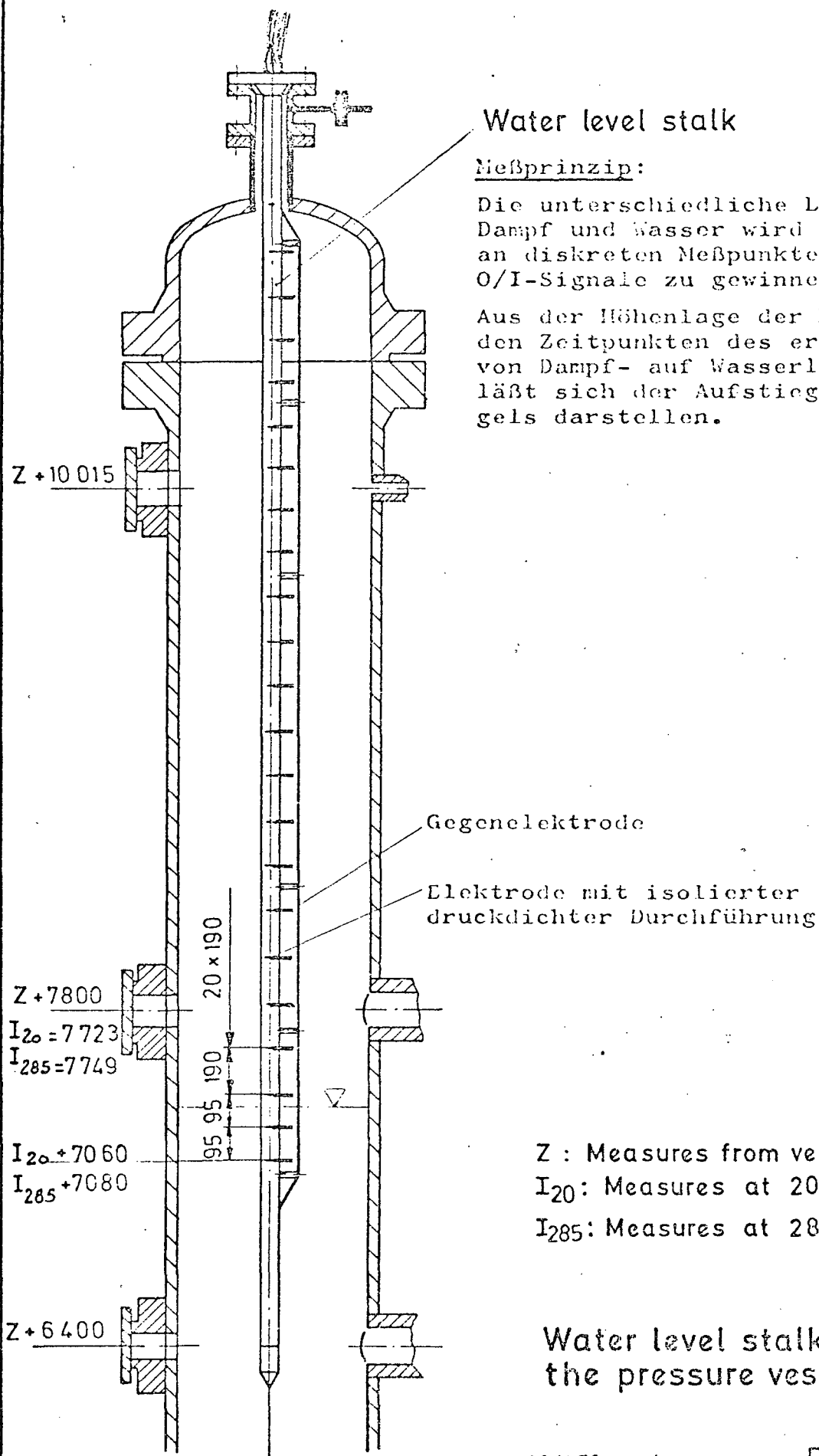

Z : Measures from vessel drawing
 I₂₀ : Measures at 20°C
 I₂₈₅ : Measures at 285°C

Water level stalk in
 the pressure vessel

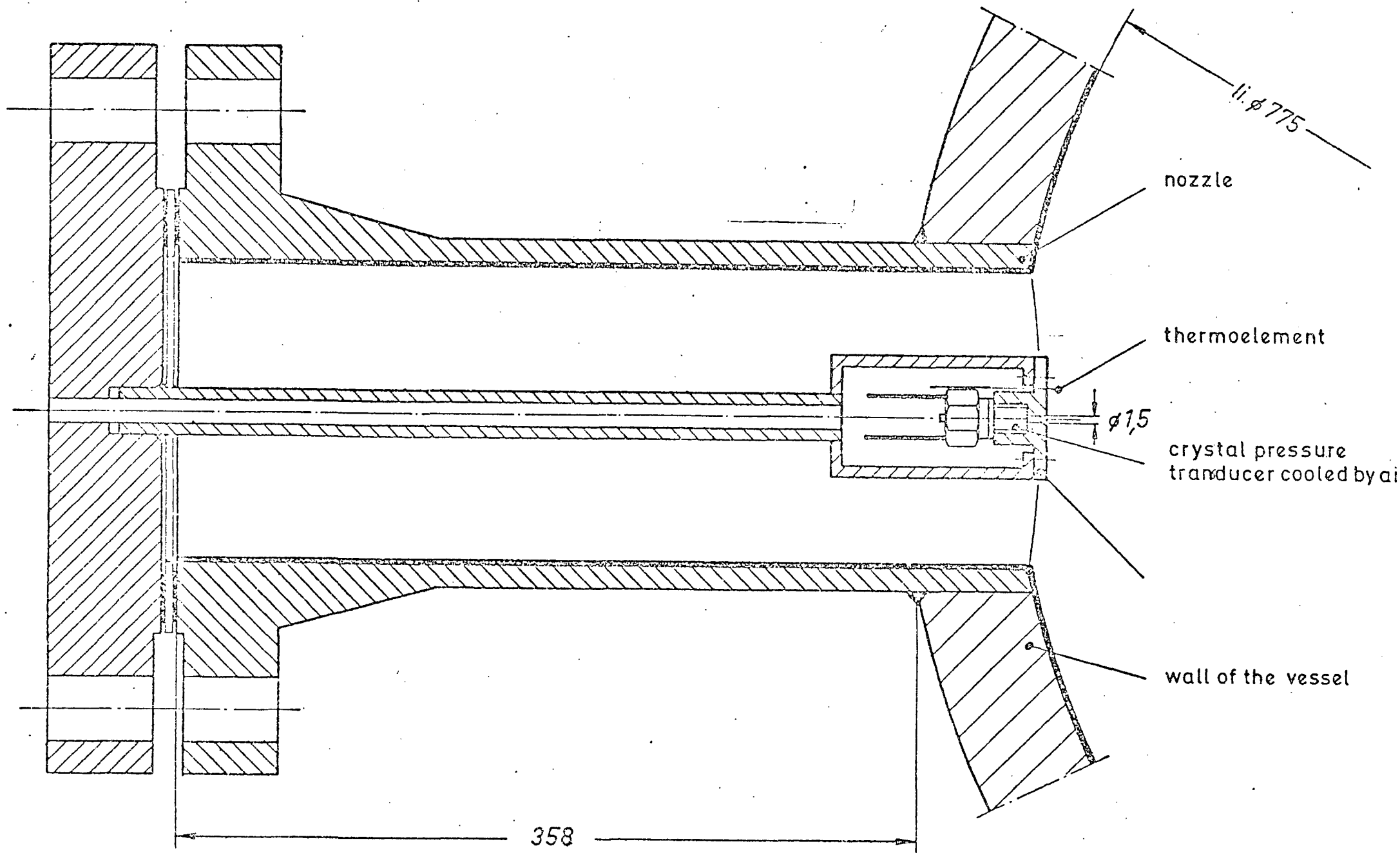

Position of a crystal pressure transducer cooled by air