

**OECD/NEA and IAEA Workshop**

**Experiments and CFD Code Applications to Nuclear Reactor Safety  
XCFD4NRS**

# **Assessment of CFD for NRS**

**B. L. Smith  
Paul Scherrer Institute  
Switzerland**



**Hosted by Commissariat à l'Énergie Atomique (CEA),  
Grenoble, France  
10 - 12 September 2008**

# History

## Initiative

*OECD/NEA -- IAEA Sponsored Meeting:*

Exploratory Meeting of Experts to Define an Action Plan on the Application of Computational Fluid Dynamics (CFD) Codes to Nuclear Reactor Safety Problems

Aix-en-Provence, France, 15-16 May, 2002. Document: NEA/SEN/SIN/AMA(2002)15.

## Action Plan: Set Up 3 Writing Groups under the sponsorship of OECD/NEA

WG1: Chairman J. H. Mahaffy (PSU)

*Provide a set of guidelines for the application of CFD to NRS problems  
(Concluded: December 2006)*

WG2: Chairman B. L. Smith (PSI)

*Evaluate the existing CFD assessment basis, and identify gaps that need to be filled  
(Concluded: December 2007)*

WG3: Chairman D. Bestion (CEA)

*Summarise the extensions needed to CFD codes for two-phase NRS problems  
(To be concluded: December 2008)*

## CSNI Activity Proposal Sheet (CAPS) for WG2

*GAMA(2002)8, Revision 0 (October 2002)*

CSNI: Committee on the Safety of Nuclear Installations
---

## History

### WG2 Expert Group (Original and Subsequent Members)

U. Bieder (CEA), P. Dietrich (IRSN), F. Dubois (IRSN), F. Ducros (CEA), P. Fantoni (Halden), E. Graffard (IRSN), C. Heib (IRSN), M. Henriksson (Vattenfall), T. Höhne (FZR), E. Komen (NRG), F. Moretti (UPisa), J. Mahaffy (PSU), M. Heitsch (GRS), T. Morii (JNES), P. Mühlbauer (NRI), M. Scheuerer (GRS), C.-H. Song (KAERI), T. Watanabe (JAERI), G. Zigh (USNRC)

### NEA Secretariat

J. Royen (2003-2004), Y.-H. Ryu (2004-2006), H.-C. Kim (2006-2007), A. Amri (2008-present)

### Meetings (NEA or OECD Headquarters, Paris)

26-27 Mar. 2003	NEA/SEN/SIN/AMA(2003)13;	9 Sept. 2003	NEA/SEN/SIN/AMA(2003)28
9 March 2004	NEA/SEN/SIN/AMA(2004)9;	29 June 2004	NEA/SEN/SIN/AMA(2004)15
8 Mar. 2005	NEA/SEN/SIN/AMA(2005)10;	13 Sept. 2005	NEA/SEN/SIN/AMA(2005)20
7 Mar. 2006	NEA/SEN/SIN/AMA(2006)10;	8 Sept. 2006	NEA/SEN/SIN/AMA(2006)15
10 May 2007	NEA/SEN/SIN/AMA(2007)7		

### Final Document

Assessment of CFD Codes for Nuclear Reactor Safety Problems    NEA/CSNI/R(2007)13 (180 pages)

## Main Tasks of WG2

- To review critically those NRS problems for which the use of CFD is needed for the analysis, or where its utilisation is expected to result in major benefits
- To review critically the existing assessment basis for CFD application to NRS
- To identify the gaps in the technology and assessment bases
- To propose a methodology for establishing new assessment bases

At the end of 2005, the group produced an interim report, which was submitted to the CSNI via the WGAMA committee...

Assessment of CFD Codes for Nuclear Reactor Safety Problems  
NEA/SEN/SIN/AMA(2005)3

This document contained further proposals...

WGAMA:  
Working Group on the Analysis and  
Management of Accidents

## Proposals

- Form a working group to extend and consolidate the existing WG2 document, to act as a platform for a web-based NRS assessment database, regulated by an NEA webmaster
- As an ongoing action, look for suitable experiments that could form the basis of benchmarking exercises specifically tailored to NRS needs
- Keep in touch with future programmes which could yield suitable benchmarking material; a working group would be formed to become the organisational unit for this exercise
- Organise an International Workshop, with OECD/NEA and IAEA sponsorship, to promote the availability and distribution of experimental data suitable for NRS benchmarking

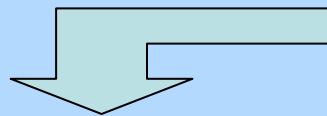

Official Proceedings:  
NEA/CSNI/R(2007)3

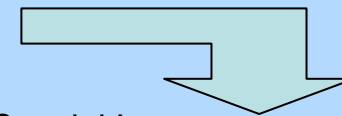

Special Issue:  
Nuclear Engineering and Design  
**238**(3), 443-786 (March 2008)

## NRS problems for which CFD analysis brings real benefits (1)

	<b>NRS problem</b>	<b>System classification</b>	<b>Incident classification</b>	<b>Single- or multi-phase</b>
1	Erosion, corrosion and deposition	Core, primary and secondary circuits	Operational	Single/Multi
2	Core instability in BWRs	Core	Operational	Multi
3	Transition boiling in BWR/determination of MCPR	Core	Operational	Multi
4	Recriticality in BWRs	Core	BDBA	Multi
5	Reflooding	Core	DBA	Multi
6	Lower plenum debris coolability/melt distribution	Core	BDBA	Multi
7	Boron dilution	Primary circuit	DBA	Single
8	Mixing: stratification/hot-leg heterogeneities	Primary circuit	Operational	Single/Multi
9	Heterogeneous flow distribution (e.g. in SG inlet plenum causing vibrations, HDR expts., etc.)	Primary circuit	Operational	Single
10	BWR/ABWR lower plenum flow	Primary circuit	Operational	Single/Multi
11	Waterhammer condensation	Primary circuit	Operational	Multi

## NRS problems for which CFD analysis brings real benefits (2)

	<b>NRS problem</b>	<b>System classification</b>	<b>Incident classification</b>	<b>Single- or multi-phase</b>
12	PTS (pressurised thermal shock)	Primary circuit	DBA	Single/Multi
13	Pipe break – in-vessel mechanical load	Primary circuit	DBA	Multi
14	Induced break	Primary circuit	DBA	Single
15	Thermal fatigue (e.g. T-junction)	Primary circuit	Operational	Single
16	Hydrogen distribution	Containment	BDBA	Single/Multi
17	Chemical reactions/combustion/detonation	Containment	BDBA	Single/Multi
18	Aerosol deposition/atmospheric transport (source term)	Containment	BDBA	Multi
19	Direct-contact condensation	Containment/ Primary circuit	DBA	Multi
20	Bubble dynamics in suppression pools	Containment	DBA	Multi
21	Behaviour of gas/liquid surfaces	Containment/ Primary circuit	Operational	Multi
22	Special considerations for advanced (including Gas-Cooled) reactors	Containment/ Primary circuit	DBA/BDBA	Single/Multi

# 1. Erosion, Corrosion and Deposition

## What is the issue and what is the relevance to NRS?

Corrosion of material surfaces may have an adverse effect on heat transfer, and oxide deposits may accrue in sensitive areas.

Erosion of structural surfaces can lead to degradation in the material strength of the structures. In the primary circuit, corrosion phenomena are encountered on fuel claddings. An oxide layer resulting from corrosion, if thin enough, can protect the surface from further degradation, but if eroded can lead to substantial changes in structural integrity.



## Why is CFD Needed?

The prediction of the occurrence of such phenomena requires simulation at very small scales. The erosion rate depends primarily on water chemistry (pH level, fluid oxygen content) and material properties, but is also influenced by local fluid velocity, temperature, steam quality. These local parameters are flow-regime-dependent, and can only be predicted with a proper CFD tool.

## Example of what has been done

Ferng et al. (2006) have predicted the wall thinning locations on the shell wall of feed water heaters using CFX 4.2 with an impingement erosion model implemented into an Eulerian/Lagrangian model of the flow of steam and water droplets. The predicted wear sites on the shell wall corresponded well with measured data obtained from a PWR located in the southern region of Taiwan.

Ferng Y. M., Hsieh J. H., Horng C. D. Nuclear Technology, **153**, 197-207 (2006).

# Verification and Validation

**Verification** is the process that confirms that accurate and reliable results can be obtained from the models programmed into the code. Verification process entails comparing code predictions against exact analytical results, manufactured solutions, or previously verified higher accuracy simulations.

**Validation** is the process of determining whether these basic models represent physical reality. Can only be accomplished by comparing numerical predictions against measured data.

P. Roache (1988)...

Verification — solving the equations right

Validation — solving the right equations

Let's add two more definitions...

Application — performing the intended task

Demonstration — proving capability

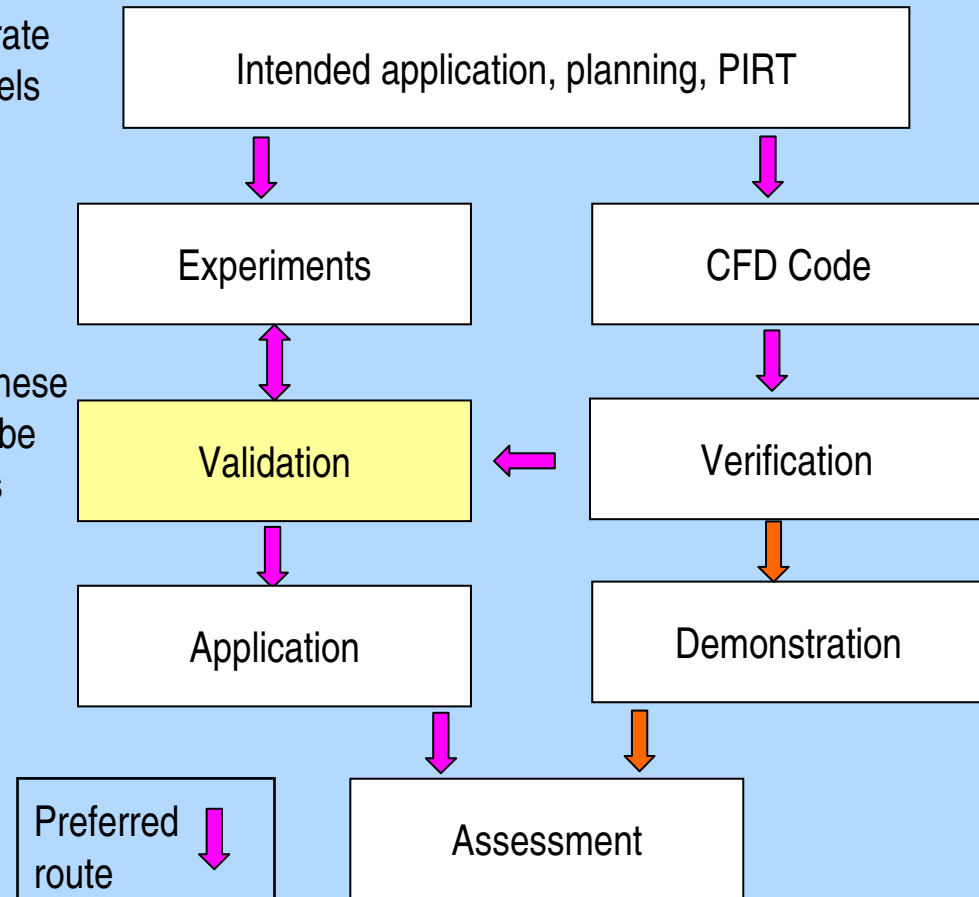

Ideally, a separate assessment matrix should be prepared for every application. This is a very demanding task.

Fortunately, many of the phenomena are common to other situations, and may be validated against existing data.

## Validation Tests Performed by Major CFD Code Vendors (Example 1)

Whereas verification should be performed mainly by code developers, validation and demonstration are strictly application-dependent and must therefore be performed, or at least overseen, by users.

Nonetheless, basic validation procedures of a generic type have been undertaken by all the major code vendors. The information has been taken from established databases concerned with basic flow phenomena.

### Backward-Facing Step

Examines several important aspects of turbulent flows: separation of a turbulent boundary layer, reattachment of the boundary layer, recirculation.

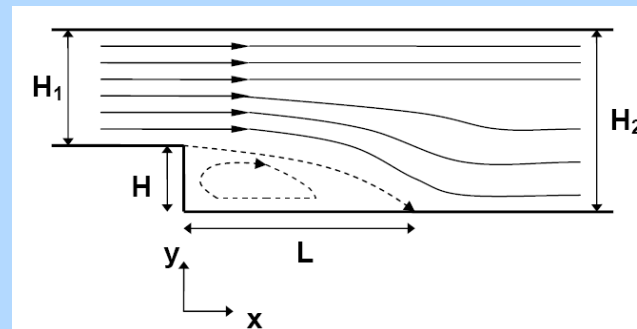

There is a wealth of experimental data for increasing  $Re$ . Simulations include DNS, LES and different RANS models. Care is taken that upstream conditions are fully developed and the velocity profile measured.

Velocity profiles downstream of the step are also measured, capturing the recirculation region and beyond.

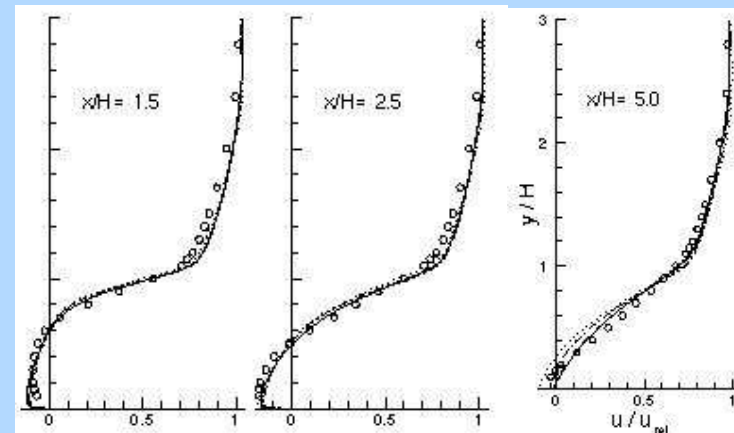

## Validation Tests Performed by Major CFD Code Vendors (Example 2)

### Impinging Jet

Examines several important aspects: jet spreading, entrainment from surroundings, successive deceleration, acceleration and again deceleration in Regions 1, 2 and 3, respectively. Finally, there is the boundary layer growth over the plate.

Normal case for axisymmetric jet normal to impact plane for different  $H$  to  $D$  ratios, but experiments exist for oblique incidence too.

Typical data for comparison:

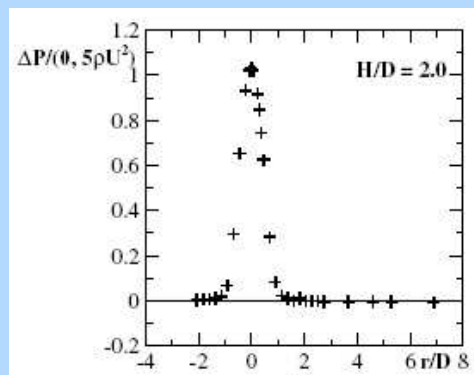
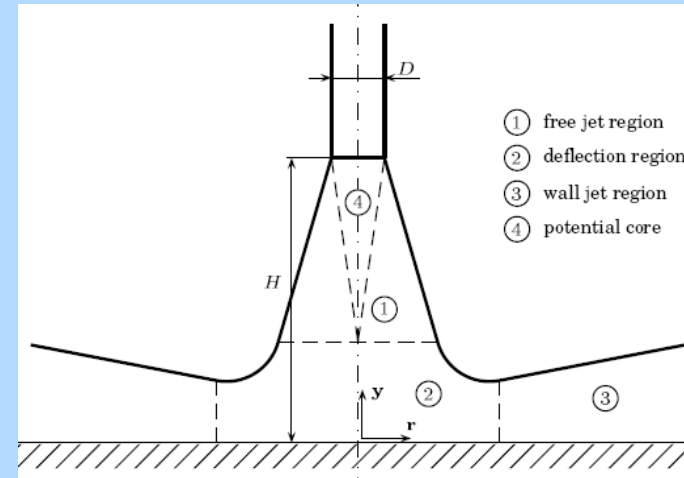

Pressure on the plate

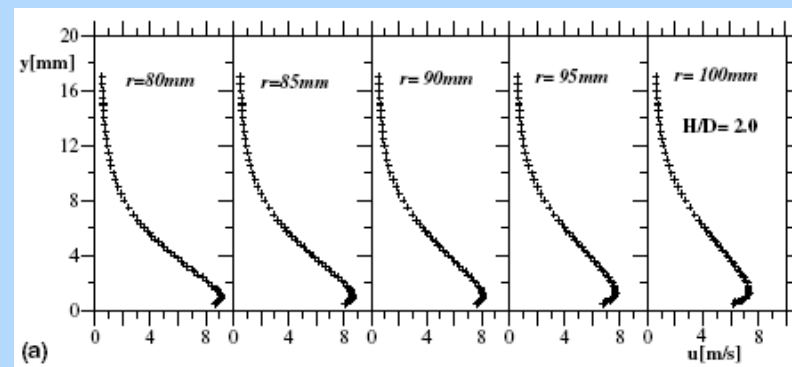

Velocity profiles at different radii

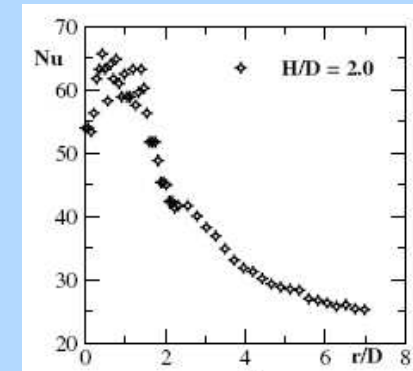

Nusselt number  
(heated plate)

## Existing Databases (Non-Nuclear)

**ERCOFTAC** (European Research Community on Flow, Turbulence and Combustion)

The database was started in 1995, and is actively maintained by the University of Manchester, UK. It contains experimental as well as high-quality numerical data relative to both academic and applied CFD applications.

ERCOFTAC hold regular [Workshops on Refined Turbulence Modelling](#) around Europe, information from which is used to update and refine the database.

The [Classic Data Base](#) is open to the public (but registration is needed when downloading data). There are more than 80 documented cases, either containing experimental data, or with DNS/LES data available. Each case contains at least a brief description, some data to download, and references to published work. Some cases contain significantly more information than this. Some of the cases could be used also in NRS applications, such as flow in curved channels, mixing layers, and flows through tube bundles.

Cases have been categorised by flow type, for convenience:

**Free Turbulent Flows:** homogeneous flows; free shear flows; interacting shear flows

**Flows Around Bodies:** two-dimensional flows; three-dimensional flows

**Semi-Confined Flows:** 2D boundary layers; 3D boundary layers; wall jets;  
flows around bodies interacting with boundaries; free-surface flows

**Confined Flows:** flows without separation; flows with separation; cavity flows; unsteady flows

When simulating a new NRS case, “test” yourself in advance on an associated classic flow from this database.

<http://cfd.mace.manchester.ac.uk/ercoftac/>

## Existing Databases (Non-Nuclear)

### QNET-CFD

A Thematic Network for Quality and Trust in the Industrial Application of Computational Fluid Dynamics. partly funded by the EU, four years were spent in assembling and collating knowledge and know-how across a range of CFD applications.

The knowledge base is hierarchically structured around the notions of Application Areas. These are: External Aerodynamics; Combustion and Heat Transfer; Chemical and Process, Thermal Hydraulics and Nuclear Safety; Civil Construction and HVAC (heating, ventilation and air conditioning); Environmental Flow; Turbomachinery Internal Flow.

Specific NRS items under Chemical and Process, Thermal Hydraulics and Nuclear Safety are:

buoyancy-opposed wall jet; induced flow in a T-junction;; buoyant gas air-mixing; mixed convection in a reactor (containment gas mixing); spray evaporation in turbulent flow; combining/dividing flow in a Y junction; downward flow in a heated annulus.

For each Application Challenge, its description, test data, CFD simulations, evaluation, best practice advice, and related underlying flow regimes should all be available. Again, it is necessary to register before downloading data.

Good material here for user training in appropriate application area.

<http://eddie.mech.surrey.ac.uk/>

## Existing Databases (Non-Nuclear)

### NPARC Alliance Data Base

Chiefly orientated towards the aerodynamics community, CFD Verification & Validation provides a tutorial as well as available measurements and data for CFD cases. Link to the data archive of NASA also useful. High-quality data available in the following areas:

incompressible, turbulent flow over a flat plate; RAE 2822 transonic airfoil; S-Duct; subsonic conical diffuser; 2D diffuser; supersonic axisymmetric jet flow; incompressible backward-facing step; ejector nozzle; transonic diffuser; hydrogen-air combustion in a channel; two-stream mixing; laminar flow over a circular cylinder.

<http://web.arnold.af.mil/nparc/>

### AIAA (American Institute of Aeronautics and Astronautics)

The society participates to the definition of standards for CFD in its “Verification and Validation Guide”, and has important links to web sites containing lists of references (papers, books, author coordinates) related to CFD verification and validation. Also, various links with other web sites gathering information of aeronautical interest. Some of these links may be useful for CFD validation, but would need sifting for relevance to tNRS.

<http://www.aiaa.org/>

### Vattenfall Data Base

Detailed turbulence statistics up to fourth order are available for all three velocity components for a wall jet. The turbulence structure in the near-wall region is qualitatively very similar a flat plate boundary layer, but higher in magnitude.

[Eriksson J; Karlsson R; Persson, J Exp. Fluids, 25, 50-60 \(1998\).](#)

## EU Framework Programmes

Some EU FWP are listed below as sources of information on and links to assessment databases.

### **ASTAR** (Advanced Three-Dimensional Two-Phase Flow Simulation Tool)

A 5th EU FWP (shared-cost action) dedicated to the further development of high-resolution numerical methods, and their application to transient two-phase flow. Several benchmark exercises were adopted as V&V procedures for comparing the different modelling and numerical approaches.

<http://www.grs.de/astar>

### **ECORA** (Evaluation of Computational Fluid Dynamics Software for Reactor Safety Analysis)

A 5th EU FWP to evaluate the capabilities of CFD software packages to simulate flows in the primary system and containment of nuclear reactors. Some of the documents are in the public domain and give information and links to BPGs, verification and validation tests.

<http://domino.grs.de/ecora/ecora.nsf>

### **EUBORA** (EU Concerted Action on Boron Dilution Experiments )

A 4th EU FWP to discuss and evaluate the needs for a common European programme to validate the calculation methods for assessing transport and mixing of diluted and boron-free slugs in the primary circuit during relevant reactor transients, and to discuss how inhomogeneous boron dilution issues should be addressed within the EU.

[Tuomisto, H., et al., "EUBORA: Concerted Action on Boron Dilution Experiments" \(Proc. Conclusive Symposium on EU Fission Safety Research under the 4th Framework Programme - FISA 99\), EUR 19532, Commission of the European Communities, Luxemburg \(1999\).](#)

## EU Framework Programmes

### FLOWMIX-R (Fluid Mixing and Flow Distribution in the Reactor Circuit)

Another 5th EU FWP addressing in-vessel mixing, particularly in respect to the boron dilution issue. Benchmark calculations for selected experiments were used to justify the application of particular turbulent mixing models, to reduce the influence of numerical diffusion, and to decrease grid, time step and user effects in CFD analyses.

<http://www.fzd.de/FWS/FLOMIX/>

### ASCHLIM (Assessment of Computational Fluid Dynamics Codes for Heavy Liquid Metals)

A 5th EU FWP (Accompanying Measure) aimed at improving predictive capabilities of CFD codes to simulate flows associated with the Accelerator Driven System (ADS) concept. Some benchmarking against experimental data was undertaken. Very few measurements of turbulence quantities are available, and uncertainties in specifying the turbulent Prandtl number persist.

Benchmark data provided from several liquid-metal experiments, some of generic interest — for example, flow of mercury around a heated U-bend — and others more prototypic of reactor cores (TEFLU tests at FZK, Germany).

ASCHLIM 2002, Assessment for computational codes in heavy liquid metal flows, EU-Contract number FIKWCT2001-80121.

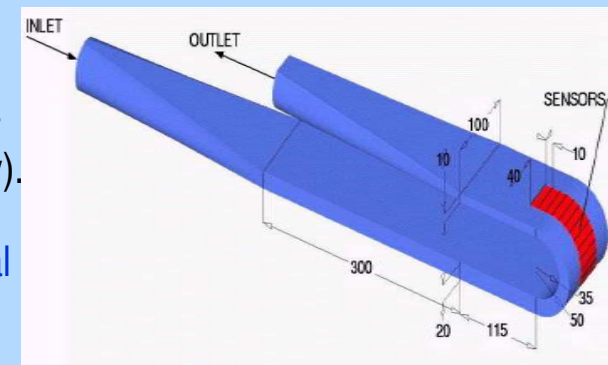

The EU Framework Programmes rarely fund new experiments, but are useful reference points for benchmarking material, which is why they were included in the WG2 document.

## Existing Databases (Nuclear): Boron Dilution

During boron-dilution events, a volume (slug) of boron-deficient water enters the reactor core after start-up of the main circulation pump, or after recovery of natural circulation. Experiments generally try to reproduce the mixing in the reactor downcomer and lower plenum, upstream of the reactor core inlets.

### University of Maryland Tests

Very detailed results are available from a series of tests undertaken at 1/5<sup>th</sup> scale. The data were used to define the OECD/NEA ISP-43.

Detailed boundary conditions were provided for the analysts, and time histories of temperatures at nearly 300 positions at eleven levels within the downcomer and lower plenum were available. The T/C positions are marked in the figure.

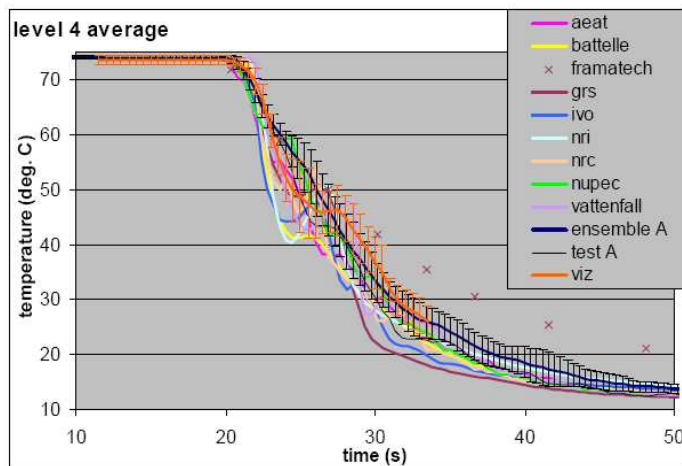

Azimuthally-averaged temperatures at the base of the downcomer are compared against test data (with error bars). The calculations were done 'blind' for the ISP. Post-test analyses would show improvements.

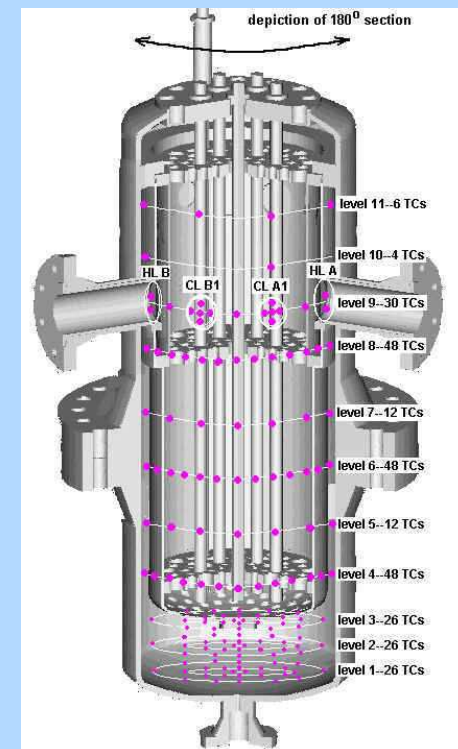
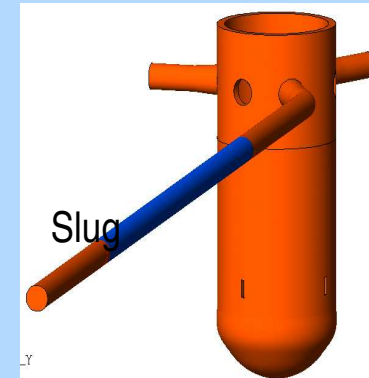

## Existing Databases (Nuclear): Boron Dilution

### ROCOM Tests (FZD Rossendorf)

Constructed in 1998, ROCOM is a 1/5th scale Plexiglas model of the German PWR Konvoi, consisting of four loops. Demineralised water is used, with coolant mixing investigated by the injection of slugs of a tracer solution (diluted salt) into one loop.

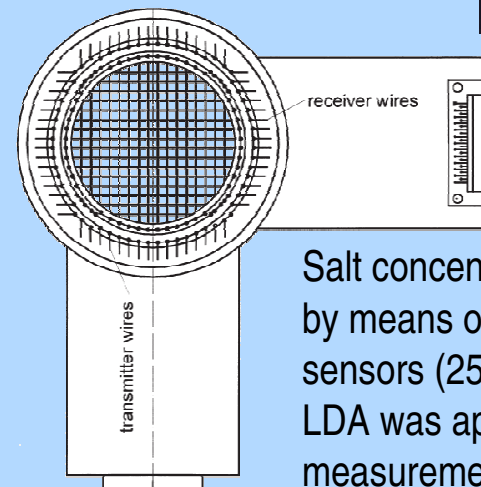
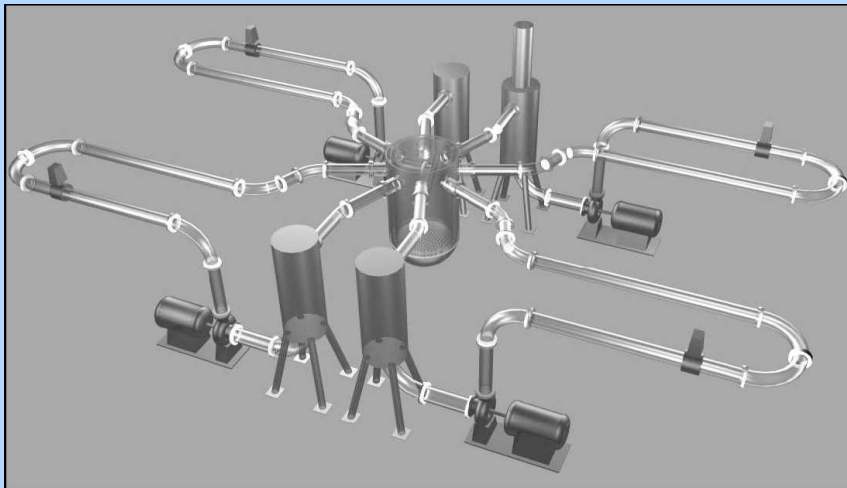

Salt concentration was measured by means of wire mesh conductivity sensors (256 measuring points). LDA was applied for velocity measurements

These were installed in the cold leg inlet nozzle, in the downcomer, before the entrance into the lower plenum, in the lower core support plate (one measuring position at each fuel element position) and in all four outlet nozzles.

The rig can be modified to analyse general mixing phenomena as well as boron dilution studies, and indeed test data were released in the context of the FLOMIX-R 5<sup>th</sup> FWP.

## Existing Databases (Nuclear): Boron Dilution

### OKB GIDROPRESS (Russia)

1/5th scale model of a VVER-1000, a part of one cold leg with loop seal at RCP inlet is reproduced. Boron concentration is reproduced using cold water in the reactor with a hot water slug. Core model has 151 simulators of fuel assemblies having about the same hydraulic resistance as the actual fuel assemblies. Fast-response T/C are installed at the core inlet (80 positions) and in lower part of the downcomer.

Some problems with uncertainty of the measured quantities (loop flow rates) and with wall heat transfer. Improved results obtained once the walls are explicitly modelled, though solution of conjugate heat transfer problems is much more demanding in terms of computer memory and CPU time. This is a common problem of all experiments where temperatures are measured.

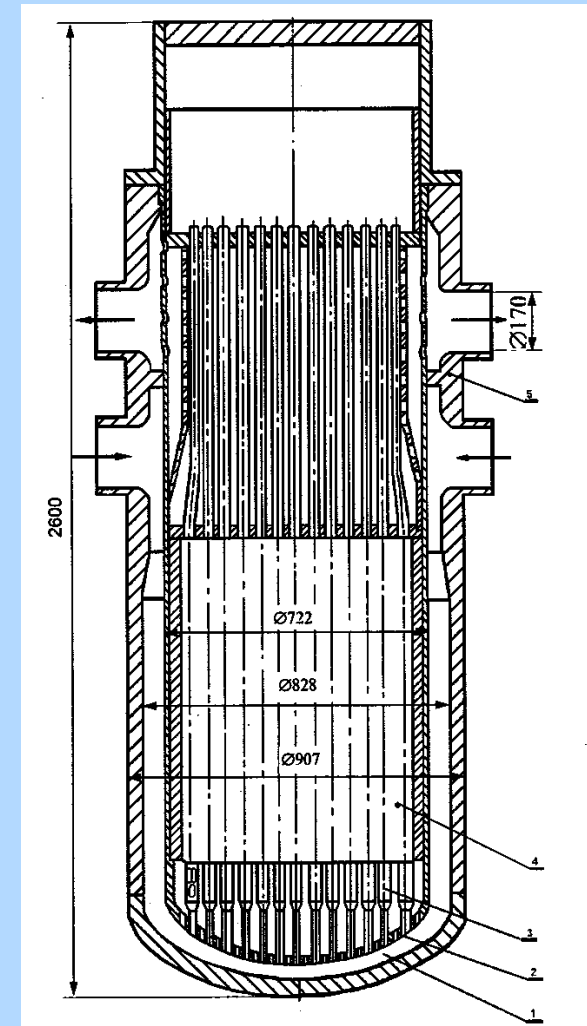

Test data from 3 experiments were released for CFD simulation in context of the FLOMIX-R 5<sup>th</sup> FWP.

## Existing Databases (Nuclear): Boron Dilution

### Vattenfall Tests (Sweden)

The experiment is a 1/5th-scale model of a 3-loop PWR pressure vessel. Borated water is represented by tap water, and the deborated slug by a salt-water solution with a suitable amount of an organic fluid of low density added to bring the average mixture density so close to that of the tap water that buoyancy forces were negligible.

Measurements of concentrations at the “core” inlet and velocities in the downcomer for four transient cases, VATT-01 (large slug), VATT-02 (medium-sized slug), VATT-03 (small slug) and VATT-04 (slow transient), were released within the FLOMIX-R project. Both steady-state (only velocity field calculated) and transient simulations were simulated within the project

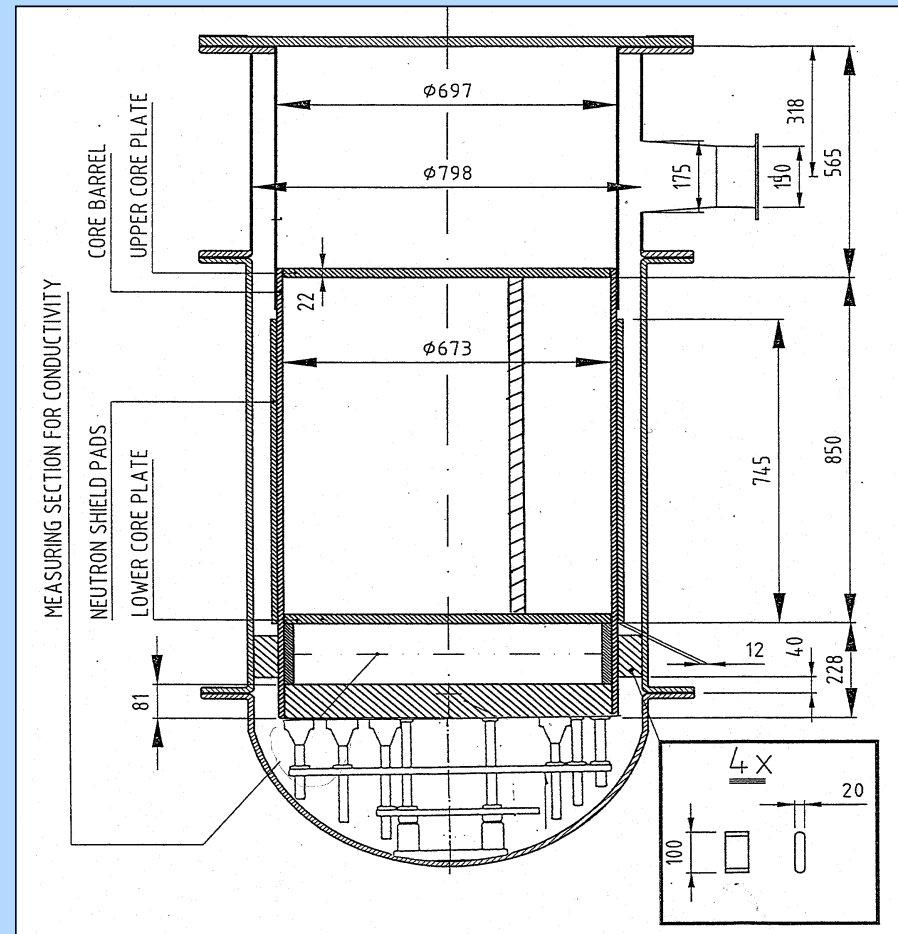

## Existing Databases (Nuclear): Pressurised Thermal Shock (PTS)

Most attention has been paid to the two-phase PTS issue, with high pressure injection from the top into a partially filled cold-leg pipe.

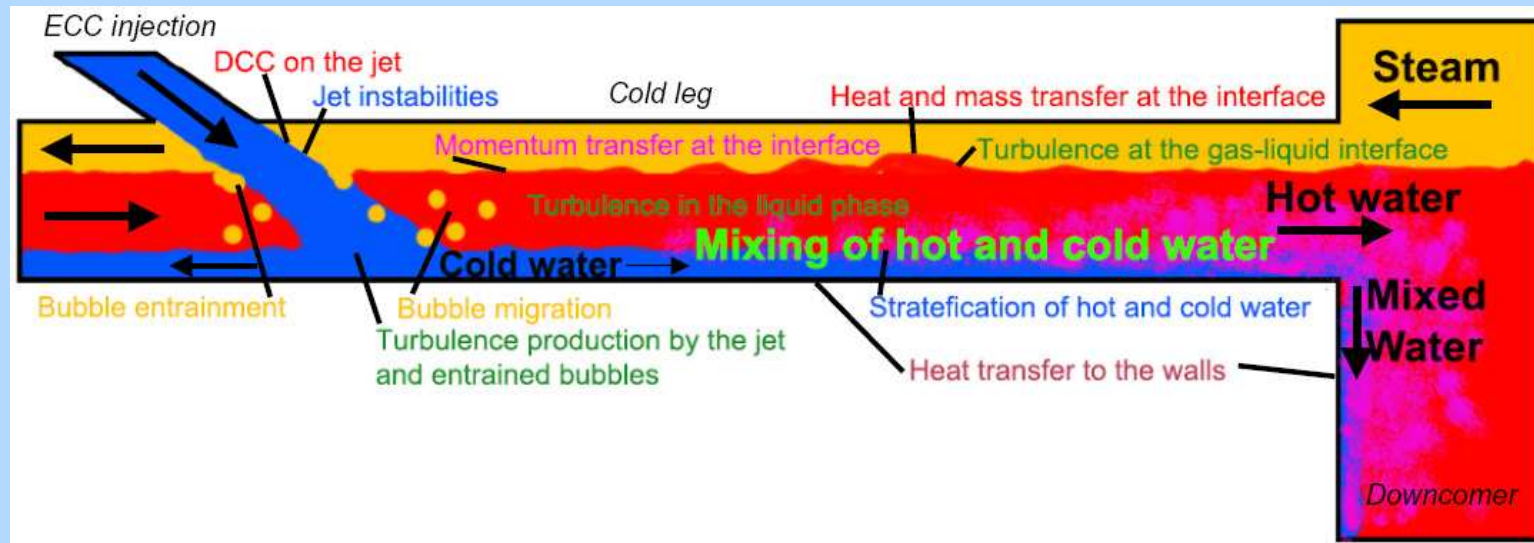

Experimental data available:

- IVO (FORTUM) test facility (Finland)
- UPTF Facility (Germany)
- ROCOM Facility (Germany)
- APEX Test Facility (USA)

Aspects of the PTS scenario were investigated in the ECORA 5<sup>th</sup> FWP, and more comprehensively in the NURESIM 6<sup>th</sup> FWP

## Existing Databases (Nuclear): Pressurised Thermal Shock (PTS)

### TOPFLOW-PTS Experiments (FZD, Rossendorf)

This is a unique facility, presently being commissioned. The test section (scale 1/2.5) is located inside a pressure vessel of length 7m and 2.5m inner diameter. Experiments can be carried out at up to 50 bar pressure, but parts of the test section can be constructed of glass due to pressure equalisation, enabling full visualisation access. It is highly instrumented with thermocouples, heat-flux probes, wire-mesh sensors, local void probes, high-speed camera observation, infrared camera observations and local conductivity probes.

The geometry is based on the French CPY 900 MWe reference plant.

It is planned to operate the test mock-up in steady-state conditions with and without mass transfer due to condensation, as well as in transient operational mode.

Access to the data from the tests will be restricted to the partners in the consortium who have financed them.

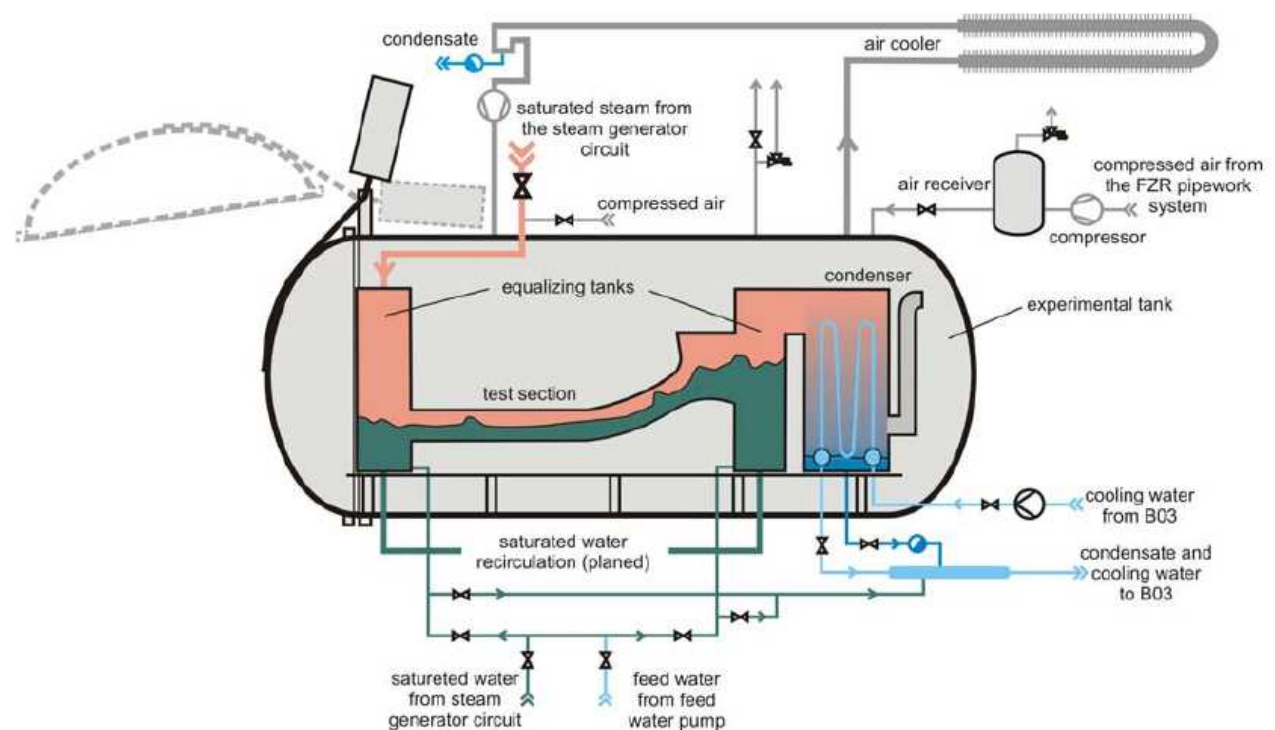

## Existing Databases (Nuclear): Thermal Fatigue – What is the Issue?

Failures of parts of structures of NPPs caused by thermal fatigue include Genkai Unit 1 (Japan), Tihange Unit 1 (Belgium), Farley Unit 2 (USA), PFR (UK), Tsuruga Unit 2 (Japan) and Loviisa (Finland). Consequently, considerable effort has been devoted to research of this phenomenon.

First studies in the 1980s in LMFBRs: fatigue phenomena were observed in the secondary loop of the Phénix prototype reactor as well as in a Tee-junction of Superphénix. The IAHR (International Association for Hydraulic Engineering and Research) defined a benchmark activity around the issue.

A resurgence of interest in Tee-junctions arose due to a failure event at the Civaux-1 PWR (1450 MWe N4) in May 1998. This led to the replacement of RHR circuit on all four N4 units in France by the earlier 1300 MWe design.

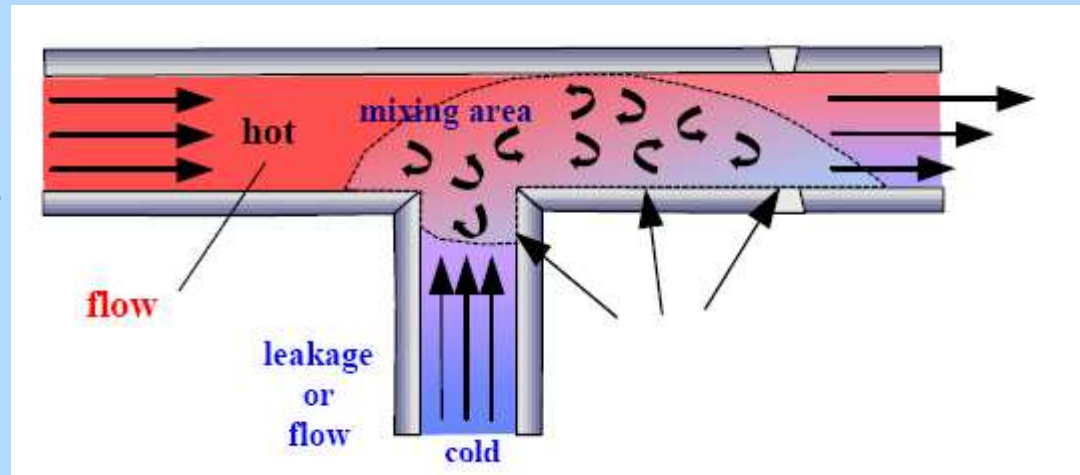

Critical parameters: frequencies ( $\omega$ ); temperature differences ( $\Delta T$ ); number of cycles ( $N$ ); material properties  
 Most damaging thermal loads appear to be due to large-scale turbulent fluctuations; i.e. identification and quantification of non-steady phenomena of low frequency (3-10 Hz) are important

## Existing Databases (Nuclear): Thermal Fatigue

### Vattenfall Benchmark

Very careful tests performed at Älkarleby Laboratory in Sweden: invitation to submit 'blind' calculation, and then organisers will provide measured data. This benchmark is open to all who wish to participate.

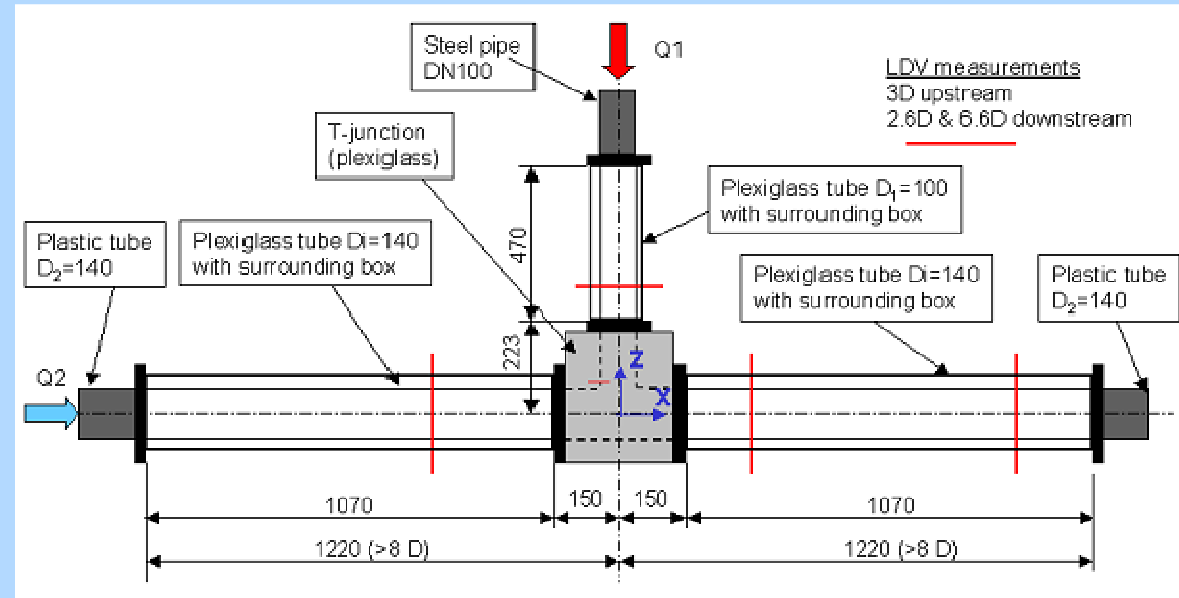
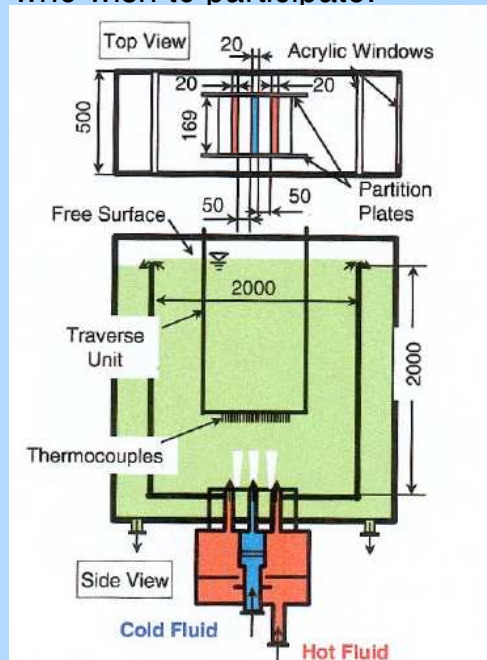

### Parallel Striping Fatigue

High-cycle fatigue problem caused by two or more parallel jets at different temperatures in contact with neighbouring structures, such as at core outlet of LMFBR. Figure left shows test section at O-arai Engineering Center in Japan.

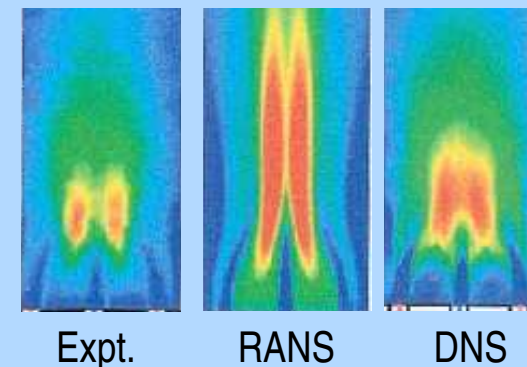

Turbulence modelling is vital in thermal fatigue

## Gaps in the Assessment Databases (1)

### Aerosol Transport in Containments

Possible experimental database could include OECD/NEA activities in the field of aerosol behaviour: ISP-37 (VANAM M3 Aerosol Behavior in the Battelle Model Containment), the AHMED Code Comparison Exercise, ISP-44 (KAEVER test facility, VTT, Finland).

However, the most cited reference remains the Phebus FP Severe Accident Experimental Program at CEA Cadarache, which reproduces (at scale) a core meltdown accident in a 900 MW PWR. Aerosols were released into a mock-up containment. Though CFD codes were used within the PHEBEN2 EU-supported project based on the PHEBUS FPT0 and FPT1 experiments, no local measurements of aerosol deposition are available.

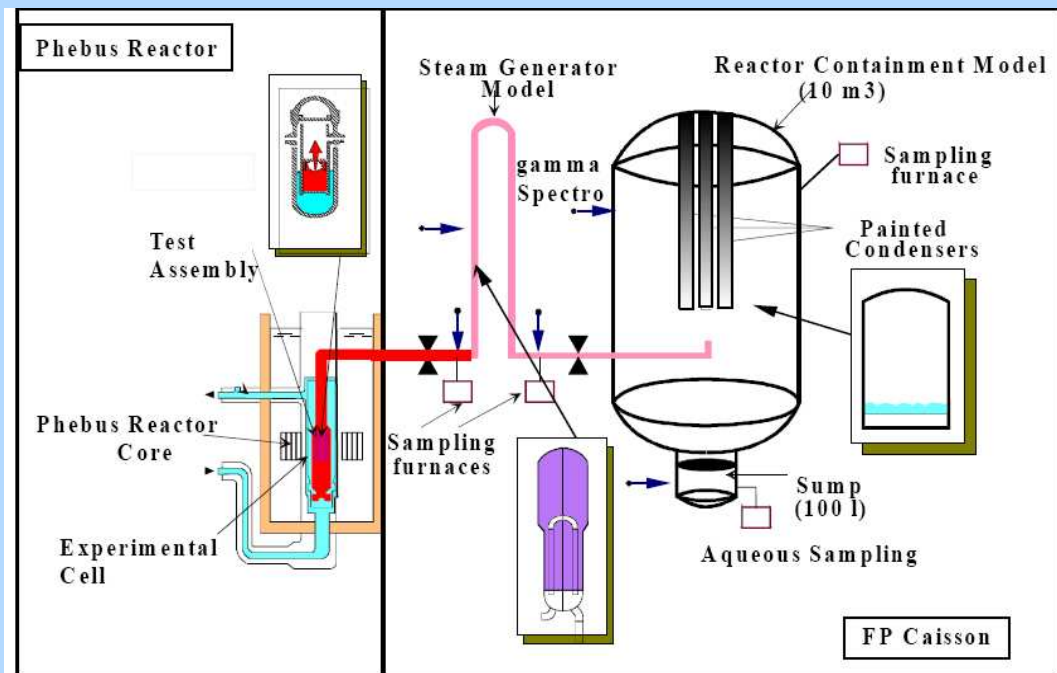

In a recent PIRT (see later), aerosol deposition in containments was ranked ahead of thermal fatigue in priority, but there are no data from the nuclear area useful for CFD validation

## Gaps in the Assessment Bases (2)

### Isolating the CFD Problem

Traditional 1-D system codes need to be “manipulated” to take account of 3-D effects, when this aspect needs to be taken into account during a safety analysis. A local 3-D CFD computation is required in such cases to produce more trustworthy results. However, there is the difficulty of specifying the initial conditions (e.g for the velocity field and temperature distribution) for a “stand-alone” CFD simulation being performed during a transient. Often too, there is a strong feed-back from the system parameters. The best way forward is to couple a CFD code with a system code (see later).

### Stratification and Buoyancy Effects

Stratified flows and buoyancy-induced effects (due to density differences) take place in many parts of the flow circuit: main vessel, lower and upper plena, pipes, and hot and cold legs. There are also important stratification issues in containment modelling and for passive decay-heat removal. Mostly, the phenomena are associated with unsteady 3D flow situations. The issue is to derive a modelling strategy able to handle all the situations of relevance to NRS.

For single-phase flows, the main uncertainties arise in connection with the turbulence modelling. The standard two-equation RANS models ( $k$ - $\epsilon$ ,  $k$ - $\omega$ ) assume the turbulent fluctuations to be essentially isotropic, whereas buoyancy always introduces stronger motions in the vertical direction. More complex closures (e.g. RSM), are much less robust, and more expensive in CPU time. This is an active research area.

## Gaps in the Assessment Bases (3)

### Fluid-Structure Interaction (CFD-FEM)

The flows in the primary circuit components of reactors are often strong enough to induce vibrations in, or damage to, confining or nearby structures, which may have consequences regarding plant safety. In the case of thermal-hydraulic issues relating to the containment, there are instances of chugging and flow-induced condensation producing jets in suppression pools in BWRs, and in large water pools for some evolutionary reactions in which the mechanical loads on submerged surfaces need to be determined and the heat transfer to the walls have to be simulated simultaneously, usually by coupling implicitly a CFD code and structure code.

The crucial issue is whether the coupling is one-way (i.e. the structural motion does not have a feed-back on the flow field) or two-way (i.e. when it does).

These days, one-way coupling is fairly straightforward, even under transient conditions. The CFD module calculates the velocity and temperature fields, and the thermal and mechanical loads are transferred via a data interface to the FEM solver for calculating the stresses.

In the case of two-way coupling, such as in vibrational analysis, the CFD and FEM computations need to be performed simultaneously. This is expensive in terms of CPU time, and will likely involve mesh reconstruction, which is also time consuming. There may also be problems in matching the CFD and FEM numerical algorithms.

In the commercial CFD world, there are now strong corporate connections between the CFD and FEM code vendors, so the technicalities of the coupling should soon be overcome.

*At this time, assessment bases for fluid-structure interaction capability are very problem-specific and need to be generalised.*

## Gaps in the Assessment Bases (4)

### Coupling of CFD code with Neutronics Codes

Precise prediction of the thermal loads to fuel rods, and of core behaviour, result from a balance between the thermal hydraulics and the neutronics. The thermal hydraulics is coupled with the neutronics through the heat release due to neutronic activity (nuclear power distribution and evolution), and the neutronics is coupled with the thermal hydraulics through the temperature (fuel and moderator), density (moderator), and the possible concentration of neutron absorber material (e.g. boron). Only the nuclear community has an interest in these topics.

The current state-of-the-art is a coupling between a sub-channel description of the thermal hydraulics and neutron diffusion at the assembly level.

The difficulty is to perform a coupled simulation, involving a CFD code adapted to the core description and a neutronics code, and to ensure consistent space and time precision of the two aspects.

Several benchmarks have been computed in the frame of OECD/NEA, including a PWR Main Steam Line Break, BWR Turbine Trip, and the VVER-1000 Coolant Transient (for which fine-mesh CFD models were used).

A concerted effort is needed to bring together all appropriate data  
to place the assessment process on a sound basis.

## Gaps in the Assessment Bases (5)

### Coupling CFD with System Codes

Performing a nuclear reactor simulation are beyond the possibilities of present hardware if a CFD code is used alone. Use of a less detailed and less demanding system analysis code to produce initial and boundary conditions for the CFD code is a practical alternative. Links have been established between major system and CFD or CFD-like codes (see right).

System code	CFD code
RELAP5	COBRA/TF
ATHLET	FLUBOX
ATHLET	CFX-4
RELAP5	CFX-4
RELAP5	FLUENT

The coupling is performed via an [Executive Program](#), which monitors the progress in each code, determines when both codes have converged, governs the information interchanges between the codes, and issues instructions to allow each code to progress to the next time step.

The first validation matrix has been set up for the RELAP5-3D/FLUENT coupled code (which was intended for application to pebble-bed modular reactors and other high-temperature gas reactor systems). The matrix involves the simulation of basic flows, such as turbulent flow in a pipe section, flow over a backward-facing step with heat transfer, flow through a pebble-bed core (porous medium approach), and even neutronic-fluid interaction in a core.

Note that it is not sufficient to validate the system and CFD codes separately: the coupled code has to be validated. This will have to progress using integral-type data from system-code benchmark exercises.

[Good progress is being made in this area.](#)

## Computing Power Limitations

### Parkinson's Law

Original version: "Work expands to fill the time available", was first articulated by Prof. C. Northcote Parkinson, and is based on a study of the British Civil Service, whose number of employees always seems to increase.

From this have arisen a number of variants.

Parkinson's Law of Data: "Data expands to fill the space available for storage".

Parkinson's Law of Bandwidth Absorption: "Network traffic expands to fill the available bandwidth".

Why not one for CFD?

Parkinson's Law of CFD could read: "CFD expectations expand to fill the available machine capacity".

In NRS applications, situations requiring analysis are often of a transient nature. CFD codes are computationally demanding, both in terms of memory usage and in the number of operations. These days, CFD simulations using 30 million nodes are common in many industrial applications.

It is evident that the pursuit of quality and trust in the application of CFD to transient NRS problems, adhering strictly to the dictates of a [Best Practice Guidelines](#) philosophy of multi-mesh simulations and higher order algorithms, will stretch available computing power to the limit for some years to come. In the mid-term, compromises will have to be made: for example, examining mesh sensitivity for a restricted part of the computational domain, or to a specific period in the entire transient.

Certainly, expanding efforts in NRS will ensure that Parkinson's Law will prevail for CFD.

## Follow-Up Activity: Special CFD Group

### Initiative

CSNI Working Group on the Analysis and Management of Accidents (WGAMA)

### Objectives

Identify generic and country-specific safety issues that need to be addressed using CFD

Identify needs and priorities for future CFD work, and set priorities for 2008-2010 and beyond

### Options to consider

Next CFD4NRS workshop in 2008

Continuous update of BPGs for NRS applications

Maintenance of web-based CFD assessment database

Database and BPGs for multi-phase applications

### Panel of Experts

Consisted of 8 members plus secretariat, representing France, Germany, S. Korea, Japan, Switzerland and US.

### Meeting

Just one meeting was held in May 2007. Prior to the meeting, a questionnaire was sent out to all members.

## Questionnaire

Country?

Safety Item (title plus short description)?

Reactor Type?

Does issue effect one plant or many?

Is it a licensing issue?

Is it an operational issue?

Is it a performance enhancement issue?

Is it a plant life-time extension issue?

Is it an issue of public concern?

Have there been incidents already? When? Degree of severity?

Does resolution of the issue influence plant shut-down?

What is the status of in-depth analyses to date?

In what way could CFD bring real benefits or new insights?

What is the likelihood of success if CFD studies were made?

What is the time frame under which they could be undertaken?

Is this a matter of generic interest to the nuclear community?

What priority (H/M/L) would your country give to resolving this issue?

Which other countries would benefit from resolution of this issue?

Do you regard CFD to already be mature enough to resolve this issue?

If yes, how do you see that the OECD/CSNI/GAMA can help here? Benchmarking activity? International forum?

If no, what specific modelling areas require further development? Estimated time to trustworthiness?

## Meeting (1)

### 1. Core Group

Consensus of opinion that there should be some, scaled-down continuation of the work of the CFD Writing Groups

Most favoured solution was to form a small **CFD Core Group**, consisting of the 3 chairmen of the existing WGs, NEA secretariat and NEA webmaster

Tasks to be performed by core group

- set up and maintain web-based, continuing CFD activity on NEA web site
- to act as a central organisation for any future workshops in the CFD4NRS series...  
with the aim of providing a forum for the application/validation/extension of CFD in NRS

### 2. Safety Issues Needing CFD

Each participant described safety issues relevant to his/her nuclear power programme for which CFD could be expected to bring real benefits, as itemised on the questionnaire

Fairly clear categorisation into items of **generic interest**, for which an OECD/NEA benchmarking exercise would be useful, and those items for which there was **country-specific interest**, for which internal benchmarking would be more appropriate (though passive exchange of information desirable)

### 3. Prioritisation of Safety Issues

Certain points of common interest emerged, so it was decided to prioritise these after the meeting

## Meeting (2)

### 4. External Group Participation

It was decided to widen the group representation in the task of prioritisation of safety issues. Consequently, the questionnaire sent to representatives of Belgium, Canada, Czech Republic, Finland, Italy, Netherlands, Slovenia, Spain

### 5. Cross-Cutting Issues

DNB: also of interest to CSNI fuel safety group and the Nuclear Safety Committee

CHF: ambitious for CFD, but of potential interest to industry and CSNI fuel safety group

### 6. Uncertainties

It was recognised that, due to CPU overheads, proper uncertainty qualification analysis could not be performed using CFD, as was common with system codes.

Generally, for each system transient, 50-100 computations are carried out for an uncertainty analysis

This is not possible for CFD, though application of BPGs goes some way: e.g. mesh-independency, sensitivity to input parameters over part of the transient (ECORA). More CPUs (parallel processing) will improve the situation

## Post-Meeting (1)

### 7. Overall Priority Ranking (Single-Phase)

Topic (single-phase)	Score/36	Generic Interest
PTS	31	<b>HIGH</b>
Hydrogen mixing and combustion in containments	31	
Flows in complex geometries*	29	
Boron dilution	28	
Sump strainer clogging	26	
Aerosol deposition in containments	26	
Thermal fatigue	23	<b>MEDIUM</b>
MSLB (leading to asymmetric flow)	22	
Hot-leg heterogeneities	21	
HTGR lower plenum mixing	16	
HTGR core heat transfer	15	
HTGR reactor cavity cooling heat transfer	13	<b>LOW</b>
GCR/VHTR heat transfer issues	12	
Flow behind blockages in LMFRs	9	
Flow-induced vibrations in LMFRs	8	
Core barrel vibration in APWR	6	

## Post-Meeting (2)

### 6. Overall Priority Ranking ( Multi-Phase)

Topic (multi-phase)	Score/36	
Reflooding/following LB-LOCA, including UPI and EPR	28	<b>HIGH</b>
PTS	27	
CHF	26	
Condensation-induced water hammer	26	
Sub-cooled boiling in PWRs	23	<b>MEDIUM</b>
Steam condensation in pools	19	
Induced break	16	
Gas entrainment in LMFRs	9	<b>LOW</b>
Special issues for CANDU reactors	3	

## High Priority Items (Single-Phase 1)

### 1. PTS

Comprehensive study in 1980s: NUREG/CR-5677

Renewed interest from E. Europe: VVERs have ECC injection from below (submerged jet) in cold-leg

Also, submerged side injection in some German PWRs

French PWRs have injection from top, and two-phase PTS of more interest

No lack of validation data: UPTF, ROCOM, FORTUM..., but needs to be scrutinised to determine whether a benchmark can be defined unambiguously

### 2. Hydrogen Distribution in Containments

Large containment experiments: MISTRA, TOSQAN, ThAI already subject of benchmarking: ISP-47

Experiments in OECD/SETH series in PANDA (formation of stratification): benchmarking in ECORA

New OECD/SETH-2 experiments underway (destruction of stratification)

HYSAFE 6<sup>th</sup> EU FWP addresses general hydrogen safety issues... relevant?

## High Priority Items (Single-Phase 2)

### 3. Flow in Complex Geometries

Addressed in 5<sup>th</sup> EU FWP FLOWMIX-R

No lack of validation data: UPTF TRAM C3, ROCOM,...

### 4. Boron Dilution

Addressed in ISP-43, based on University of Maryland Experiments, EUBORA

Also part of general flow mixing: e.g. FLOWMIX-R

### 5. Aerosol Distribution in Containments

Definite lack of suitable validation data here

EU 5<sup>th</sup> FWP PHEBEN, based on CEA PHEBUS tests, produced integral data only, limited for CFD

May need to go outside nuclear power area for better data... needs exploring

## High Priority Items (Multi-Phase)

### 1. PTS

Addressed in 6<sup>th</sup> EU FWP NURESIM, and any follow-up project

No lack of validation data: HYBISCUS, UPTF-TRAM C1, COSI, ROSA,...

Forthcoming TOPFLOW-PTS experiment at FZD will provide high quality data (but restricted!)

### 2. LB-LOCA

Remains the classical DBA: system analysis capability is mature. Need to focus on some 3-D aspects for CFD to be useful

### 3. CHF

Ambitious target for CFD. Subject of 6<sup>th</sup> EU FWP NURESIM, so apparently no lack of interest.

Influence of spacers paramount (proprietary information), though some scope for benchmark based on generic spacer design in KAERI experiments

### 4. Condensation-Induced Water Hammer

Addressed in EU 5<sup>th</sup> FWP WAHALoads. Sonic event, not suitable for Courant-restricted system codes

## Outcome

### Proposal

Set up a [CFD Core Group](#) to oversee the following tasks:

1. Construct a [web-based centre of expertise on the application of CFD to NRS](#), to consolidate, update and extend:
  - Best Practice Guidelines for the Use of CFD in NRS Applications
  - Assessment of CFD Codes for NRS Problems
  - Extension to Application to Two-Phase NRS Problems
2. Provide the [central organising committee](#) for the XCFD4NRS Workshop, and future workshops in the series
3. Evaluate the [potential for benchmarking activities](#) based on the priority ranking established by the PIRT

### Status

Meeting of Special CFD Group was held in May 2008.

1. Basic layout of the WG2 website begun in July 2008.
2. Final preparations made for the XCFD4NRS Workshop in Grenoble, 10-12 Sept. 2008.
3. Benchmarking activities to be discussed at the OECD/NEA WGAMA meeting in Sept. 2008

## Main webpage for WG2

Listed are the main chapters of the final document

NEA/CSNI/R(2007)13

Each item is an internal link to the detailed information.

For example, clicking here  opens the page to the Executive Summary...

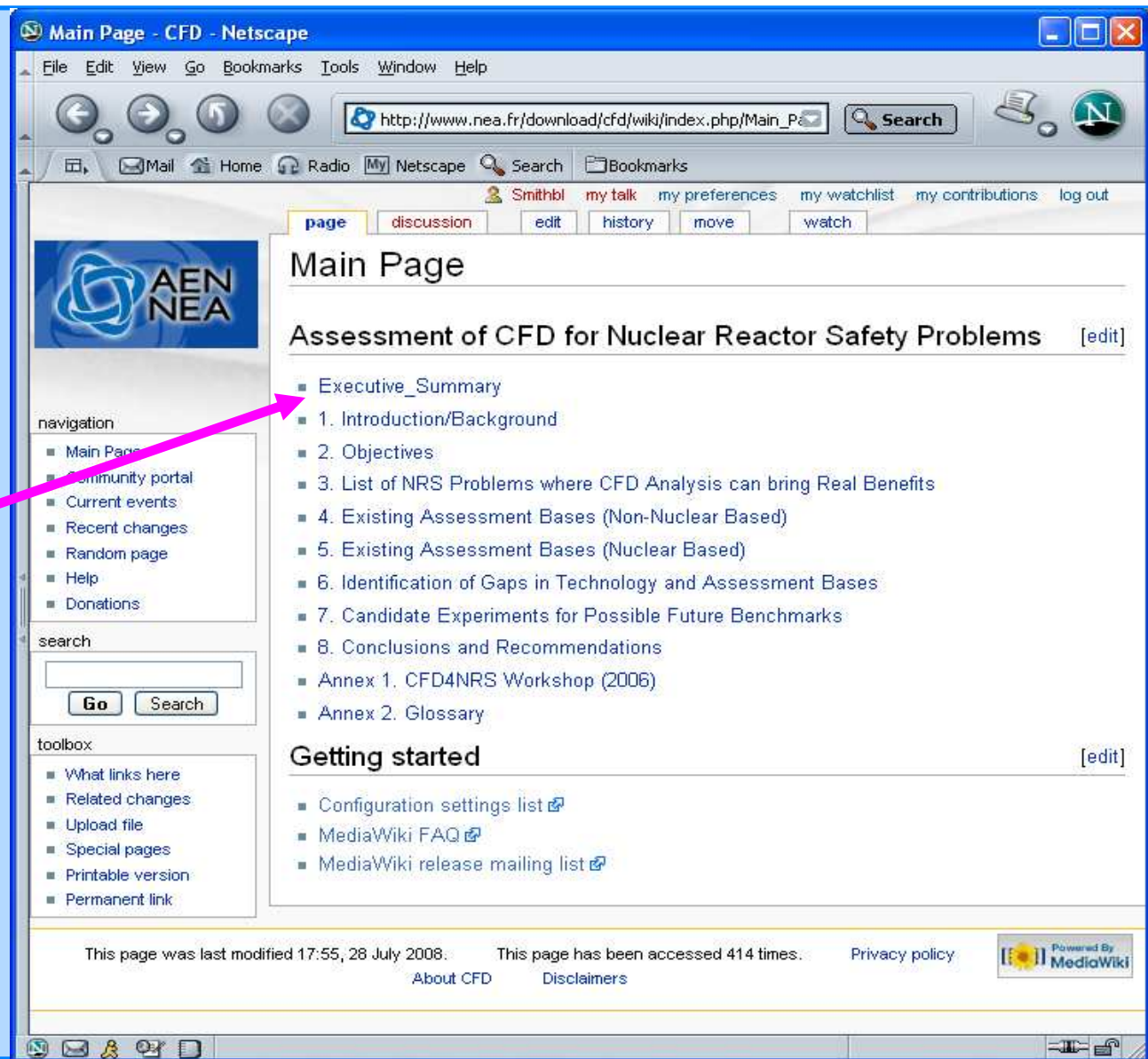

**Main Page - CFD - Netscape**

File Edit View Go Bookmarks Tools Window Help

http://www.nea.fr/download/cfd/wiki/index.php/Main\_Page Search

Smithbl my talk my preferences my watchlist my contributions log out

page discussion edit history move watch

**Main Page**

**Assessment of CFD for Nuclear Reactor Safety Problems** [edit]

- Executive\_Summary
- 1. Introduction/Background
- 2. Objectives
- 3. List of NRS Problems where CFD Analysis can bring Real Benefits
- 4. Existing Assessment Bases (Non-Nuclear Based)
- 5. Existing Assessment Bases (Nuclear Based)
- 6. Identification of Gaps in Technology and Assessment Bases
- 7. Candidate Experiments for Possible Future Benchmarks
- 8. Conclusions and Recommendations
- Annex 1. CFD4NRS Workshop (2006)
- Annex 2. Glossary

**Getting started** [edit]

- Configuration settings list
- MediaWiki FAQ
- MediaWiki release mailing list

This page was last modified 17:55, 28 July 2008. This page has been accessed 414 times. Privacy policy About CFD Disclaimers

Powered By MediaWiki

## Main webpage for WG2

The page contains the entire executive summary, as it appears in the original document.

The scroll bar on the right is active, as is the Browser's "find" facility

Return to the main page can either be at the Browser level

or via the "navigation bar" (to be developed)

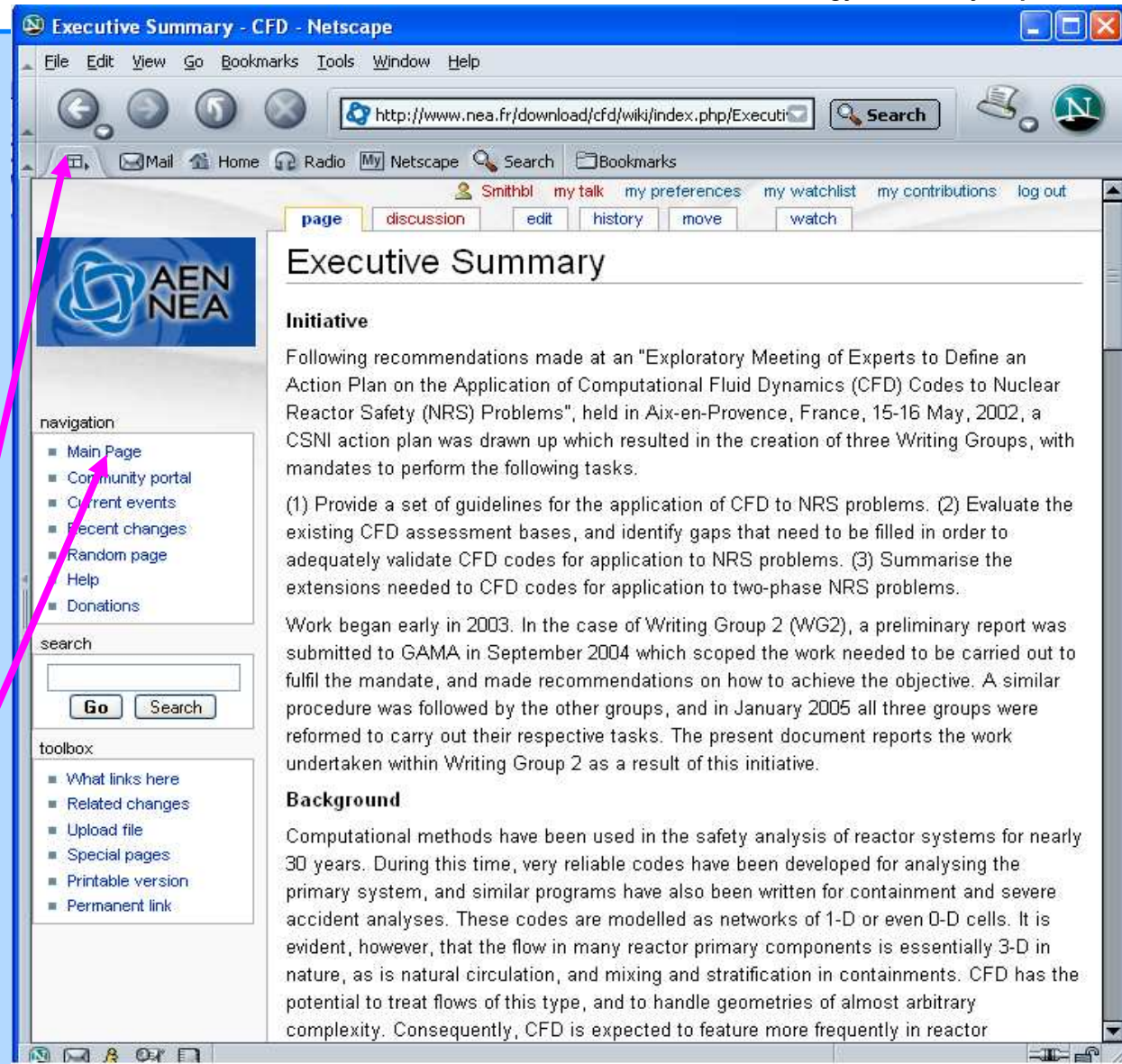

**Executive Summary**

**Initiative**

Following recommendations made at an "Exploratory Meeting of Experts to Define an Action Plan on the Application of Computational Fluid Dynamics (CFD) Codes to Nuclear Reactor Safety (NRS) Problems", held in Aix-en-Provence, France, 15-16 May, 2002, a CSNI action plan was drawn up which resulted in the creation of three Writing Groups, with mandates to perform the following tasks.

(1) Provide a set of guidelines for the application of CFD to NRS problems. (2) Evaluate the existing CFD assessment bases, and identify gaps that need to be filled in order to adequately validate CFD codes for application to NRS problems. (3) Summarise the extensions needed to CFD codes for application to two-phase NRS problems.

Work began early in 2003. In the case of Writing Group 2 (WG2), a preliminary report was submitted to GAMA in September 2004 which scoped the work needed to be carried out to fulfil the mandate, and made recommendations on how to achieve the objective. A similar procedure was followed by the other groups, and in January 2005 all three groups were reformed to carry out their respective tasks. The present document reports the work undertaken within Writing Group 2 as a result of this initiative.

**Background**

Computational methods have been used in the safety analysis of reactor systems for nearly 30 years. During this time, very reliable codes have been developed for analysing the primary system, and similar programs have also been written for containment and severe accident analyses. These codes are modelled as networks of 1-D or even 0-D cells. It is evident, however, that the flow in many reactor primary components is essentially 3-D in nature, as is natural circulation, and mixing and stratification in containments. CFD has the potential to treat flows of this type, and to handle geometries of almost arbitrary complexity. Consequently, CFD is expected to feature more frequently in reactor

## Main webpage for WG2

Larger chapters are subdivided...

...the page layout being constructed similarly, the sub-chapters being active links to the detailed information

Further subdivisions have been installed, as necessary

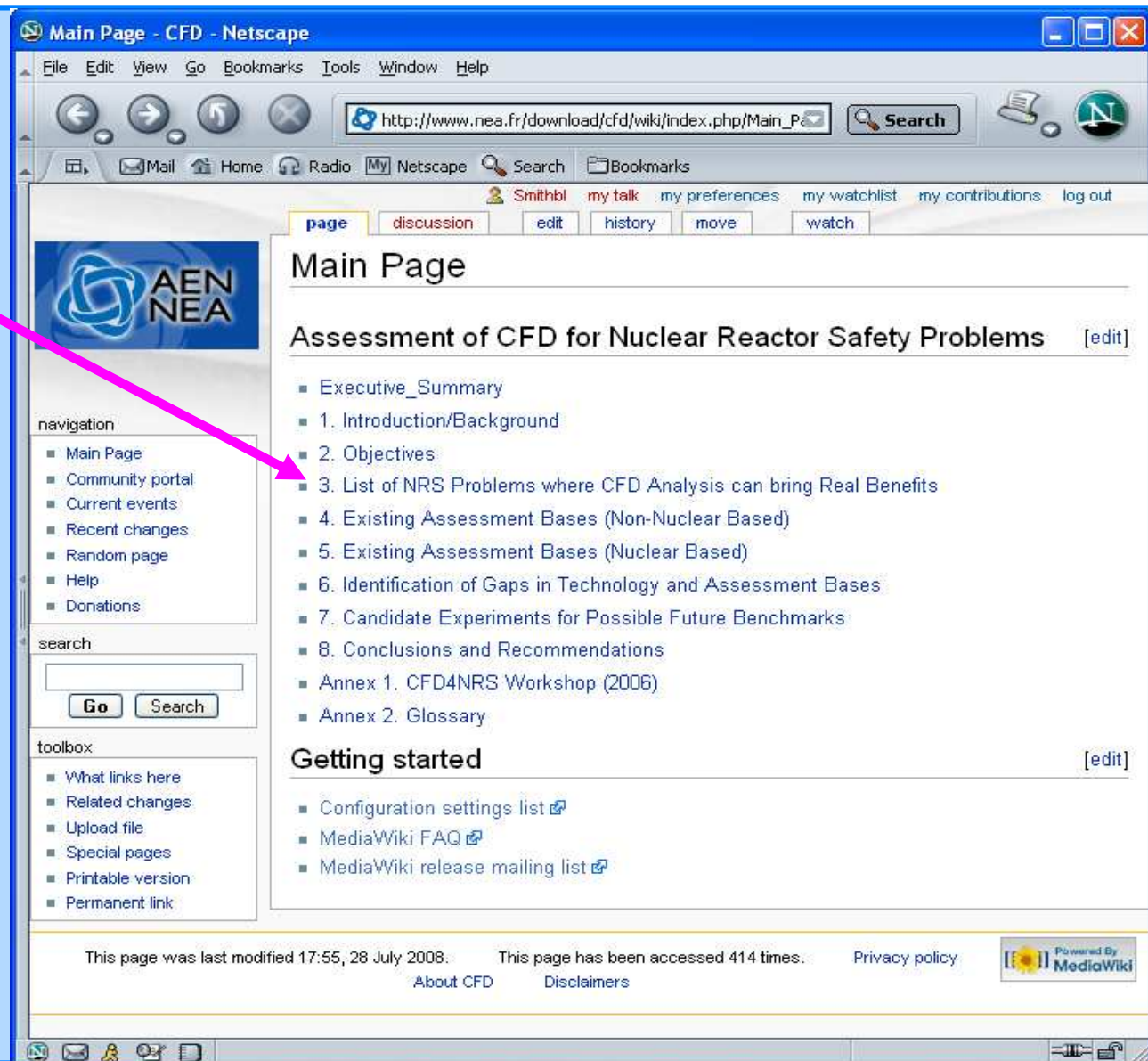

**Main Page**

**Assessment of CFD for Nuclear Reactor Safety Problems** [edit]

- Executive\_Summary
- 1. Introduction/Background
- 2. Objectives
- 3. List of NRS Problems where CFD Analysis can bring Real Benefits
- 4. Existing Assessment Bases (Non-Nuclear Based)
- 5. Existing Assessment Bases (Nuclear Based)
- 6. Identification of Gaps in Technology and Assessment Bases
- 7. Candidate Experiments for Possible Future Benchmarks
- 8. Conclusions and Recommendations
- Annex 1. CFD4NRS Workshop (2006)
- Annex 2. Glossary

**Getting started** [edit]

- Configuration settings list
- MediaWiki FAQ
- MediaWiki release mailing list

This page was last modified 17:55, 28 July 2008. This page has been accessed 414 times. Privacy policy

About CFD Disclaimers

Powered By MediaWiki

## Main webpage for WG2

As an example, clicking on  
“Boron Dilution”...

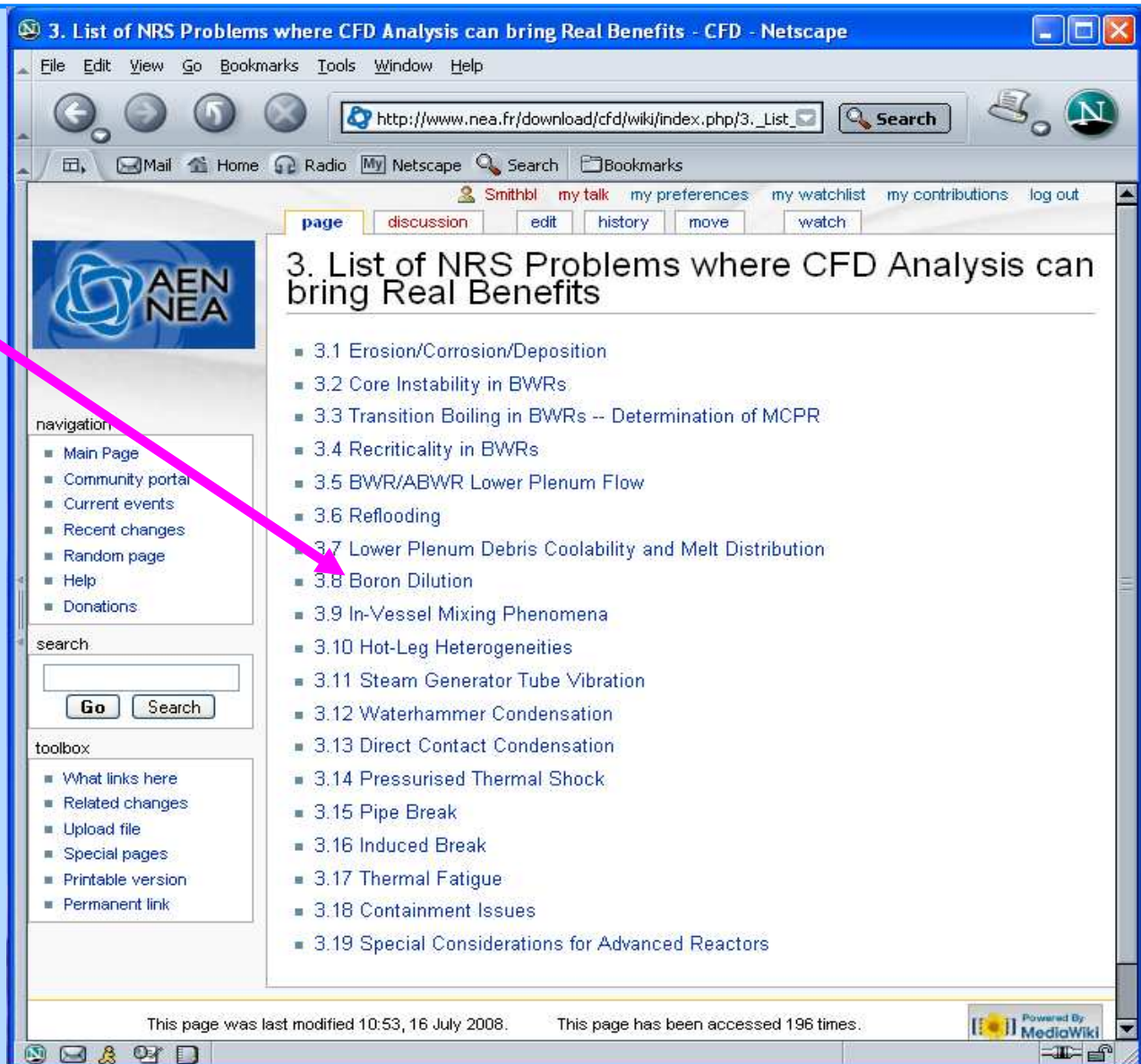

3. List of NRS Problems where CFD Analysis can bring Real Benefits - CFD - Netscape

File Edit View Go Bookmarks Tools Window Help

http://www.nea.fr/download/cfd/wiki/index.php/3.\_List\_ Search

Smithbl my talk my preferences my watchlist my contributions log out

page discussion edit history move watch

 AEN  
NEA

### 3. List of NRS Problems where CFD Analysis can bring Real Benefits

- 3.1 Erosion/Corrosion/Deposition
- 3.2 Core Instability in BWRs
- 3.3 Transition Boiling in BWRs -- Determination of MCPR
- 3.4 Recriticality in BWRs
- 3.5 BWR/ABWR Lower Plenum Flow
- 3.6 Reflooding
- 3.7 Lower Plenum Debris Coolability and Melt Distribution
- 3.8 Boron Dilution
- 3.9 In-Vessel Mixing Phenomena
- 3.10 Hot-Leg Heterogeneities
- 3.11 Steam Generator Tube Vibration
- 3.12 Waterhammer Condensation
- 3.13 Direct Contact Condensation
- 3.14 Pressurised Thermal Shock
- 3.15 Pipe Break
- 3.16 Induced Break
- 3.17 Thermal Fatigue
- 3.18 Containment Issues
- 3.19 Special Considerations for Advanced Reactors

navigation

- Main Page
- Community portal
- Current events
- Recent changes
- Random page
- Help
- Donations

search

Go Search

toolbox

- What links here
- Related changes
- Upload file
- Special pages
- Printable version
- Permanent link

This page was last modified 10:53, 16 July 2008. This page has been accessed 196 times.

Powered By MediaWiki

## Main webpage for WG2

...links to the page containing  
the detailed information

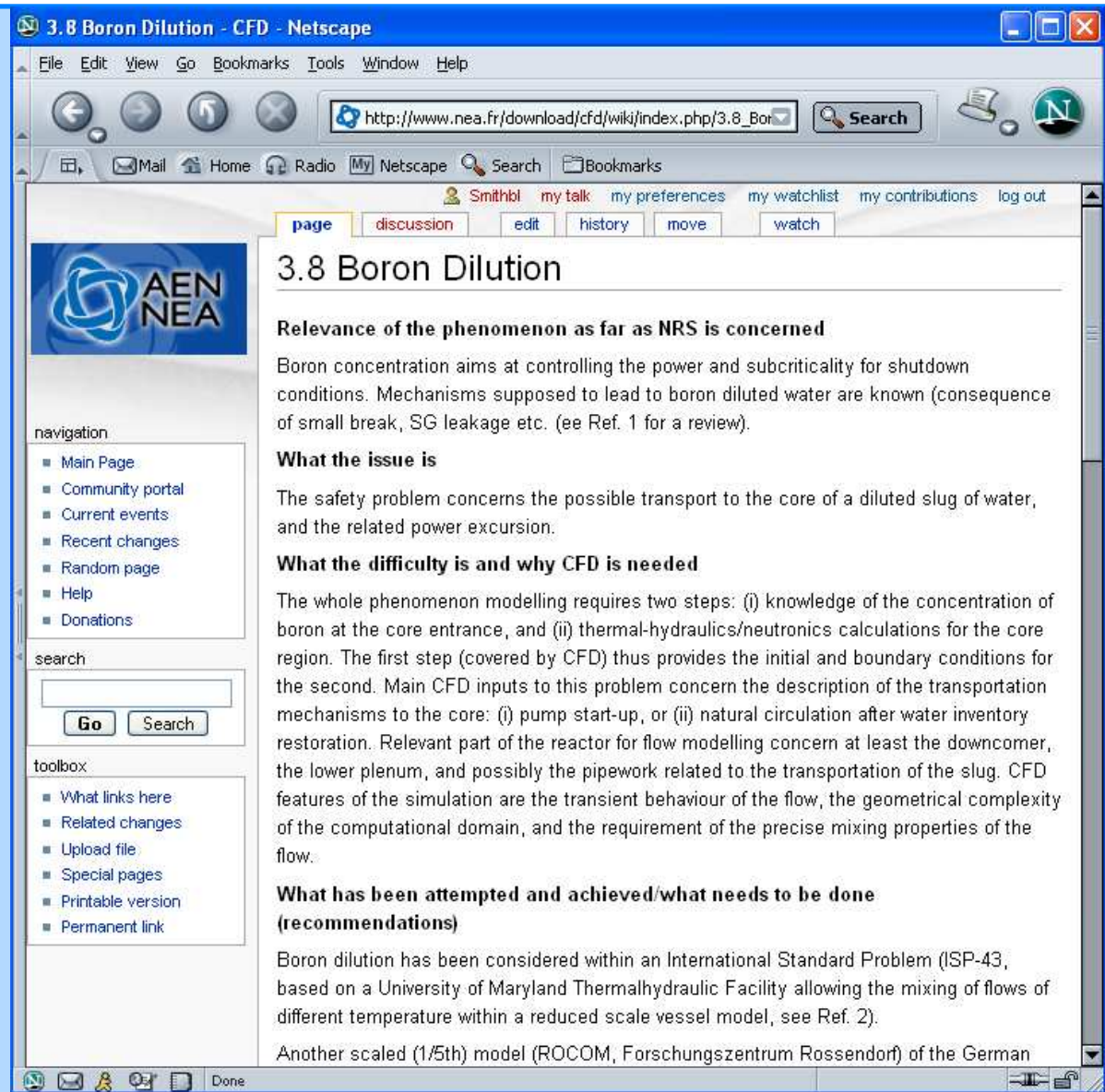

The screenshot shows a Netscape browser window with the title "3.8 Boron Dilution - CFD - Netscape". The address bar contains the URL "http://www.nea.fr/download/cfd/wiki/index.php/3.8\_Bor". The page content includes a navigation menu on the left, a search box, and a main text area with several sections:

- 3.8 Boron Dilution**
- Relevance of the phenomenon as far as NRS is concerned**  
Boron concentration aims at controlling the power and subcriticality for shutdown conditions. Mechanisms supposed to lead to boron diluted water are known (consequence of small break, SG leakage etc. (see Ref. 1 for a review).
- What the issue is**  
The safety problem concerns the possible transport to the core of a diluted slug of water, and the related power excursion.
- What the difficulty is and why CFD is needed**  
The whole phenomenon modelling requires two steps: (i) knowledge of the concentration of boron at the core entrance, and (ii) thermal-hydraulics/neutronics calculations for the core region. The first step (covered by CFD) thus provides the initial and boundary conditions for the second. Main CFD inputs to this problem concern the description of the transportation mechanisms to the core: (i) pump start-up, or (ii) natural circulation after water inventory restoration. Relevant part of the reactor for flow modelling concern at least the downcomer, the lower plenum, and possibly the pipework related to the transportation of the slug. CFD features of the simulation are the transient behaviour of the flow, the geometrical complexity of the computational domain, and the requirement of the precise mixing properties of the flow.
- What has been attempted and achieved/what needs to be done (recommendations)**  
Boron dilution has been considered within an International Standard Problem (ISP-43, based on a University of Maryland Thermalhydraulic Facility allowing the mixing of flows of different temperature within a reduced scale vessel model, see Ref. 2).  
Another scaled (1/5th) model (ROCOM, Forschungszentrum Rossendorf) of the German

## Main webpage for WG2

The “search” facility...

...gives ‘hits’ at the level of the page titles as well as the text within the pages

The titles are “active” within the search operation, with links to the relevant sections

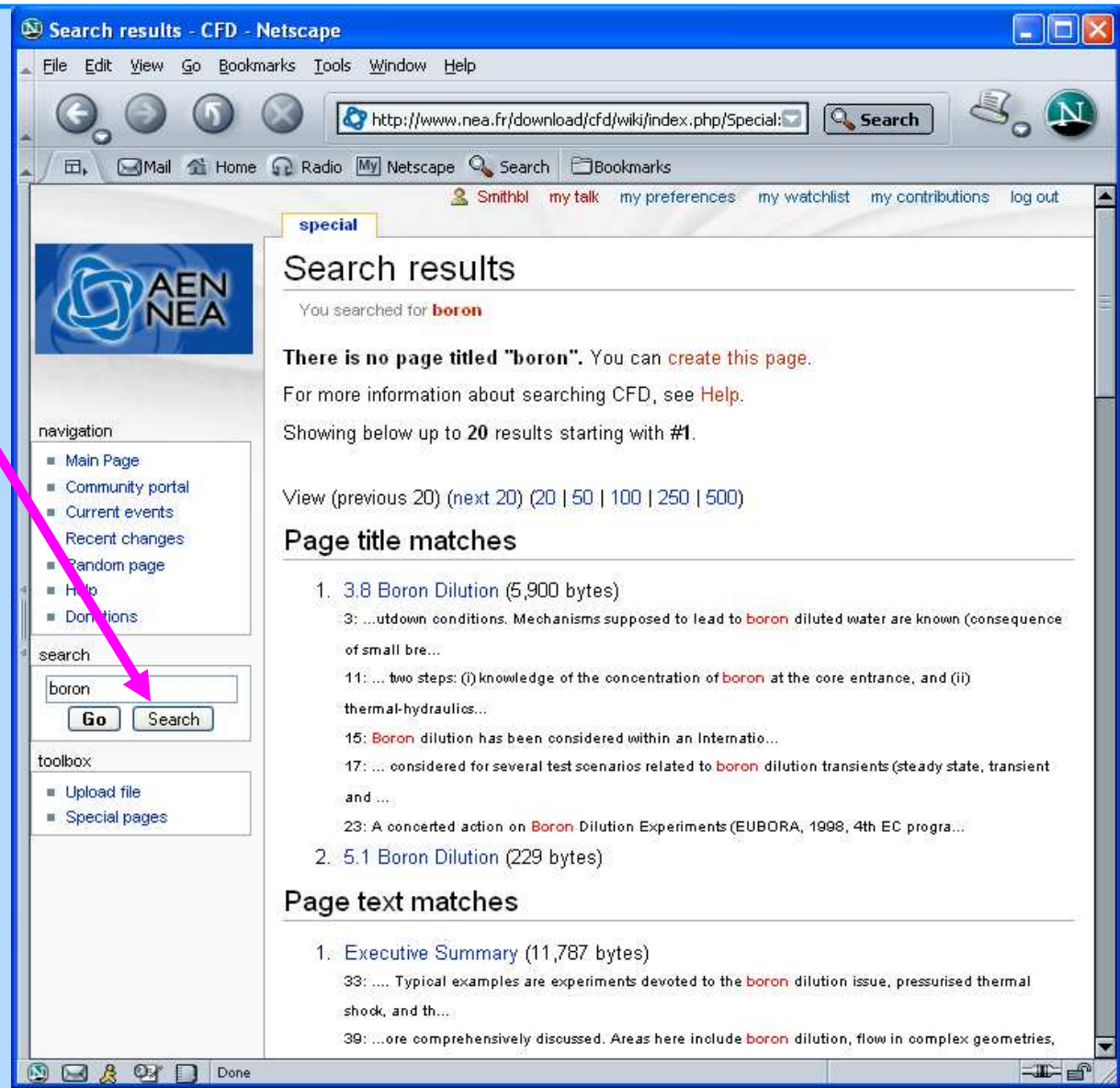

Search results - CFD - Netscape

File Edit View Go Bookmarks Tools Window Help

http://www.nea.fr/download/cfd/wiki/index.php/Special: Search

Smithbl my talk my preferences my watchlist my contributions log out

special

**Search results**

You searched for **boron**

**There is no page titled "boron".** You can [create this page](#).

For more information about searching CFD, see [Help](#).

Showing below up to **20** results starting with **#1**.

View (previous 20) (next 20) (20 | 50 | 100 | 250 | 500)

**Page title matches**

- 3.8 Boron Dilution (5,900 bytes)
  - 3: ...utdown conditions. Mechanisms supposed to lead to **boron** diluted water are known (consequence of small bre...
  - 11: ... two steps: (i) knowledge of the concentration of **boron** at the core entrance, and (ii) thermal-hydraulics...
  - 15: **Boron** dilution has been considered within an Internatio...
  - 17: ... considered for several test scenarios related to **boron** dilution transients (steady state, transient and ...
  - 23: A concerted action on **Boron** Dilution Experiments (EUBORA, 1998, 4th EC progra...
- 5.1 Boron Dilution (229 bytes)

**Page text matches**

- Executive Summary (11,787 bytes)
  - 33: .... Typical examples are experiments devoted to the **boron** dilution issue, pressurised thermal shock, and th...
  - 39: ...ore comprehensively discussed. Areas here include **boron** dilution, flow in complex geometries,

navigation

- Main Page
- Community portal
- Current events
- Recent changes
- Random page
- Help
- Donations

search

boron

Go Search

toolbox

- Upload file
- Special pages

Done

## Main webpage for WG2

The starting point for the information on the webpage is the WG2 final document

NEA/CSNI/R(2007)13

But the intention is to have regular updates, coordinated by the CFD Core Group

There will be [open access to the website for all OECD member countries](#), but with a registration procedure

Information on access to the website will be passed out via member country's representative on the CSNI/WGAMA committee

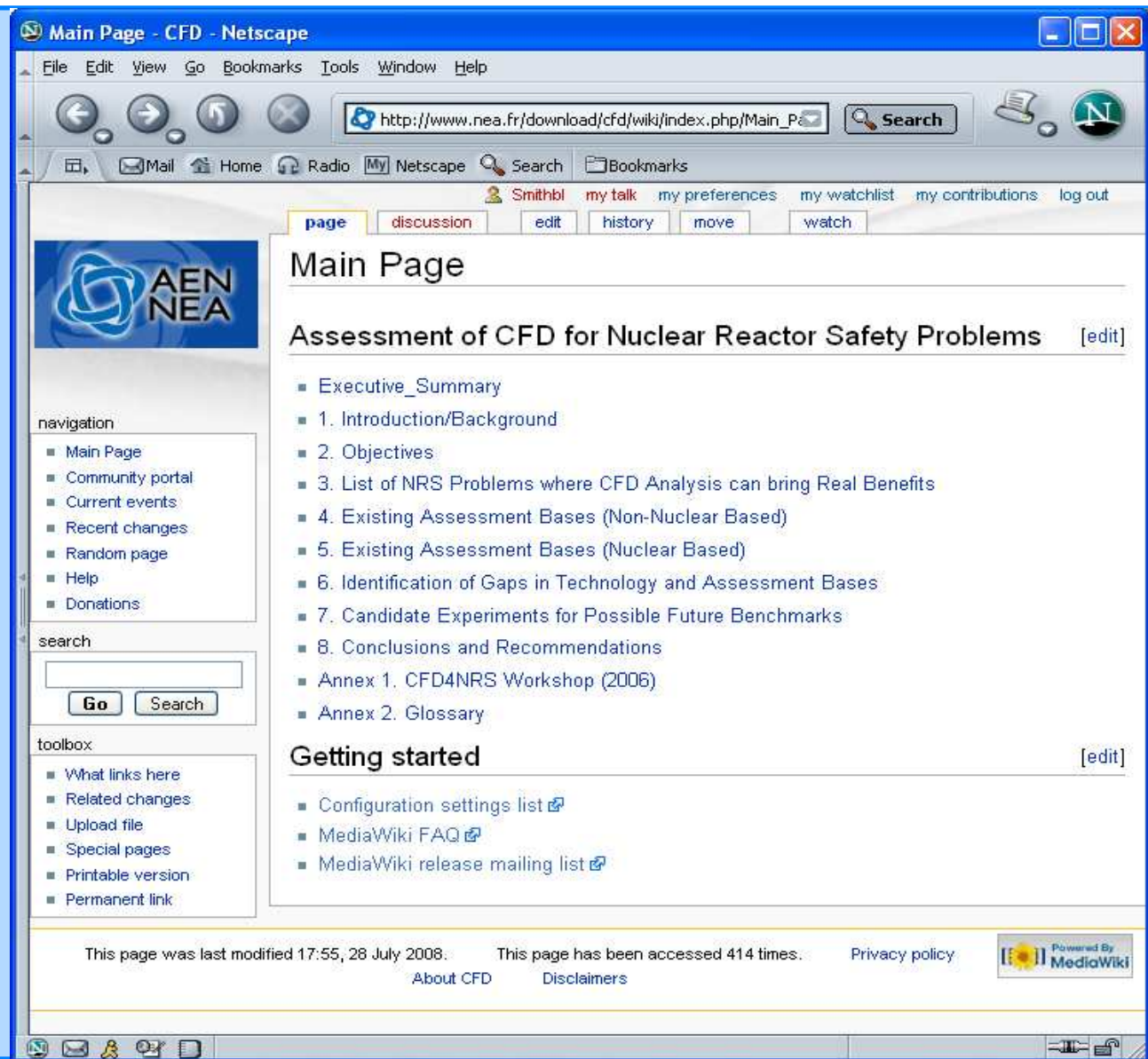

**Main Page - CFD - Netscape**

File Edit View Go Bookmarks Tools Window Help

http://www.nea.fr/download/cfd/wiki/index.php/Main\_Page Search

Smithbl my talk my preferences my watchlist my contributions log out

page discussion edit history move watch

**Main Page**

**Assessment of CFD for Nuclear Reactor Safety Problems** [edit]

- Executive\_Summary
- 1. Introduction/Background
- 2. Objectives
- 3. List of NRS Problems where CFD Analysis can bring Real Benefits
- 4. Existing Assessment Bases (Non-Nuclear Based)
- 5. Existing Assessment Bases (Nuclear Based)
- 6. Identification of Gaps in Technology and Assessment Bases
- 7. Candidate Experiments for Possible Future Benchmarks
- 8. Conclusions and Recommendations
- Annex 1. CFD4NRS Workshop (2006)
- Annex 2. Glossary

**Getting started** [edit]

- Configuration settings list
- MediaWiki FAQ
- MediaWiki release mailing list

navigation

- Main Page
- Community portal
- Current events
- Recent changes
- Random page
- Help
- Donations

search

Go Search

toolbox

- What links here
- Related changes
- Upload file
- Special pages
- Printable version
- Permanent link

This page was last modified 17:55, 28 July 2008. This page has been accessed 414 times. Privacy policy About CFD Disclaimers

Powered By MediaWiki

## Summary

### Origins of the OECD/NEA Writing Groups:

WG1: Best Practice Guidelines for CFD in NRS Applications

WG2: Single-Phase Assessment Bases

WG3: Extension of CFD for Two-Phase NRS Applications

### Contents of WG2 Document

- List of NRS problems for which CFD analysis can bring real benefits  
(boron dilution, thermal fatigue, heterogeneous flow, stratification, mixing, etc.)
- Description of existing non-nuclear based databases  
(ERCOFTAC, QNET-CFD, MARNET, FLOWNET, INPARC Alliance, AIAA, Vattenfall)
- Description of existing (nuclear based) databases  
(boron dilution, PTS, thermal fatigue, Euratom FWPs, etc.)
- Identification of gaps in technology and assessment bases  
(turbulence models, stratification, buoyancy, coupling with neutronics/FEM/system codes, CPU limitations)
- List of candidate experiments for possible future benchmarks  
(ROCOM, HAWAC, T-junction expts., MATIS-H, TOSQAN, MISTRA, PANDA, RUT, etc.)

### Follow-Up Activities

- CFD Special Group to prioritise safety issues of generic interest – reported back to CSNI/WGAMA
- Formation of CFD Core Group to oversee: (1) web-based versions of WG documents; (2) organise XCFD4NRS and future workshops; (3) set up benchmarking activities in NRS



***THE END***